



Australian Government

**National Measurement
Institute**

Bradfield Road, West Lindfield NSW 2070

Supplementary Certificate of Approval

NMI S558

Issued by the Chief Metrologist under Regulation 60
of the
National Measurement Regulations 1999

This is to certify that an approval for use for trade has been granted in respect of the instruments herein described.

Newtech Model ATH8C-C3-1.5t-4WB Load Cell

submitted by @Weigh Pty Ltd
Unit 31, 102 Keys Road
Moorabbin VIC 3189

NOTE: This Certificate relates to the suitability of the pattern of the instrument for use for trade only in respect of its metrological characteristics. This Certificate does not constitute or imply any guarantee of compliance by the manufacturer or any other person with any requirements regarding safety.

This approval has been granted with reference to document NMI R 60, *Metrological Regulation for Load Cells*, dated July 2004.

This approval becomes subject to review on **1/3/17**, and then every 5 years thereafter.

DOCUMENT HISTORY

Rev	Reason/Details	Date
0	Pattern and variants 1 & 2 approved – certificate issued	24/02/12

CONDITIONS OF APPROVAL

General

Instruments purporting to comply with this approval shall be marked with approval number 'NMI S558' and only by persons authorised by the submittor.

Instruments incorporating a component purporting to comply with this approval shall be marked 'NMI S558' in addition to the approval number of the instrument, and only by persons authorised by the submittor.

It is the submittor's responsibility to ensure that all instruments marked with this approval number are constructed as described in the documentation lodged with the National Measurement Institute (NMI) and with the relevant Certificate of Approval and Technical Schedule. Failure to comply with this Condition may attract penalties under Section 19B of the National Measurement Act and may result in cancellation or withdrawal of the approval, in accordance with document NMI P 106.

The values of the performance criteria (maximum number of scale intervals etc.) applicable to an instrument incorporating the pattern approved herein shall be within the limits specified herein and in any approval documentation for the other components.

Signed by a person authorised by the Chief Metrologist to exercise his powers under Regulation 60 of the *National Measurement Regulations 1999*.

A handwritten signature in black ink, consisting of a series of loops and flourishes, positioned to the right of the signature text.

TECHNICAL SCHEDULE No S558

1. Description of Pattern **approved on 24/02/12**

A Newtech model ATH8C-C3-1.5t-4WB load cell of 1500 kg maximum capacity (Figure 1 and Table 1). May also be known as a ZEMIC load cells of the same model.

1.1 Method of Mounting

Mounting is to be in accordance with the manufacturer's instructions and as shown in Figure 1b.

1.2 Markings

Each load cell is marked with the following:

Manufacturer's mark, or name written in full
Model number
Maximum capacity, E_{max} kg (or t)
Serial number
Pattern approval mark	NMI No S558

1.3 Table of Specifications

Specifications for the pattern are given in Table 1.

2. Description of Variant 1 **approved on 24/02/12**

Certain other models of the Newtech ATH8C-C3 series (or ZEMIC ATH8C C3 series) and with capacities and characteristics as listed in Table 1.

3. Description of Variant 2 **approved on 24/02/12**

Certain models of the Newtech ATH8C-C5 series (or ZEMIC ATH8C C5 series) and with capacities and characteristics as listed in Table 2.

TABLE 1

Type: ATH8C-C3-#t-4WB series as listed below, where # in the model number represents the capacity (E_{max}) in tonnes, e.g. the pattern model ATH8C-C3-1.5t-4WB is of 1.5 t (1500 kg) capacity.

Model number	#=0.5t	#=1.0t	#=1.5t	#=2.0t	#=5t
E_{max} (kg)	500	1000	1500	2000	5000
Class	C3	C3	C3	C3	C3
nLC	3000	3000	3000	3000	3000
V_{min} (kg)	0.05	0.15	0.15	0.2	0.5
DR (kg)	0.05	0.11	0.15	0.2	0.5
mV/V	3	3	3	3	3
Input imp. ohms	350	350	350	350	350
Supply voltage (V)	15	15	15	15	15
Cable length (m)	4	4	4	4	4
Number of leads (plus shield)	4	4	4	4	4

TABLE 2

Type: ATH8C-C5-#t-4WB series as listed below, where # in the model number represents the capacity (E_{max}) in tonnes, e.g. the pattern model ATH8C-C5-1.5t-4WB is of 1.5 t (1500 kg) capacity.

Model number	#=1.0t	#=1.5t	#=2.0t	#=5t
E_{max} (kg)	1000	1500	2000	5000
Class	C5	C5	C5	C5
nLC	5000	5000	5000	5000
V_{min} (kg)	0.05	0.075	0.1	0.278
DR (kg)	0.1	0.15	0.2	0.5
mV/V	3	3	3	3
Input imp. ohms	350	350	350	350
Supply voltage (V)	5-12	5-12	5-12	5-12
Cable length (m)	4	4	4	4
Number of leads (plus shield)	4	4	4	4

Where:	E_{max}	=	Maximum capacity
	nLC	=	Maximum number of verification intervals
	V_{min}	=	Minimum value of verification interval
	DR	=	Minimum dead load output return value
	mV/V	=	Output rating (nominal)
	Input imp.	=	Input impedance (nominal)
	Voltage	=	Maximum supply voltage (DC/AC)

FIGURE S558 – 1



(a) Newtech Model ATH8C-C3-1.5t-4WB Load Cell

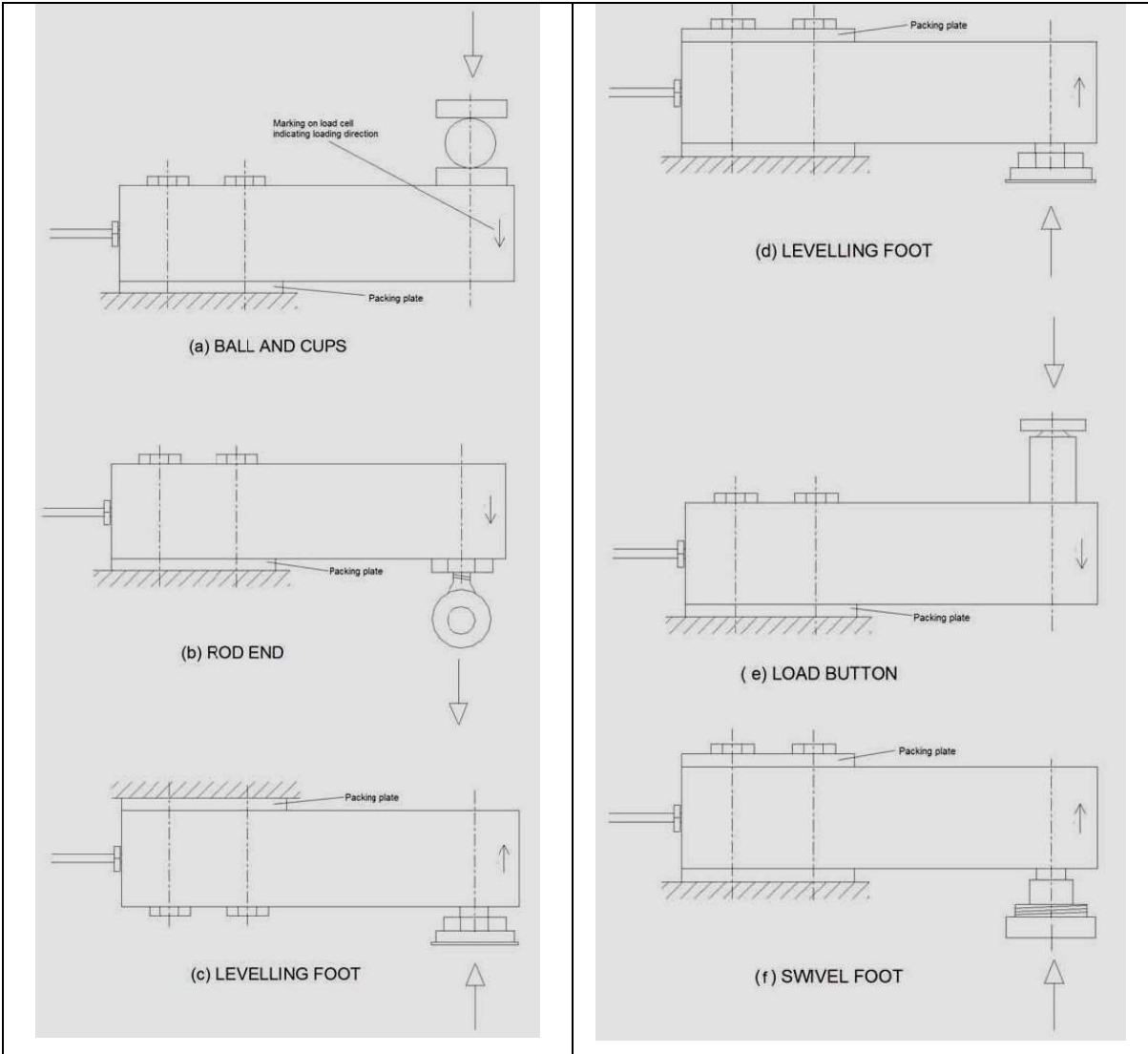

(b) Mounting Arrangements