



Australian Government
**National Measurement
Institute**

Bradfield Road, West Lindfield NSW 2070

Notification of Change
Supplementary Certificate of Approval No S509
Change No 1

Issued by the Chief Metrologist under Regulation 60
of the
National Measurement Regulations 1999

The following changes are made to the approval documentation for the
Coles Express Model ST2 Control System for Fuel Dispensers for Motor
Vehicles

submitted by WorkVentures Ltd
 (trading as Sydney ITeC Repair Centre)
 Unit A1, 200 Coward Street
 MASCOT NSW 2020.

A. In Supplementary Certificate of Approval No S509 dated
27 October 2008, the FILING ADVICE should be amended by adding
the following:

 “Notification of Change No 1 dated 16 July 2009”

B. In Technical Schedule No S509 dated 30 January 2008, clause
1.2 System Description item (ii) Flowmeter Controller, should be
amended by changing the reference to the printer (and adding a
footnote) as shown below:

- “A CBM model 1000 receipt printer **or equivalent (*)**... Figure 3.

(*) **“Equivalent” is defined to mean other proprietary
equipment of the same or better specifications requiring no
changes to software for satisfactory operation of the
complete system including all checking facilities.”**

Signed by a person authorised by the Chief Metrologist
to exercise his powers under Regulation 60 of the
National Measurement Regulations 1999.

A handwritten signature in black ink, consisting of a series of loops and a long horizontal stroke at the bottom.



Australian Government
**National Measurement
Institute**

Bradfield Road, West Lindfield NSW 2070

Supplementary Certificate of Approval
No S509

Issued by the Chief Metrologist under Regulation 60
of the
National Measurement Regulations 1999

This is to certify that an approval for use for trade has been granted in respect of the

Coles Express Model ST2 Control System for Fuel Dispensers for Motor Vehicles

submitted by WorkVentures Ltd
 (trading as Sydney ITeC Repair Centre)
 Unit A1, 200 Coward Street
 MASCOT NSW 2020.

NOTE: This Certificate relates to the suitability of the pattern of the instrument for use for trade only in respect of its metrological characteristics. This Certificate does not constitute or imply any guarantee of compliance by the manufacturer or any other person with any requirements regarding safety.

This approval has been granted with reference to document NMI R 117-1, Measuring Systems for Liquids Other than Water, dated July 2004.

CONDITIONS OF APPROVAL

This approval becomes subject to review on 1 September 2011, and then every 5 years thereafter.

Instruments purporting to comply with this approval shall be marked with approval number 'NMI S509' and only by persons authorised by the submitter.

Instruments incorporating a component purporting to comply with this approval shall be marked 'NMI S509' in addition to the approval number of the instrument.

It is the submitter's responsibility to ensure that all instruments marked with this approval number are constructed as described in the documentation lodged with the National Measurement Institute (NMI) and with the relevant Certificate of Approval and Technical Schedule. Failure to comply with this Condition may attract penalties under Section 19B of the National Measurement Act and may result in cancellation or withdrawal of the approval, in accordance with document NMI P 106.

The National Measurement Institute reserves the right to examine any instrument or component of an instrument purporting to comply with this approval.

Auxiliary devices used with this instrument shall comply with the requirements of General Supplementary Certificate No S1/0/A.

DESCRIPTIVE ADVICE

Pattern: approved 25 January 2008

- A Coles Express model ST2 control system for use with compatible approved fuel dispensers for motor vehicles.

Technical Schedule No S509 describes the pattern.

Variant: approved 24 October 2008

1. For use to control additional meters/hoses.

Technical Schedule No S509 Variation No 1 describes variant 1.

FILING ADVICE

Supplementary Certificate of Approval No S509 dated 30 January 2008 is superseded by this Certificate, and may be destroyed. The documentation for this approval now comprises:

Supplementary Certificate of Approval No S509 dated 27 October 2008
Technical Schedule No S509 dated 30 January 2008 (incl. Test
Procedure)

Technical Schedule No S509 Variation No 1 dated 27 October 2008
Figures 1 to 3 dated 30 January 2008

Signed by a person authorised by the Chief Metrologist
to exercise his powers under Regulation 60 of the
National Measurement Regulations 1999.



TECHNICAL SCHEDULE No S509

Pattern: Coles Express Model ST2 Control System for Fuel Dispensers for Motor Vehicles

Submittor: WorkVentures Ltd
(trading as Sydney ITeC Repair Centre)
Unit A1, 200 Coward Street
MASCOT NSW 2020

1. Description of Pattern

The pattern is a Coles Express model ST2 point of sale control system (Figure 1) to provide an attended self-service facility for compatible (#) approved fuel dispensers for motor vehicles. The fuel dispensers are controlled by the ST2 control system through the Coles Express 9650 series flowmeter controller.

1.1 Field of Operation

- The model ST2 POS 4650 operator console and the model ST2 POS 9650 flowmeter controller (Figure 2) are approved for environmental class A, a climate-controlled environment between 5°C and 30°C.
- The system can provide a self-serve arrangement for up to 32 approved fuel dispensers fitted with approved Transponder Technologies model T5 indicators, or other compatible (#) approved fuel dispensers.
- The system allows post-payment deliveries only.
- The system allows up to two transactions per fuel dispenser, i.e. current sale on the fuel dispenser and a stored transaction.
- The system operates in a single mode operation, i.e. authorisation of dispensers via attended method only.
- Up to six ST2 POS 4650 operator consoles may be interfaced for multi-attended self-serve operation.
- The nominal supply voltage is 240 V AC.

1.2 System Description

(i) Operator Console

The ST2 POS 4650 operator console (Figure 2) is comprised of an interactive touch-sensitive operator display and a programmable keyboard, operating with Coles Express version 43 software.

- (#) 'Compatible' is defined to mean that no additions/changes to hardware/software are required for satisfactory operation of the complete system.

(ii) Flowmeter Controller

The ST2 POS 9650 controller (Figure 2) provides control and data acquisition between the operator console and up to 16 compatible (#) approved fuel dispensers.

A master controller contains a server logic board which controls a local area network (LAN) to provide a multiple-console arrangement with up to five slave control units. One of the additional slave units can be configured to provide control and data acquisition to 16 additional fuel dispensers.

The ST2 POS 9650 controller includes the following additional components:

- A SOLA uninterruptible power supply (UPS) of 300 VA rating or equivalent compatible (#) UPS. (Note that the submitter should be consulted regarding any acceptable alternative UPS.)
- A Coles Express 2x20 segment model ICD-2002 customer display (Figure 2).
- A CBM model 1000 receipt printer (Figure 2). Sample receipts are shown in Figure 3.

(iii) Additional System Facilities

The ST2 POS system may include point of sale facilities including a cash drawer, car wash authorisation, a magnetic card or barcode reader and electronic funds transfer (EFT) facility. The facilities shall not interact with the console in a way that would cause an incorrect indication of the measured volume or price.

(#) 'Compatible' is defined to mean that no additions/changes to hardware/software are required for satisfactory operation of the complete system.

1.3 Checking Facilities

(i) Uninterruptible Power Supply (UPS)

The system monitors the condition of the UPS and, if no connection between the UPS and the controller is detected, a visual warning is displayed on the operator's screen. The ability to authorise a stored transaction will be prevented until the detected error condition is resolved.

(ii) Printer

If the printer is unavailable a message is displayed on the operator console reporting the details of the error that has occurred.

(iii) Customer Display

If the connection to the customer display is interrupted the memory storage ability will be disabled. An error message is also displayed on the operator console warning that the memory function is disabled. A visual checking facility is provided to verify display operation.

(iv) Communication

The system monitors the communication with the fuel dispensers and any error detected is displayed to the operator.

1.4 Verification/Certification Provision

The ST2 POS has provision for a certification/Verification mark to be applied.

1.5 Markings

The operator console and the controller are each marked with the following data:

Manufacturer's identification mark or trade mark	Coles Express
Manufacturer's designation (model number)
Serial number
Year of manufacture
Pattern approval mark	S509
Operating (air) temperature range	5°C to 30°C

TEST PROCEDURE

Instruments shall be tested in conjunction with any tests specified in the approval documentation for the instruments to which the pattern is connected, as appropriate, and in accordance with any relevant tests specified in the Uniform Test Procedures.

Points 2-4 are required at commissioning, thereafter may be conducted at the discretion of the inspecting officer.

1. Check the ST2 POS software version. Selecting [levl2] on the touch screen, followed by the [levl3], [levl4] and [PrnFcn] then pressing the Enter button on the keyboard will print the software version.
2. Check that the unit price change for the grade of fuel is implemented to the allocated fuel dispensers when they are available for authorisation.
3. Check that the control console and the customer display identify and display the correct data for the corresponding number allocated to the fuel dispenser.
4. Check that for both the UPS and the customer display, when each is disconnected from the controller (simulation of fault), a warning is displayed and the fuel dispenser cannot be authorised for a second delivery unless the transaction for the first delivery has been completed.

TECHNICAL SCHEDULE No S509

VARIATION No 1

Pattern: Coles Express Model ST2 Control System for Fuel Dispensers for Motor Vehicles

Submittor: WorkVentures Ltd
(trading as Sydney ITeC Repair Centre)
Unit A1, 200 Coward Street
MASCOT NSW 2020

1. Description of Variant 1

With the Solution Technology model ST2 POS 4650 operator console described for the pattern now with alternative software allowing the console to communicate with additional meters/hoses.

The system (as described for the pattern in Technical Schedule No S509 dated 30 January 2008) can provide a self-serve arrangement for a number of approved fuel dispensers.

Each dispenser may be fitted with more than 1 'indicating system' – an indicating system is here defined as a single indicating unit connected to a number of meters/hoses.

When the model ST2 POS 4650 operator console operates with SFUELREC version S00044 software, each indicating system may include up to six meters/hoses. The software version in use may be checked using the method set out in the TEST PROCEDURE included in Technical Schedule No S509.

NOTIFICATION OF CHANGE

In Technical Schedule No S509 dated 30 January 2008;

A. In clause **1.1 Field of Operation**, the 2nd bullet point should be amended as shown below:

“... arrangement for up to **16** approved fuel dispensers ...”

B. In clause **1.2 System Description**, the 1st paragraph in subclause **(ii) Flowmeter Controller** should be amended as shown below:

“... and up to **8** compatible (#) approved fuel dispensers.”

C. In clause **1.2 System Description**, the 2nd paragraph in subclause **(ii) Flowmeter Controller** should be amended as shown below:

“... data acquisition to **8** additional approved fuel dispensers.”

FIGURE S509 – 1

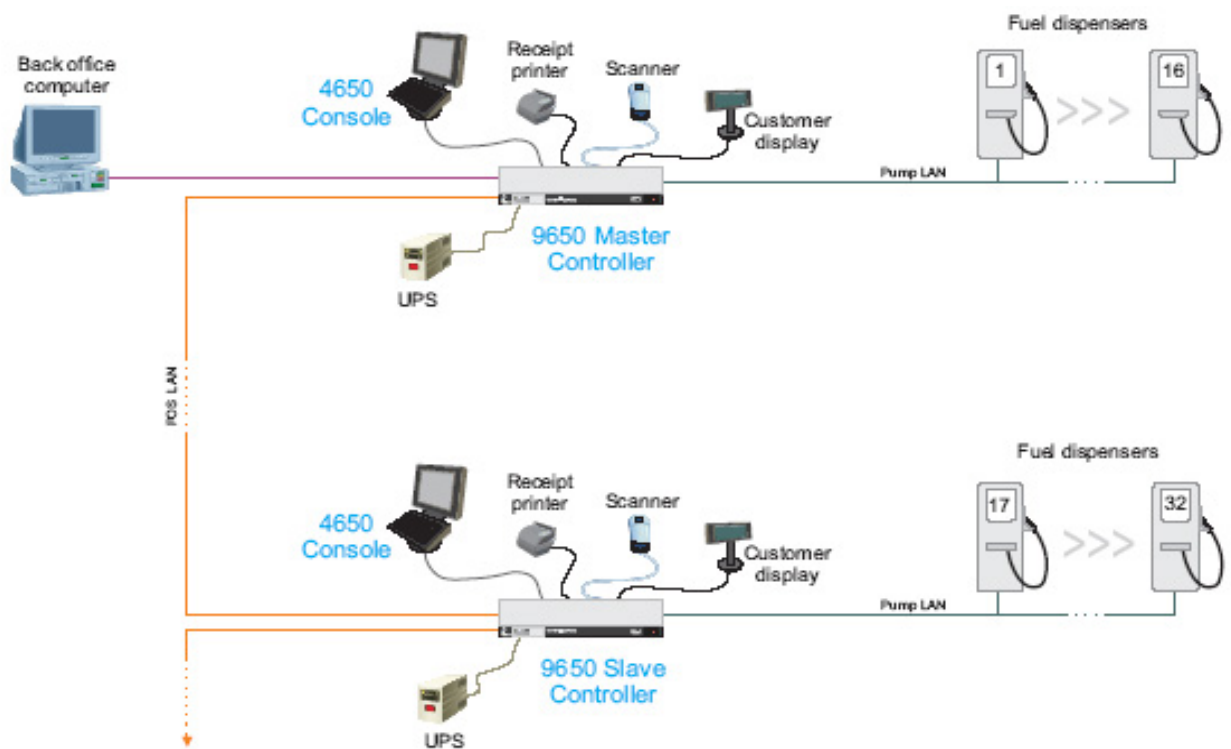

FIGURE S509 – 2



4650 Operator Console



9650 Flowmeter Controller (front view)



9650 Flowmeter Controller (rear view)



ICD2002 Customer Display



CBM1000 Receipt Printer

Major Components of a POS Control System

