



**Australian Government**  
**National Measurement  
Institute**

Bradfield Road, West Lindfield NSW 2070

**Cancellation**  
**Supplementary Certificate of Approval**  
**No S386**

Issued by the Chief Metrologist under Regulation 60  
of the  
*National Measurement Regulations 1999*

This is to certify that the approval for use for trade granted in respect of the  
Avery Berkel Model T302 Load Cell

submitted by      Avery Weigh-Tronix  
                         Foundry Lane  
                         Smethwick  
                         West Midlands      B66 2LP      UK

has been cancelled in respect of new instruments as from 1 March 2012.

Signed by a person authorised by the Chief Metrologist  
to exercise his powers under Regulation 60 of the  
*National Measurement Regulations 1999*.

A handwritten signature in black ink, consisting of a series of loops and flourishes, positioned to the right of the signature text.



## National Standards Commission

12 Lyonpark Road, North Ryde NSW

### Supplementary Certificate of Approval

**No S386**

Issued under Regulation 60  
of the  
National Measurement Regulations 1999

This is to certify that an approval for use for trade has been granted in respect of the

Avery Berkel Model T302 Load Cell

submitted by **Avery Berkel International**  
Foundry Lane  
Smethwick  
West Midlands B66 2LP  
UK.

**NOTE:** This Certificate relates to the suitability of the pattern of the instrument for use for trade only in respect of its metrological characteristics. This Certificate does not constitute or imply any guarantee of compliance by the manufacturer or any other person with any requirements regarding safety.

### CONDITIONS OF APPROVAL

This approval becomes subject to review on 1 April 2006, and then every 5 years thereafter.

Instruments purporting to comply with this approval shall be marked NSC No S386 and only by persons authorised by the submitter.

Instruments incorporating a component purporting to comply with this approval shall be marked NSC No S386 in addition to the approval number of the instrument.

It is the submitter's responsibility to ensure that all instruments marked with this approval number are constructed as described in the documentation lodged with the Commission and with the relevant Certificate of Approval and Technical Schedule. Failure to comply with this Condition may attract penalties under Section 19B of the National Measurement Act and may result in cancellation or withdrawal of the approval, in accordance with the Commission's Document NSC P 106.

The Commission reserves the right to examine any instrument or component of an instrument purporting to comply with this approval.

### DESCRIPTIVE ADVICE

**Pattern:** approved 9 March 2001

- An Avery Berkel model T302 load cell of 22 500 kg maximum capacity.

**Variant:** approved 9 March 2001

1. Of 45 000 kg maximum capacity.

Technical Schedule No S386 describes the pattern and variant 1.

### FILING ADVICE

The documentation for this approval comprises:

Supplementary Certificate of Approval No S386 dated 30 April 2001  
Technical Schedule No S386 dated 30 April 2001 (incl. Table 1)  
Figures 1 and 2 dated 30 April 2001

Signed by a person authorised under Regulation 60 of the National Measurement Regulations 1999 to exercise the powers and functions of the Commission under this Regulation.



TECHNICAL SCHEDULE No S386

**Pattern:** Avery Berkel Model T302 Load Cell.

**Submittor:** Avery Berkel International  
Foundry Lane  
Smethwick  
West Midlands B66 2LP  
UK.

### 1. Description of Pattern

An Avery Berkel model T302 load cell of 22 500 kg maximum capacity (Figure 1 and Table 1) approved for use with up to 4000 verification intervals.

#### 1.1 Method of Mounting

Mounting is to be in accordance with the manufacturer's instructions and as shown in Figure 2.

#### 1.2 Markings

Each load cell is marked with the following:

Manufacturer's mark, or name written in full	.....
Model number	.....
Serial number	.....
Pattern approval mark	NSC No S386
Maximum capacity $E_{max}$	..... kg or t
Classification	C4

#### 1.3 Table of Specifications

Specifications for the pattern are given in Table 1.

### 2. Description of Variant 1

Of 45 000 kg maximum capacity as listed in Table 1.

**TABLE 1**

Type: Avery Berkel model T302



Maximum capacity, $E_{max}$	kg	22 500	45 000
Classification		C4	C4
Maximum number of verification intervals		4000	4000
Minimum value of verification interval, $v_{min}$	kg	2.75	5.50
Minimum dead load output return value (DR)	kg	2.25	4.50
Output rating (nominal)	mV/V	1.7	1.7
Input impedance (nominal)	$\Omega$	480	480
Supply voltage (AC or DC)	V	10 - 12	10 - 12
Cable length ( $\pm 0.1$ m)	m	25 and 40	25 and 40
Number of leads (plus shield)		4	4



**Australian Government**  

---

**National Measurement  
Institute**

Bradfield Road, West Lindfield NSW 2070

**Notification of Change**  
**Supplementary Certificate of Approval No S386**  
**Change No 1**

Issued by the Chief Metrologist under Regulation 60  
of the  
*National Measurement Regulations 1999*

The following changes are made to the approval documentation for the

Avery Berkel Model T302 Load Cell

submitted by Avery Berkel International  
Foundry Lane  
Smethwick  
West Midlands B662LP  
UNITED KINGDOM.

- A. In Supplementary Certificate of Approval No S386 dated 30 April 2001 and its Technical Schedule, all references to the name of the submitter should be amended to read:

“Avery Weigh-Tronix.”

- B. In Supplementary Certificate of Approval No S386 dated 30 April 2001;
- (i) The Condition of Approval referring to the review of the approval should be amended to read:
- “This approval becomes subject to review on 1 April 2011, and then every 5 years thereafter.”

- (ii) In the DESCRIPTIVE ADVICE, the description of the pattern should be amended by adding the following:  
“May also be known as Avery Weigh-Tronix load cells of the same model.”
- C. In Technical Schedule No S386 dated 30 April 2001;
  - (i) In clause **1. Description of Pattern**, the first paragraph should be amended by adding the following:  
“May also be known as Avery Weigh-Tronix load cells of the same model.”
  - (ii) In TABLE 1, the first line should be amended by adding the following:  
“May also be known as Avery Weigh-Tronix load cells of the same model.”

Signed by a person authorised by the Chief Metrologist  
to exercise his powers under Regulation 60 of the  
*National Measurement Regulations 1999.*

A handwritten signature in black ink, appearing to be 'J. H. T.', written in a cursive style.



**Australian Government**  
**National Measurement  
Institute**

Bradfield Road, West Lindfield NSW 2070

**Notification of Change**  
**Supplementary Certificate of Approval No S386**  
**Change No 2**

Issued by the Chief Metrologist under Regulation 60  
of the  
*National Measurement Regulations 1999*

The following changes are made to the approval documentation for the

Avery Berkel Model T302 Load Cell

submitted by Avery Weigh-Tronix  
Foundry Lane  
Smethwick  
West Midlands B662LP  
UNITED KINGDOM.

- A. In Supplementary Certificate of Approval No S386 dated 30 April 2001, the FILING ADVICE should be amended as follows:
1. Remove the text "(incl. Table 1)"
  2. Insert new lines of text, namely  
"Table 1 dated 12 June 2007  
Notification of Change No 1 dated 4 August 2006  
Notification of Change No 2 dated 12 June 2007"
- B. In Technical Schedule No S386 dated 30 April 2001, Table 1 (on page 2) is replaced by the attached Table 1 dated 12 June 2007.

Signed by a person authorised by the Chief Metrologist  
to exercise his powers under Regulation 60 of the  
*National Measurement Regulations 1999*.

A handwritten signature in black ink, appearing to be 'J. G. T.', written in a cursive style.



**TABLE 1**

Type: Avery Berkel model T302 (May also be known as Avery Weigh-Tronix load cells of the same model)

Maximum capacity, $E_{max}$	kg	22 500	45 000
Classification		C4	C4
Maximum number of verification intervals		4000	4000
Minimum value of verification interval, $v_{min}$	kg	2.75	5.50
Minimum dead load output return value (DR)	kg	2.25	4.50
Output rating (nominal)	mV/V	1.74	1.74
Input impedance (nominal)	$\Omega$	<b>540</b>	<b>540</b>
Supply voltage (AC or DC)	V	10 - 12	10 - 12
Cable length ( $\pm 0.1$ m)	m	25 and 40	25 and 40
Number of leads (plus shield)		4	4



**Australian Government**  
**National Measurement**  
**Institute**

Bradfield Road, West Lindfield NSW 2070

**Notification of Change**  
**Supplementary Certificate of Approval No S386**  
**Change No 3**

Issued by the Chief Metrologist under Regulation 60  
of the  
*National Measurement Regulations 1999*

The following changes are made to the approval documentation for the

Avery Berkel Model T302 Load Cell

submitted by Avery Weigh-Tronix  
Foundry Lane  
Smethwick  
West Midlands B662LP  
UNITED KINGDOM.

- A. In Supplementary Certificate of Approval No S386 dated 30 April 2001, the FILING ADVICE should be amended by adding the following:

“Notification of Change No 3 dated 30 July 2008”

- B. In Supplementary Certificate of Approval No S386 and its Technical Schedule both dated 30 April 2001, all references to the name of the submitter or manufacturer should be amended to read:

“Avery Weigh-Tronix **Ltd**”

Note: Notification of Change No 1 allows Avery Berkel instruments to also be known as Avery Weigh-Tronix instruments of the same model.

Signed by a person authorised by the Chief Metrologist to exercise his powers under Regulation 60 of the *National Measurement Regulations 1999*.

A handwritten signature in black ink, appearing to be 'J. H. T.', is located in the bottom right corner of the page.



**Australian Government**  
**National Measurement  
Institute**

Bradfield Road, West Lindfield NSW 2070

**Notification of Change**  
**Supplementary Certificate of Approval No S386**  
**Change No 4**

Issued by the Chief Metrologist under Regulation 60  
of the  
*National Measurement Regulations 1999*

The following changes are made to the approval documentation for the

Avery Berkel Model T302 Load Cell

submitted by Avery Weigh-Tronix Ltd  
Foundry Lane  
Smethwick  
West Midlands B662LP UNITED KINGDOM.

- A. In Supplementary Certificate of Approval No S386 dated 30 April 2001;
- (i) The following should be added to the CONDITIONS OF APPROVAL:  
**“Special:**  
Model T302 load cells of 45 000 kg capacity (Variant 1) may be used to replace some or all approved model 8701 load cells of 45 400 kg capacity in existing instruments. Refer to clause **2. Description of Variant 1** in Technical Schedule No S386 dated 30 April 2001.”
- (ii) The FILING ADVICE should be amended by adding the following:  
“Notification of Change No 4 dated 18 September 2008”
- B. In Technical Schedule dated 30 April 2001, clause **2. Description of Variant 1** should be amended by adding the following:  
“One or more model T302 load cells of 45 000 kg capacity (\*) may be used in the same instrument as a number of model 8701 load cells of 45 400 kg capacity which are described in the documentation of NSC approvals S204 and S204A. (Note that these approvals are no longer valid for NEW instruments, however the model T302 cells may be used to replace model 8701 cells in existing instruments.) Refer to the Special Condition of Approval.  
(\*) Does not apply to 22 500 kg capacity load cells.”

Signed by a person authorised by the Chief Metrologist  
to exercise his powers under Regulation 60 of the  
*National Measurement Regulations 1999*.

A handwritten signature in black ink, appearing to be 'J. G. T.', written in a cursive style.

FIGURE S386 - 1



Typical Avery Berkel T302 Load Cell

FIGURE S386 - 2

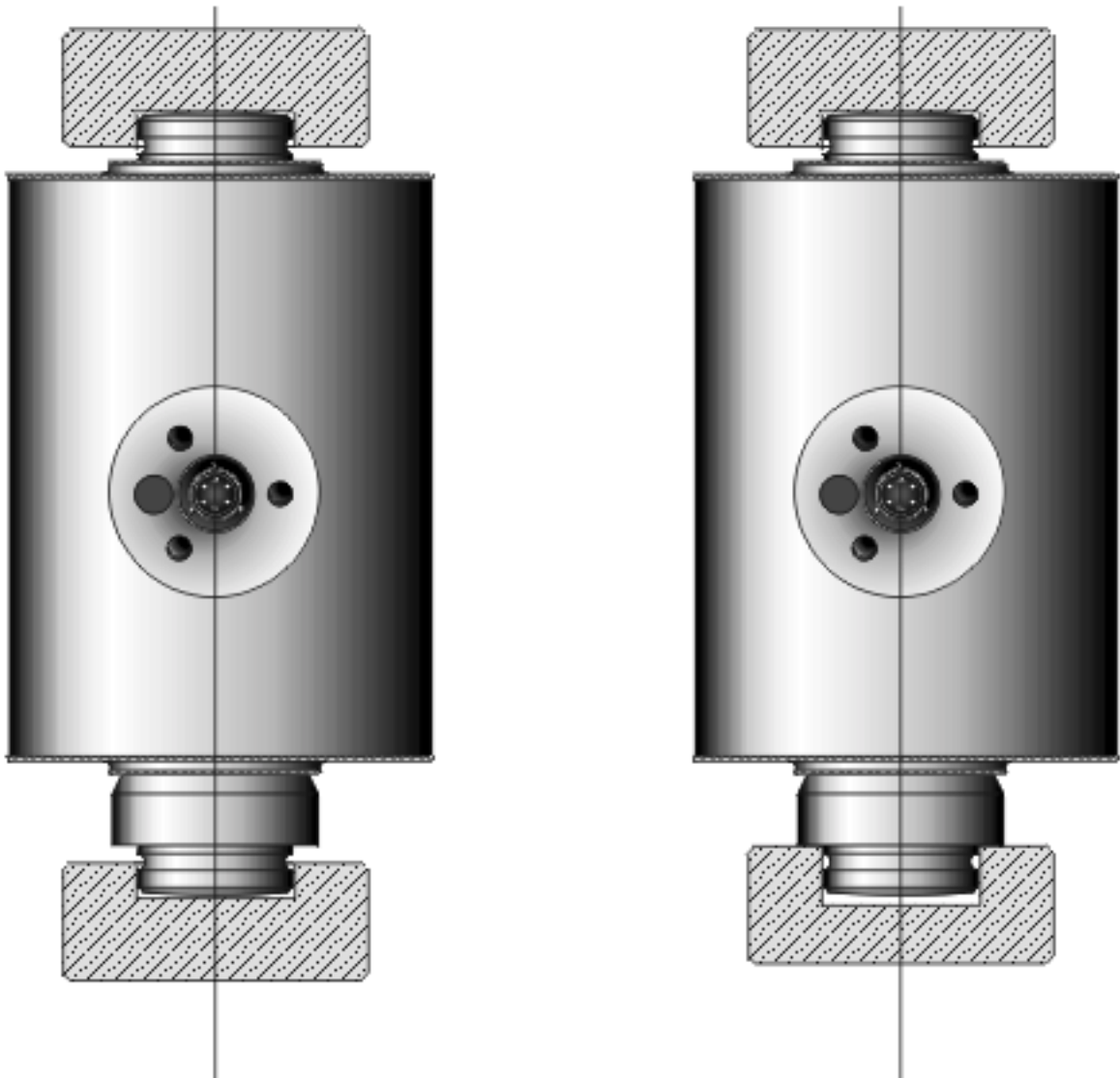

1) Rocking Pin or Strut

2) Base Mounting

Mounting Methods