

National Standards Commission

12 Lyonpark Road, North Ryde NSW

Cancellation

Supplementary Certificate of Approval

No S298

Issued under Regulation 60
of the
National Measurement Regulations 1999

This is to certify that the approval for use for trade granted in respect of the

GLOBAL Weighing Model PR6201/34H Load Cell

submitted by GWT GLOBAL Weighing Technologies GmbH
Meiendorfer Strasse 205
22145 Hamburg
GERMANY

has been cancelled in respect of new instruments as from 1 July 2002.

Signed by a person authorised under Regulation 60
of the National Measurement Regulations 1999 to
exercise the powers and functions of the Commission
under this Regulation.





National Standards Commission
Supplementary Certificate of Approval
No S298

Issued under Regulation 9
of the
National Measurement (Patterns of Measuring Instruments) Regulations

This is to certify that an approval for use for trade has been granted in respect of the

GLOBAL Weighing Model PR6201/34H Load Cell

submitted by GWT GLOBAL Weighing Technologies GmbH
Meiendorfer Strasse 205
22145 Hamburg
GERMANY.

NOTE: This Certificate relates to the suitability of the pattern of the instrument for use for trade only in respect of its metrological characteristics. This Certificate does not constitute or imply any guarantee of compliance by the manufacturer or any other person with any requirements regarding safety.

CONDITIONS OF APPROVAL

This approval becomes subject to review on 1 March 2003, and then every 5 years thereafter.

Instruments purporting to comply with this approval shall be marked NSC No S298 and only by persons authorised by the submittor.

Instruments incorporating a component purporting to comply with this approval shall be marked NSC No S298 in addition to the approval number of the instrument.

It is the submitter's responsibility to ensure that all instruments marked with this approval number are constructed as described in the documentation lodged with the Commission and with the relevant Certificate of Approval and Technical Schedule. Failure to comply with this Condition may attract penalties under Section 19B of the National Measurement Act and may result in cancellation or withdrawal of the approval, in accordance with the Commission's Document 106.

The Commission reserves the right to examine any instrument or component of an instrument purporting to comply with this approval.

DESCRIPTIVE ADVICE

Pattern: approved 25 February 1993
re-approved 18 August 1999

- A GLOBAL Weighing model PR6201/34H load cell of 30 000 kg maximum capacity. May also be known as Philips load cells of the same model.

Variant: approved 26 June 1995
re-approved 18 August 1999

1. In an alternative housing and known as a model PR6201/34C3.

Technical Schedule No S298 describes the pattern and variant 1.

FILING ADVICE

Supplementary Certificate of Approval No S298 dated 25 October 1995 and all other documentation including Technical Schedule No S298 and Figures 1 to 5 for this approval are superseded by the documentation listed below, and should be destroyed. The documentation for this approval now comprises:

Supplementary Certificate of Approval No S298 dated 29 October 1999
Technical Schedule No S298 dated 29 October 1999 (incl. Table 1)
Figures 1 to 5 dated 29 October 1999

Signed and sealed by a person authorised under Regulation 9 of the National Measurement (Patterns of Measuring Instruments) Regulations to exercise the powers and functions of the Commission under this Regulation.

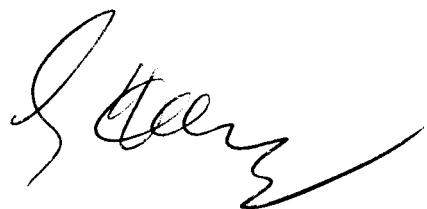
A handwritten signature in black ink, appearing to be 'J. Taylor', written in a cursive style.

TECHNICAL SCHEDULE No S298

Pattern: GLOBAL Weighing Model PR6201/34H Load Cell.

Submittor: GWT GLOBAL Weighing Technologies GmbH
Meiendorfer Strasse 205
22145 Hamburg
GERMANY.

1. Description of Pattern

A GLOBAL Weighing model PR6201/34H load cell of 30 000 kg maximum capacity (Table 1) approved for use with up to 4 000 verification scale intervals. May also be known as Philips load cells of the same model (Figure 1).

1.1 Method of Mounting

Mounting is to be in accordance with the manufacturer's instructions and as shown in Figures 2 to 4.

1.2 Markings

Each load cell is marked with the following:

Manufacturer's mark, or name written in full
Model number
Serial number
Pattern approval mark	NSC No S298
Maximum capacity E_{max} kg

1.3 Table of Specifications

Specifications for the pattern are given in Table 1.

2. Description of Variant 1

In an alternative housing and known as a model PR6201/34C3. May also be known as Philips load cells of the same model (Figure 5 and Table 1).

TABLE 1

Type: PR6201/34H or PR6201/34C3

Maximum capacity	kg	30 000
Accuracy class		C3
Maximum number of verification scale intervals		4000
Minimum value of verification scale interval	kg	1.530
Minimum dead load output return value (DR)	kg	1.665
Output rating (nominal)	mV/V	1.0
Input impedance (nominal)	Ω	650
Supply voltage (DC)	V	4 - 24
Cable length (± 0.1 m)	m	12, 15, 20 or 25
Number of leads (plus shield)		4

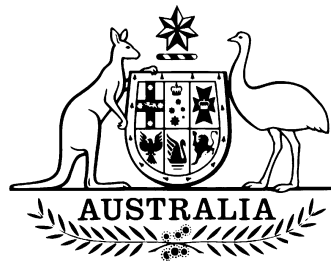

National Standards Commission

12 Lyonpark Road, North Ryde NSW

Notification of Change

Supplementary Certificate of Approval No S298

Change No 1

The following changes are made to the approval documentation for the
GLOBAL Weighing Model PR6201/34H Load Cell

submitted by GWT GLOBAL Weighing Technologies GmbH
Meiendorfer Strasse 205
22145 Hamburg
GERMANY.

- A. In Supplementary Certificate of Approval No S298 dated 29 October 1999, the FILING ADVICE should be amended by adding the following:

“Notification of Change No 1 dated 17 January 2001
Figure 6 dated 17 January 2001” (Note: Figure 6 is included herein.)

- B. In Technical Schedule No S298 dated 29 October 1999, the following should be added to clause 2. **Description of Variant 1:**

“When supplied without the upper and lower mounting plates (refer to Figures 1, 2 and 5) the load cell may also be known as a model PR6221/30t C3 (Figure 6). The mounting plates are available separately and the load cells shall continue to be used in accordance with the mounting methods shown in Figures 2 to 4.

Note: The load cell shown in Figure 5 is of a different capacity to the 30 000 kg load cell approved in this certificate and hence shows a different sized load button. The cable entry may be as shown in either of the styles shown in Figures 5 and 6.”

S298
17 January 2001

C. Figure S298 - 5 dated 29 October 1999 should be re-labelled as follows:

“PR6201 Series Load Cell (similar to the model PR6201/34 C3 but with a smaller load button)”

Signed by a person authorised under Regulation 60 of the National Measurement Regulations 1999 to exercise the powers and functions of the Commission under this Regulation.

A handwritten signature in black ink, reading "Jim Bennett". The signature is written in a cursive style with a large initial "J" and "B".

FIGURE S298 - 1



Model PR6201/34H Load Cell

FIGURE S298 - 2

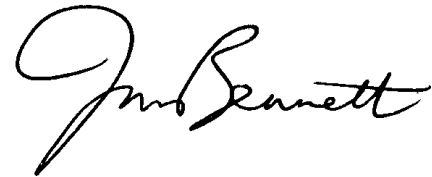
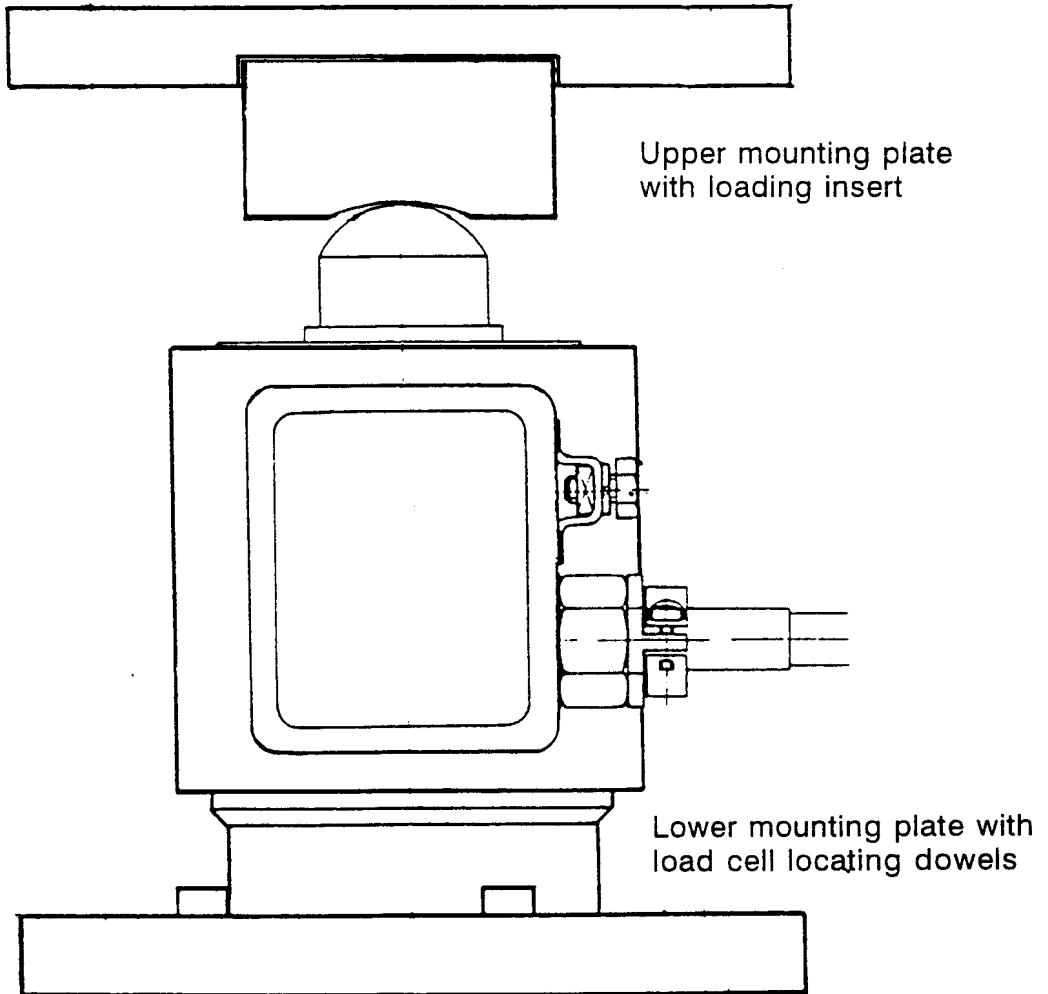

Mounting Method Without Horizontal Constrainers

FIGURE S298 - 3

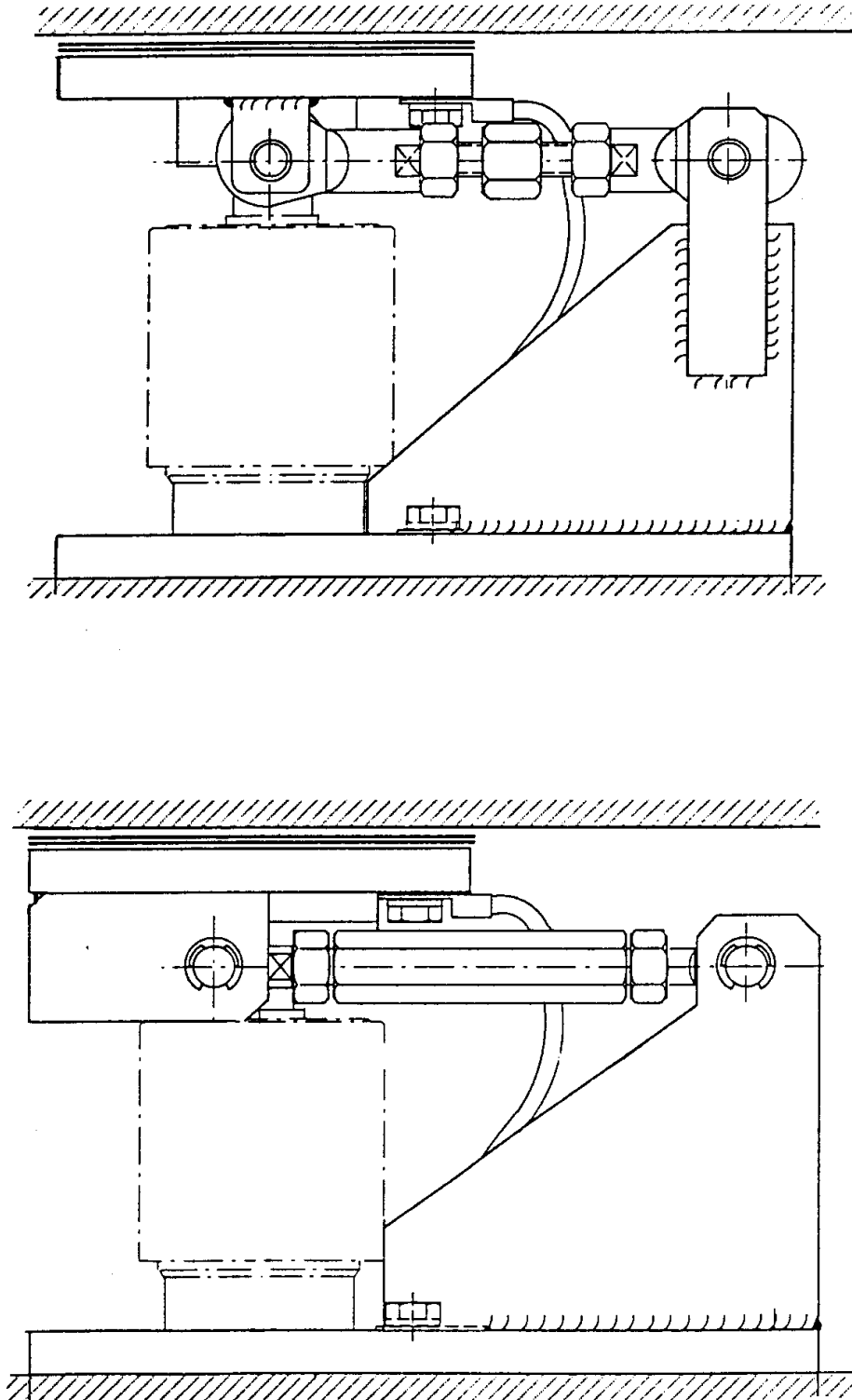

Typical Mounting Methods With Horizontal Constrainters

FIGURE S298 - 4

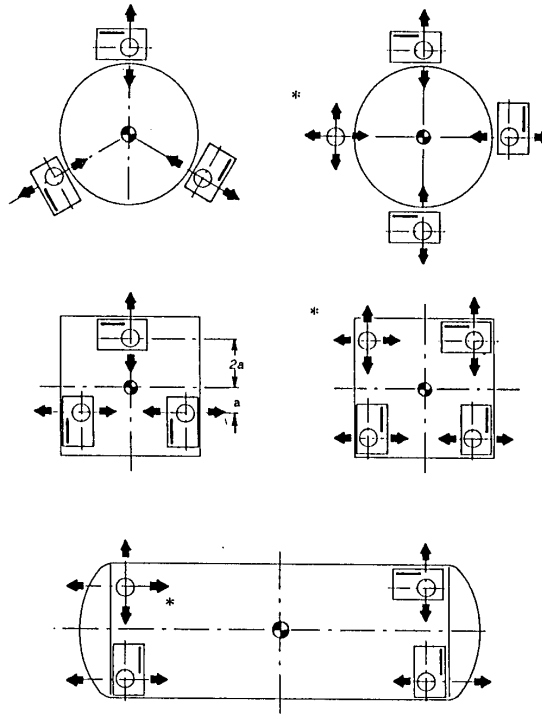

* This weighing point must not be constrained

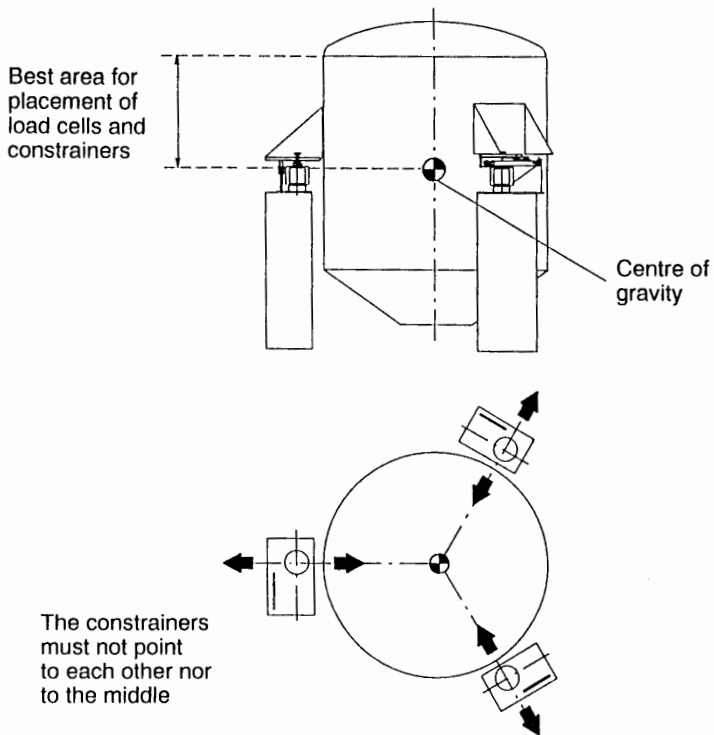

Showing Position of Load Cells and Horizontal Constrainters

FIGURE S298 - 5



Model PR6201/34C3 Load Cell

FIGURE S298 - 6



PR6221 Series Load Cell