



NATIONAL STANDARDS COMMISSION

WEIGHTS & MEASURES (PATTERNS OF INSTRUMENTS) REGULATIONS

REGULATION 9

SUPPLEMENTARY CERTIFICATE OF APPROVAL No S158

This is to certify that an approval has been granted by the Commission that the pattern of the

Gilbarco Model 102-ZVG 1.3 LPG Driveway Flowmeter Nozzle

submitted by Gilbarco Aust. Ltd
12-38 Talavera Road
North Ryde, New South Wales, 2113

is suitable for use for trade when used to replace the nozzle on any Commission-approved LPG driveway flowmeter.

The approval is subject to review on or after 1/10/88.

Instruments which incorporate a nozzle purporting to comply with this approval shall be marked NSC No S158 in addition to the approval number of the instrument and shall only be used in accordance with the drawings and specifications lodged with the Commission.

Condition of Approval

The nozzle is used only as a direct replacement of the existing nozzle, and only modifications to the boot to accommodate the nozzle are permitted. No alteration to the functions of the interlocks is permitted.

Signed

Executive Director

Descriptive Advice

Pattern: approved 7/9/83

Gilbarco model 102-ZVG 1.3 LPG driveway flowmeter nozzle (also known as an Elaflex).

Technical Schedule No S158 dated 23/9/83 describes the pattern.

Filing Advice

The documentation for this approval comprises:

Certificate of Approval No S158 dated 23/9/83
Technical Schedule No S158 dated 23/9/83
Test Procedure No S158 dated 23/9/83
Figures 1 and 2 dated 23/9/83.

23/9/83



NATIONAL STANDARDS COMMISSION

TECHNICAL SCHEDULE No S158

Pattern: Gilbarco Model 102-ZVG 1.3 LPG Driveway Flowmeter Nozzle

Submittor: Gilbarco Aust. Ltd
12-38 Talavera Road
North Ryde, New South Wales, 2113.

1. Description of Pattern

The pattern (Figures 1 and 2) is a driveway flowmeter nozzle suitable for liquefied petroleum gases and known as either a Gilbarco or an Elaflex model 102-ZVG 1.3.

The nozzle will only open when connected to a 1 3/4" Acme filler valve and is useable in both attendant-operated and self-serve situations, with or without a hold-open clip.

Refer to Condition of Approval.

1.1 Marking

The driveway flowmeter to which the nozzle is fitted as a replacement, should be marked NSC No S158 in addition to the approval number of the unmodified pattern.

TEST PROCEDURE No S158

TESTING OF INTERLOCKS

- (i) When fitted to an instrument with mechanical reset;

the replacement of the nozzle to its normal hang-up position, or what appears to be its normal hang-up position, shall not be possible until the starting lever has shut off the instrument and terminated the delivery.

- (ii) When fitted to an instrument with electrical reset;

the replacement of the nozzle to its normal hang-up position or what appears to be its normal hang-up position, shall not be possible unless:

- (a) If attendant-operated, the delivery is terminated and removal of the nozzle causes the display to revert to zero before a new delivery can commence, or
- (b) If self-serve, the delivery is terminated and removal of the nozzle causes an indication to appear at the console, requesting authorisation, and after authorisation the display reverts to zero before a new delivery can commence.

FIGURE 5158 - 1

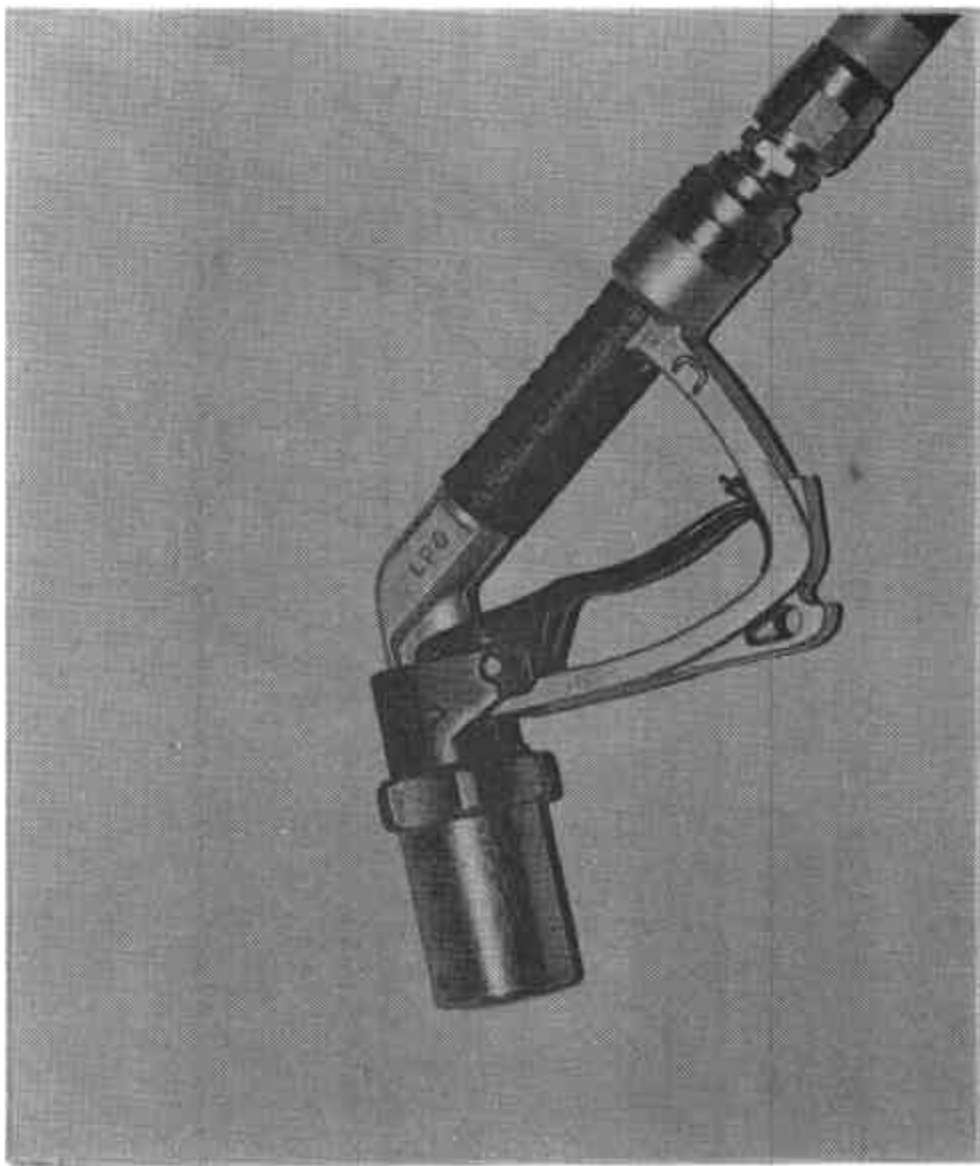

Gilbarco (or Elaflex) Model 102-ZVG 1.3 LPG Nozzle

23/9/83

Figure S158 - 2

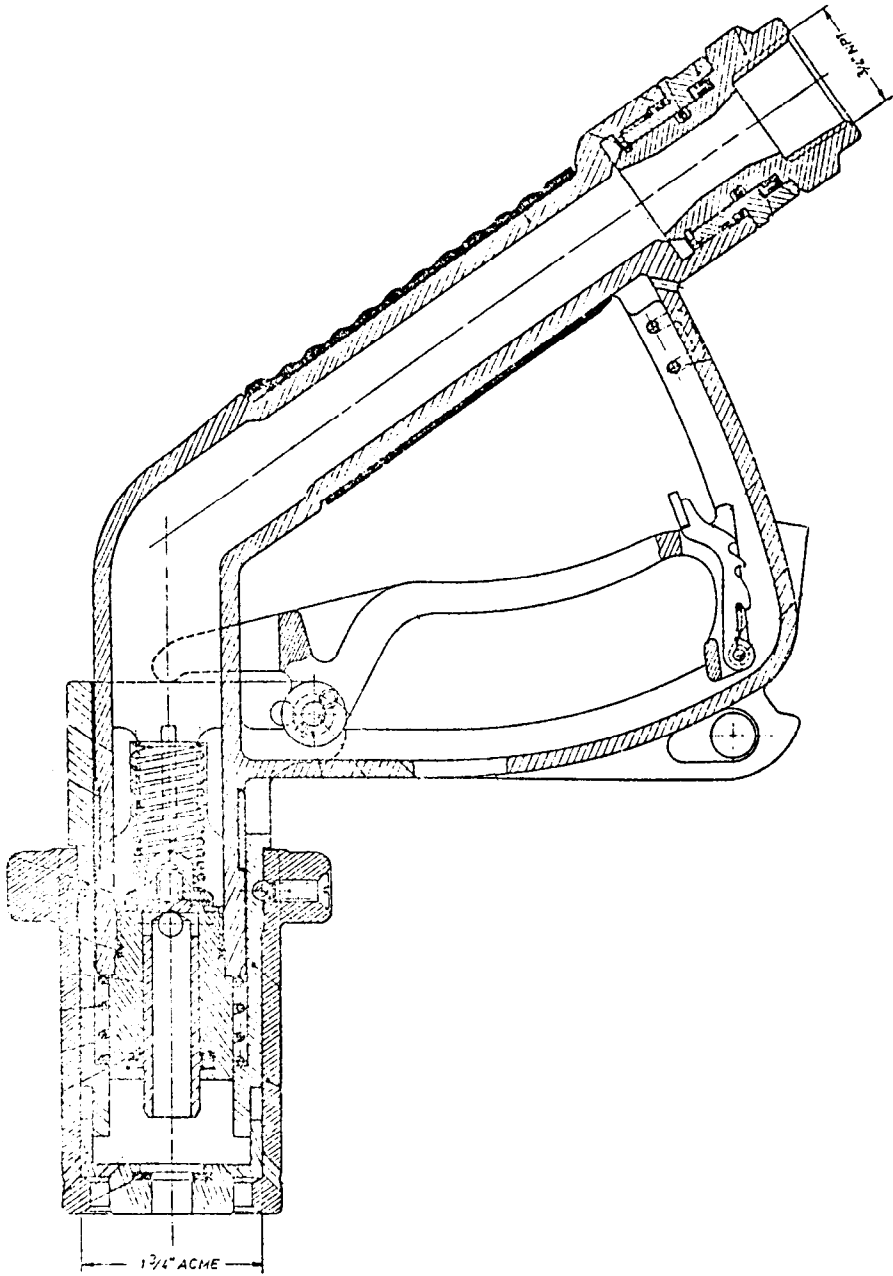

Schematic Of Model 102-ZVG 1.3

23/9/83