



NATIONAL STANDARDS COMMISSION

WEIGHTS & MEASURES (PATTERNS OF INSTRUMENTS) REGULATIONS

REGULATION 9

PROVISIONAL CERTIFICATE OF APPROVAL No P5/6B/62

This is to certify that an approval has been granted by the Commission that the pattern and variants of the

Pipeline/Loading Rack System With Brooks B-70 Series Flowmeter

submitted by K J Baillie Pty Ltd
12 Whiting Street
Artarmon, New South Wales, 2064

are suitable for use for trade.

The approval is subject to review on or after 1/1/85.

Instruments purporting to comply with this approval shall be marked NSC No P5/6B/62.

Conditions of Approval

1. The maximum and minimum permissible flow rates are 2082 L/min and 415 L/min for the pattern and 1600 L/min and 320 L/min for variant 1.
2. When the difference between maximum and minimum flow rates, in normal conditions of use, exceeds 10% of maximum flow rate, these maximum and minimum flow rates shall be marked on the data plate.

When the flow rate, in normal conditions of use, is within $\pm 5\%$ of a nominal flow rate, the nominal flow rate shall be marked on the data plate.
3. The instrument is not used for liquefied gases.
4. For the pattern and variants 1 to 6, the liquids measured are limited to petrol, kerosene, heating oil or distillate.
5. The type of liquid for which the instrument is verified is marked on the data plate.
6. The system is designed so that gas cannot enter the meter.
7. Instruments are installed in the manner described in Technical Schedule No P5/6B/62.
8. Each system is tested in a manner approved by the Commission at intervals of approximately three months, or, if the through-put is less than 2 ML per month, at intervals of not less than 6 ML, such tests to be arranged by the submitter and the results to be sent to the Commission.
9. In the event of unsatisfactory performance, the approval may be cancelled.

10. This approval may be cancelled if suitable test results are not received by the Commission.
11. The Commission reserves the right to inspect any installation covered by this approval.

Signed



Executive Director

Descriptive AdvicePattern: approved 3/12/82

- . A pipeline or loading rack system with Brooks B-70 series flowmeter.

Variants: approved 3/12/82

1. With a Brooks B-72 series flowmeter replacing the B-70 series.
2. Without ticket printer.
3. Without preset-control indicator and preset valve.
4. With rigid extension between the meter and indicator.
5. Without pulse transmitter.
6. Without flow rate control valve.
7. For use with aqueous ammonia.

Technical Schedule No P5/6B/62 dated 27/6/83 describes the pattern and variants 1 to 7.

Filing Advice

The documentation for this approval comprises:

Certificate of Approval No P5/6B/62 dated 27/6/83
Technical Schedule No P5/6B/62 dated 27/6/83
Test Procedure No P5/6B/62 dated 27/6/83
Figures 1 to 4 dated 27/6/83.



NATIONAL STANDARDS COMMISSION

TECHNICAL SCHEDULE No P5/6B/62

Pattern: Pipeline/Loading Rack System With Brooks B-70 Series Flowmeter.

Submittor: K J Baillie Pty Ltd
12 Whiting Street
Artarmon, New South Wales, 2064.

1. Description of Pattern

1.1 Pipeline Flowmeter

Refer to Figure 1.

The system comprises:

1.1.1

Supply tank.

1.1.2 Pump

Mounted lower than the minimum height of the liquid in the supply tank; the supply pipe from the tank has a continuous fall to the pump; provision is made for a pressure gauge to be connected to the suction side of the pump; if the pump is not for the exclusive use of the flowmeter, the flow rate through the meter must stay within the flow rate range marked on the meter.

1.1.3

A non-return valve between the pump and the meter, or an arrangement of the components and the piping to keep the system full of liquid at all times.

1.1.4

Strainer*, with or without a gas separator.

1.1.5

Brooks Bi-rotor flowmeter.

1.1.6

One of the following combinations of assemblies:

- (a) Indicator model VR1624.
- (b) Indicator model VR1624 with accumulative or zero-start ticket printer.
- (c) Indicator model VR7887.
- (d) Indicator model VR7887 with accumulative or zero-start ticket printer.

The indicators and ticket printers are single-handle reset. A preset indicator and preset-control valve may be fitted to the indicator with or without a ticket printer. The preset indicator is not approved for trade use.

* The strainer is not a part of the measuring instrument examined and approved by the Commission.

1.1.7

A pulse transmitter with interface to a remote indicator which is not in use for trade.

1.1.8

Flow rate control valve.

1.1.9

Outlet-control valve located downstream of the meter with no intermediate outlet.

1.2 Loading-rack Flowmeter System

This system is identical to the pipeline system except for the outlet which is replaced by one of the following:

Top-loading arrangement (Figure 2) - the highest point of the pipework forms a weir at a fixed level from which the delivery pipe drains to the outlet for all configurations of the loading arm; the outlet-control valve is installed at or upstream of the highest point and a syphon breaker is installed to ensure complete draining of the pipework downstream of the weir.

OR

Bottom-loading arrangement - drybreak coupling located at the delivery point of the piping.

1.3 Features Common to Both Systems

1.3.1 Marking

The instrument is marked with the following, together in one location:

Manufacturer's name or mark	
Meter model	
Serial number	
NSC approval number	NSC No P5/6B/62
Maximum flow rate - 2082 L/min	(when operating over a range of more than 208 L/min)
Minimum flow rate - 415 L/min	
Nominal flow rate	(when flow rate is within ±5% of nominal)
Type of liquid for which the instrument is verified	
Minimum delivery	

1.3.2 Sealing and Verification

- (a) The indicator, ticket printer, preset indicator and pulse transmitter may be sealed by passing a sealing wire through the attachment-mounting bolts. The calibrator may be sealed by the same wire or a separate wire terminating beneath the lead stamping plug provided for verification.
- (b) The instrument data plate is attached to the instrument by a lead stamping plug or by threading the indicator sealing wire through a hole in the data plate.

1.4 Minimum Delivery

The following minimum deliveries are applicable:

- 100 L with indicator only;
- 200 L with zero-start printer and indicator;
- 400 L with accumulative-start printer and indicator.

2. Description of Variants2.1 Variant 1

With a Brooks B-72 series flowmeter replacing the B-70 series of the pattern.

The maximum and minimum permissible flow rates are 1600 L/min and 320 L/min respectively.

2.2 Variant 2

Without ticket printer.

2.3 Variant 3

Without preset-control indicator and preset valve.

2.4 Variant 4

With rigid extension between the meter and indicator.

2.5 Variant 5

Without pulse transmitter.

2.6 Variant 6

Without flow rate control valve.

2.7 Variant 7

For use with aqueous ammonia.

TEST PROCEDURE No P5/68/62

1. The instrument should be tested with the liquid for which it will be used and which is marked on the data plate.

The maximum permissible errors at verification are:

- (a) $\pm 0.3\%$ for any flow rate when operating over a flow rate range of more than 10% of maximum flow rate (but within the marked maximum and minimum flow rates); or
 - (b) $\pm 0.15\%$ when operating at a flow rate within $\pm 5\%$ of nominal as marked on the meter.
2. The maximum permissible variation between indicators is 0.2 scale intervals.
 3. If a device is fitted to prevent the level of the liquid in the supply tank falling to the level of the pump, at least one delivery should occur during which the device stops the delivery. It will be necessary to refill the supply tank to finish the delivery into the proving measure. The effect on the measurement of the quantity delivered should not exceed 1% of the minimum delivery.

Note: This test should only be done where it could be expected that the low-level device may operate during a normal day's delivery.

4. Test delivery - if the test delivery is less than ten times the minimum delivery, the reading error of the indicator or the rounding error of the ticket printer is minimised by completing the delivery at a graduation line.

The following information shall be recorded for sending to the Commission:

- (a) NSC approval number
- (b) Installation address
- (c) Meter serial number and model number
- (d) Identification of meter assembly in terms of pattern and variants described in this Schedule
- (e) Totaliser reading at beginning of test
- (f) Type of liquid
- (g) Temperature of liquid entering the meter
- (h) Information from the Weights and Measures inspection as to the calibration results recorded in 1. above.



NATIONAL STANDARDS COMMISSION

P5/6B/62
13/3/89

CANCELLATION CERTIFICATE OF APPROVAL No P5/6B/62

This is to certify that the approval for use for trade granted in respect of the pattern and variants of the

Pipeline/Loading Rack System With Brooks B-70 Series Flowmeter

submitted by Rosemount Instruments Pty Limited
(formerly submitted by K J Baillie Pty Ltd)
471 Mountain Highway
Bayswater VIC 3153.

has been cancelled in respect of new instruments as from 1 March 1989.

CONDITIONS OF CANCELLATION

Existing instruments, currently installed and verified, may be replaced by an identical instrument provided that the Commission is advised of each proposal prior to the installation taking place.

Such a refurbished system shall be verified using the maximum permissible errors applicable to the verification of the system when originally approved.

Signed

Executive Director

FIGURE P5/68/62 - 1

27/6/83

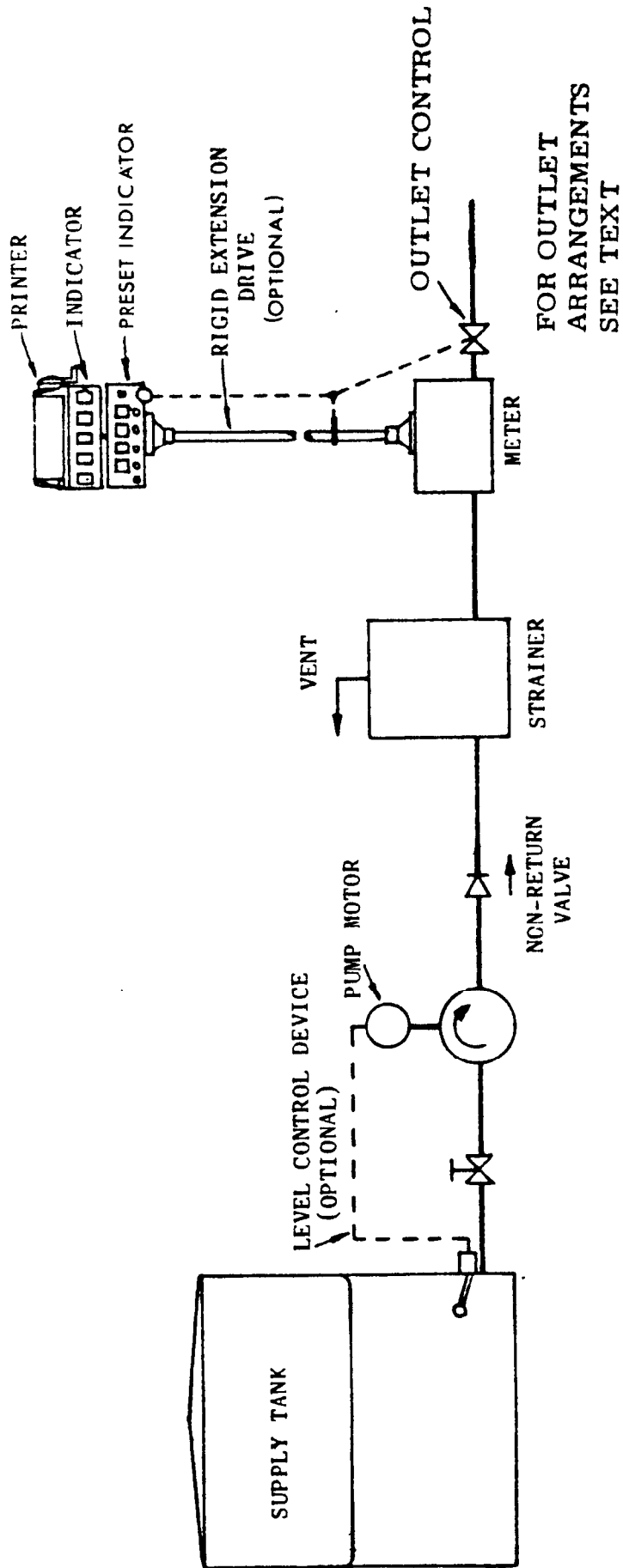

Pipeline Flowmeters - Schematic Diagram

FIGURE P5/68/62 - 2

27/6/83

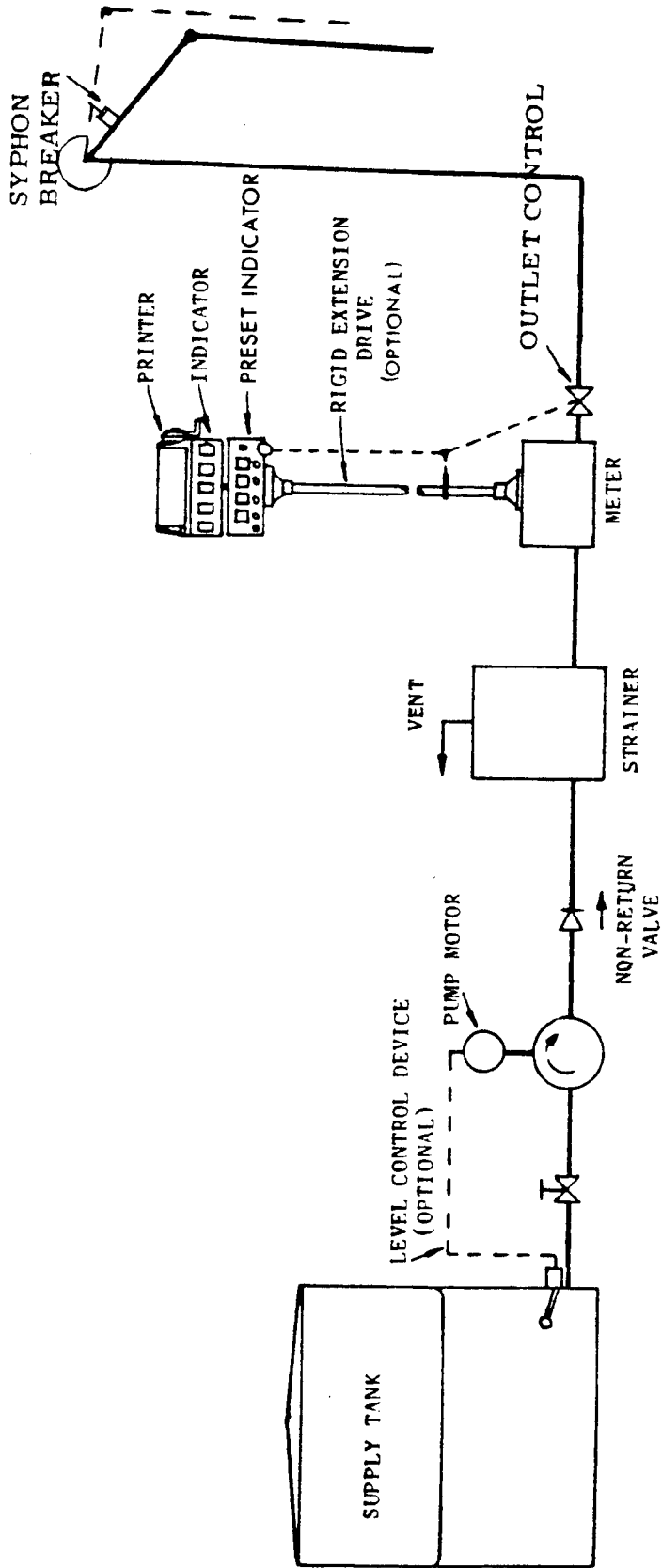

Loading-Rack Flowmeter - Schematic Diagram

FIGURE P5/68/62 - 4



An Alternative B-70 Series Arrangement

27/6/83

FIGURE P5/68/62 - 3



Brooks B-70 Series Flowmeter Including Strainer
(Without Gas Separator)