



NATIONAL STANDARDS COMMISSION

TECHNICAL SCHEDULE No 6/4A/7

Pattern: Avery 2414 Weighing (Counting) Instrument

Submitter: Avery Australia Ltd,
3-5 Birmingham Avenue,
Villawood, New South Wales, 2163.

Date of Approval: 14 November 1974

All instruments conforming to this approval shall be marked "NSC No 6/4A/7".

Description:

The pattern (see Figures 1 and 2) is for an Avery 2414 double-ratio counting machine of maximum capacity 3 kg. Balance is indicated by an optically projected line on a screen marked with three graduation lines denominated "2 g", "zero" and "2 g". Under-and-over weight indications are denominated by minus "-" and plus "+" signs respectively.

Two ratio pans are permanently fixed to the instrument, one a 10 : 1 ratio, the other a 100 : 1 ratio.

An ungraduated taring device operated by a knob on the side of the housing has a capacity of up to 600 g. The taring device is only graduated at zero; the capacity of the tare device is marked on the instrument data plate.

The zero is adjusted by a knob on the side of the housing.

The instrument is supported on four adjustable feet and is fitted with a level indicator. A notice adjacent to the level indicator is marked "instrument incorrect if not truly level".

The instrument data plate is marked -

1. "not for retail counter use";

2. "not to count items of weight less than 2 g";
3. "tare capacity t_g ";
4. "not to be used as a weighing instrument".

The approval also includes ratio pans of ratios 1 : 9 and 1 : 99.

Special Tests:

1. The optically projected line on the screen should indicate 2 g when a 2-g load is placed in the counting pan.
2. The optically projected line on the screen should indicate zero \pm 1 graduation when:
 - (a) 2 g is placed in the 10 : 1 ratio pan and 20 g is placed in the counting pan;
 - (b) 2 g is placed in the 100 : 1 ratio pan and 200 g is placed in the counting pan;
 - (c) 30 g is placed in the 100 : 1 ratio pan and 3000 g is placed in the counting pan; and
 - (d) 300 g is placed in the 10 : 1 ratio pan and 3000 g is placed in the counting pan.

* Note: "t" being the value of the tare capacity

12/2/75



NATIONAL STANDARDS COMMISSION

NOTIFICATION OF CHANGE

CERTIFICATE OF APPROVAL No 6/4A/7

CHANGE No 1

The Certificate of Approval Number, the Technical Schedule Number,
and the NSC Number for the

Avery 2414 Weighing (Counting) Instrument

approved by the Commission on 14 November 1974

have been changed from 6/4A/7 to 7/1. The 7/... series of numbers
in future will be used specifically for counting instrument approvals.

Signed

Executive Officer

15/4/75

FIGURE 6/4A/7 - 1

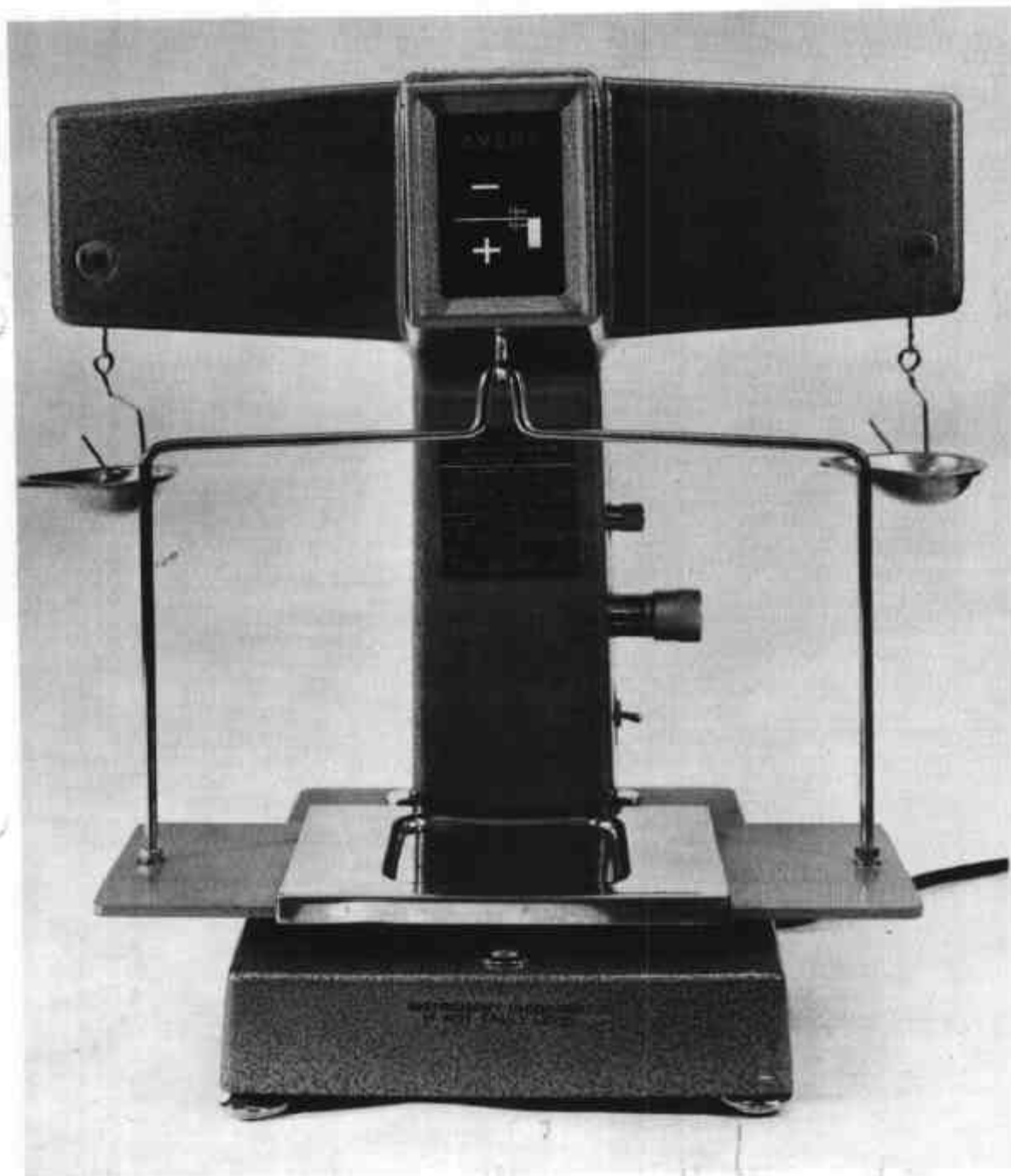

Avery 2414

12/2/75

FIGURE 6/4A/7 - 2

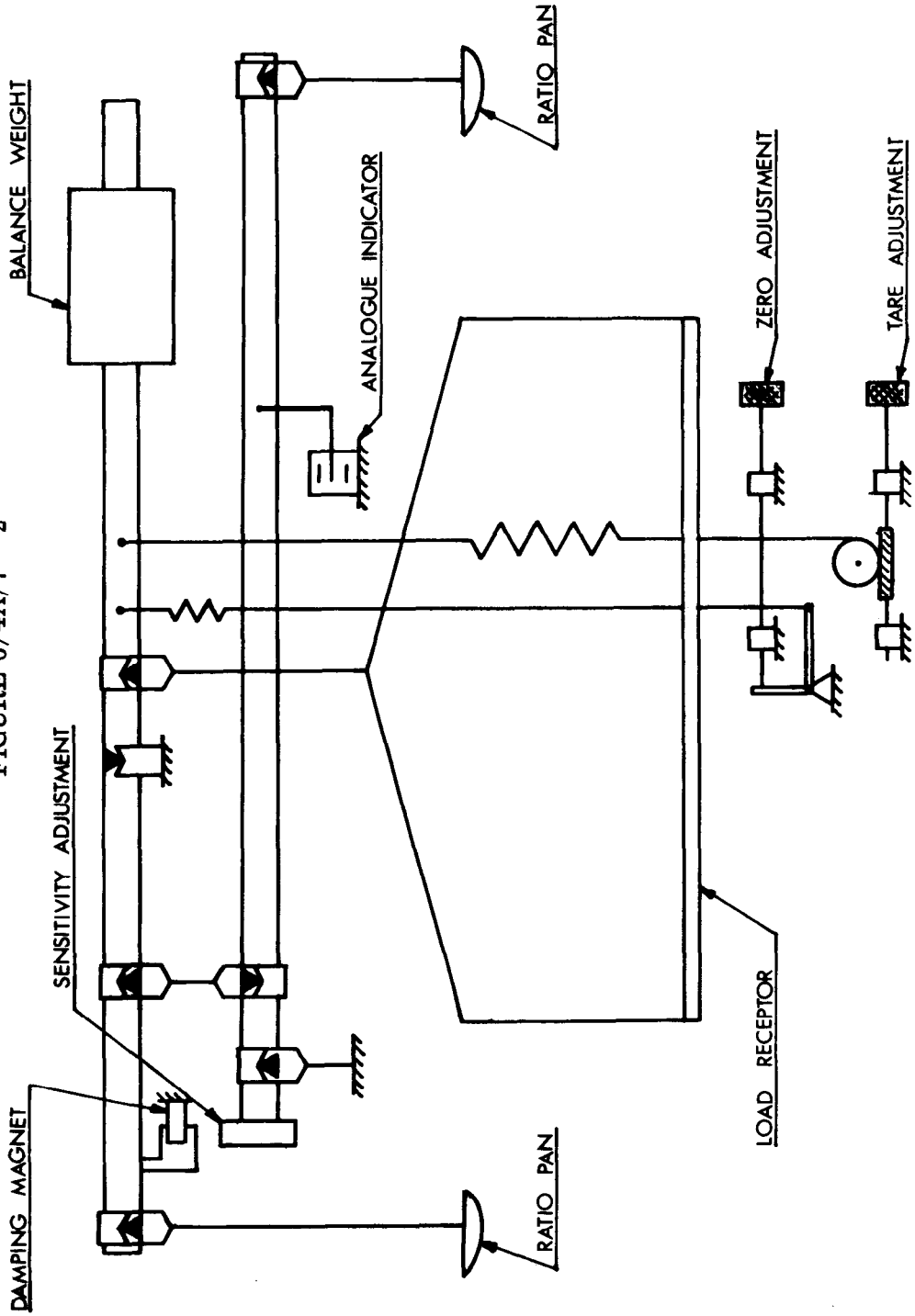

Avery 2414 - Schematic Diagram