



Australian Government
Department of Industry and Science

National Measurement Institute

36 Bradfield Road, West Lindfield NSW 2070

Certificate of Approval

NMI 6/4C/311

Issued by the Chief Metrologist under Regulation 60
of the
National Measurement Regulations 1999

This is to certify that an approval for use for trade has been granted in respect of the instruments herein described.

Teraoka Model Digi DSX-1000 Weighing Instrument

submitted by W W Wedderburn Pty Ltd
101 Williamson Road
Ingleburn NSW 2565.

NOTE: This Certificate relates to the suitability of the pattern of the instrument for use for trade only in respect of its metrological characteristics. This Certificate does not constitute or imply any guarantee of compliance by the manufacturer or any other person with any requirements regarding safety.

This approval has been granted with reference to document NMI R 76, *Non-automatic weighing instruments, Parts 1 and 2*, dated October 2015.

This approval becomes subject to review on 1/06/24, and then every 5 years thereafter.

DOCUMENT HISTORY

Rev	Reason/Details	Date
0	Pattern & variants 1 to 3 approved – certificate issued	22/05/19

CONDITIONS OF APPROVAL

General

Instruments purporting to comply with this approval shall be marked with pattern approval number 'NMI 6/4C/311' and only by persons authorised by the submittor.

It is the submittor's responsibility to ensure that all instruments marked with this approval number are constructed as described in the documentation lodged with the National Measurement Institute (NMI) and with the relevant Certificate of Approval and Technical Schedule. Failure to comply with this Condition may attract penalties under Section 19B of the National Measurement Act and may result in cancellation or withdrawal of the approval, in accordance with document NMI P 106.

Auxiliary devices used with this instrument shall comply with the requirements of General Supplementary Certificate No S1/0B.

Signed by a person authorised by the Chief Metrologist to exercise their powers under Regulation 60 of the *National Measurement Regulations 1999*.



Darryl Hines
Manager
Pattern Approval, Policy and
Licensing Section

TECHNICAL SCHEDULE No 6/4C/311

1. Description of Pattern **approved on 22/05/19**

A Teraoka model Digi DSX-1000 class III non-automatic self-indicating multi-interval weighing instrument (Figure 1) with a verification scale interval (e_1) of 0.002 kg up to 6 kg and a verification scale interval (e_2) of 0.005 kg from 6 kg up to the maximum capacity of 15 kg. The minimum capacity is 0.04 kg.

Instruments are fitted with an LCD colour touchscreen display/keyboard.

Instruments are not for trading direct with the public, and are so marked.

The instrument operates from mains AC power (100 - 240 V AC, 50/60 Hz).

Instruments may be fitted with output sockets (output interfacing capability) for the connection of peripheral and/or auxiliary devices.

1.1 Zero

A zero-tracking device may be fitted.

The initial zero-setting device of the pattern has a nominal range of not more than 20% of the maximum capacity of the instrument.

The instrument has a semi-automatic zero-setting device with a nominal range of not more than 4% of the maximum capacity of the instrument.

1.2 Tare

A semi-automatic subtractive tare device and/or non-automatic keyboard-entered pre-set subtractive tare device, each of up to 5.998 kg maximum tare capacity, may be fitted.

A separate display of tare values is provided.

1.3 Display Check

A display check is initiated whenever power is applied.

1.4 Levelling

The instrument is provided with adjustable feet and a level indicator.

The instrument is to be used in a level condition as indicated by the level indicator.

1.5 Additional Features

Instruments may be fitted with certain additional functions (e.g. check weighing (LOW/OK/HIGH), setting of target values, set-point, progress bar and totalisation).

The additional functions (other than the indications of measured mass, i.e. gross, tare, net, totals, displayed either on the indicator or on an auxiliary or peripheral device) are not approved for trade use.

1.6 Interfaces

The indicator may be fitted with interfaces for the connection of auxiliary and/or peripheral devices. Any interfaces shall comply with clause 5.3.6 of document NMI R 76 (the basic intent of which is that it shall not be possible to alter weighing results via the interfaces).

Any measurement data output from the instrument or its interfaces shall only be used for trade in compliance with NMI General Supplementary Certificate No S1/0B (in particular in regard to the data and its format).

Indications other than the indications of measured mass (i.e. gross, tare, net, totals) displayed either on the indicator or on an auxiliary or peripheral device, are not for trade use.

Instruments may be fitted with RS-232C serial interface and digital outputs (set-point interface).

1.7 Verification Provision

Provision is made for the application of a verification mark.

1.8 Descriptive Markings and Notices

Instruments carry the following markings:

Manufacturer's mark, or name written in full	Teraoka	
Name or mark of manufacturer's agent	WEDDERBURN	
Indication of accuracy class	Ⓜ	
Pattern approval number for the instrument	NMI 6/4C/311	
Maximum capacity	<i>Max</i>	g or kg #1
Minimum capacity	<i>Min</i>	g or kg #1
Verification scale interval	<i>e =</i>	g or kg #1
Maximum subtractive tare	<i>T = -</i>	g or kg #2
Serial number of the instrument	

#1 These markings are shown near the display of the result.

#2 This marking is required if *T* is not equal to *Max*.

In addition, instruments shall carry a notice stating NOT TO BE USED FOR TRADING DIRECT WITH THE PUBLIC, or similar wording.

Note: For multi-interval instruments the markings shall be as above, with the exception that the 'Maximum capacity' and 'Verification scale interval' shall be marked for both interval ranges, e.g. as follows:

Maximum capacity	<i>Max</i>/..... kg
Verification scale interval	<i>e =</i>/..... kg

1.9 Sealing Provision

Provision is made for access to the calibration switch to be sealed by means of lead and wire type seals with drilled screws, or destructible adhesive labels over the casing securing screw and calibration switch access hole underneath the instrument as shown in Figure 3.

1.10 Software

The software version is designated V01.xx, where 'xx' represents the identification of non-legally relevant software.

The software version and number can be seen by pressing the  key.

2. Description of Variant 1

approved on 22/05/19

Certain other capacities of the Teraoka model Digi DSX-1000 multi-interval instruments as listed in Table 1 below (the pattern is shown in **bold**).

TABLE 1

Maximum Capacity (<i>Max₁ / Max₂</i>)	Minimum Capacity (<i>Min</i>)	Verification Scale Interval (<i>e₁ / e₂</i>)	Maximum Subtractive Tare Capacity (<i>T = - ...</i>)
300 / 600 g	2 g	0.1 / 0.2 g	299.9 g
600 / 1.5 kg	4 g	0.2 / 0.5 g	599.8 g
1.5 / 3 kg	0.01 kg	0.0005 / 0.001 kg	1.4995 kg
3 / 6 kg	0.02 kg	0.001 / 0.002 kg	2.999 kg
6 / 15 kg	0.04 kg	0.002 / 0.005 kg	5.998 kg
15 / 30 kg	0.100 kg	0.005 / 0.010 kg	14.995 kg

3. Description of Variant 2

approved on 22/05/19

The Teraoka model Digi DSX-1000 of single interval instruments in certain capacities as listed in Table 2 below.

TABLE 2

Maximum Capacity (<i>Max</i>)	Minimum Capacity (<i>Min</i>)	Verification Scale Interval (<i>e</i>)	Maximum Subtractive Tare Capacity (<i>T = - ...</i>)
600 g	2 g	0.1 g	299.9 g
600 g	4 g	0.2 g	299.8 g
1.5 kg	0.010 kg	0.0005 kg	1.4995 kg
3 kg	0.010 kg	0.0005 kg	1.4995 kg
3 kg	0.020 kg	0.001 kg	1.499 kg
6 kg	0.020 kg	0.001 kg	2.999 kg
6 kg	0.040 kg	0.002 kg	2.998 kg
15 kg	0.100 kg	0.005 kg	7.495 kg
30 kg	0.100 kg	0.005 kg	14.995 kg
30 kg	0.200 kg	0.010 kg	14.99 kg

4. Description of Variant 3

approved on 22/05/19

Instruments which are similar to the pattern and variants 1 to 2 but having an integral printer (Figure 2). May also known as model DSX-1000P.

TEST PROCEDURE

Instruments shall be tested in accordance with any relevant tests specified in the National Instrument Test Procedures.

Maximum Permissible Errors

The maximum permissible errors are specified in Schedule 1 of the *National Trade Measurement Regulations 2009*.

Tests

For multi-interval instruments with verification scale intervals of $e_1, e_2 \dots$, apply e_1 for zero adjustment, and maximum permissible errors apply $e_1, e_2 \dots$, as applicable for the load.

FIGURE 6/4C/311 – 1



Teraoka Model Digi DSX-1000 Weighing Instrument (Pattern)

FIGURE 6/4C/311 – 2



Teraoka Model Digi DSX-1000 Weighing Instrument with an integral printer
(Variants 3)

FIGURE 6/4C/311 – 3

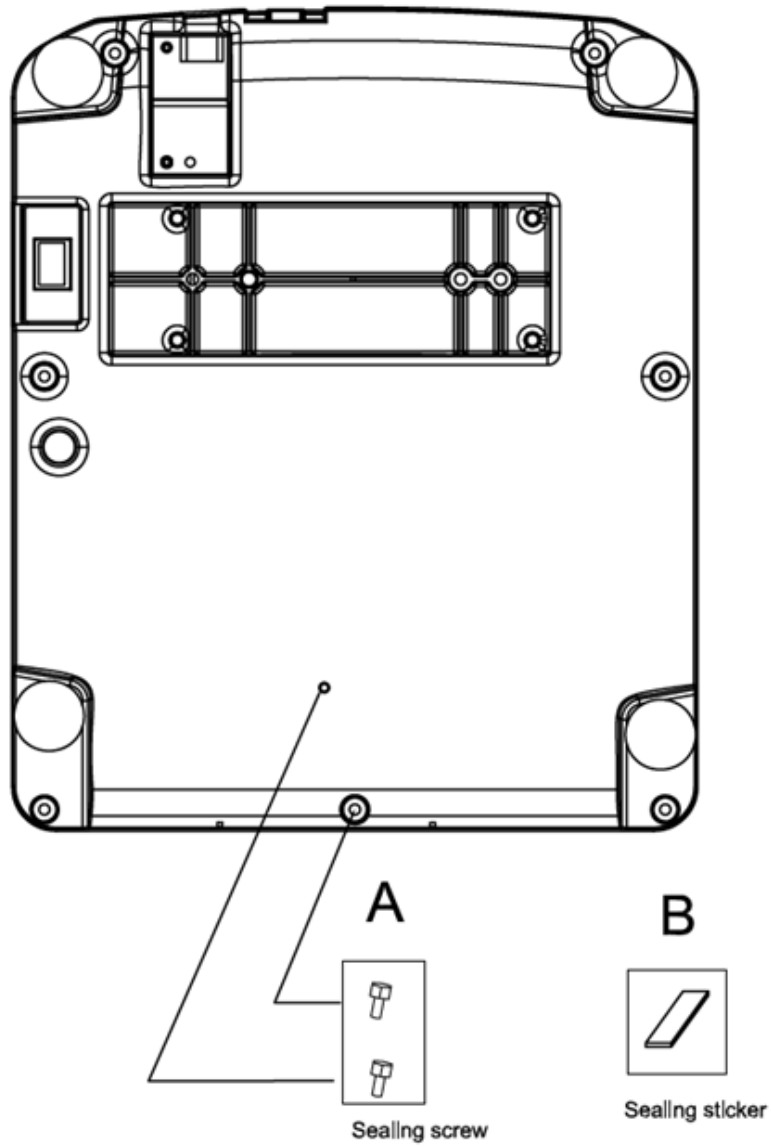

Typical Sealing Arrangement

~ End of Document ~