



Australian Government
Department of Industry,
Innovation and Science

National Measurement Institute

Certificate of Approval NMI 6/4D/382

Issued by the Chief Metrologist under Regulation 60
of the
National Measurement Regulations 1999

This is to certify that an approval for use for trade has been granted in respect of the instruments herein described.

CAS Model CL5200-P Weighing Instrument

submitted by CAS Corporation
19 Ganap-Ri, Gwangjoek-Myeon
Yangju-Si, Gyeonggi-Do
Republic of Korea

NOTE: This Certificate relates to the suitability of the pattern of the instrument for use for trade only in respect of its metrological characteristics. This Certificate does not constitute or imply any guarantee of compliance by the manufacturer or any other person with any requirements regarding safety.

This approval has been granted with reference to document NMI R 76, *Non-automatic weighing instruments, Parts 1 and 2*, dated October 2015.

This approval becomes subject to review on 1/01/21, and then every 5 years thereafter.

DOCUMENT HISTORY

Rev	Reason/Details	Date
0	Pattern & variants 1 & 2 approved – interim certificate issued	22/12/15
1	Pattern & variants 1 & 2 approved – certificate issued	19/07/16

CONDITIONS OF APPROVAL

General

Instruments purporting to comply with this approval shall be marked with pattern approval number 'NMI 6/4D/382' and only by persons authorised by the submitter.

It is the submitter's responsibility to ensure that all instruments marked with this approval number are constructed as described in the documentation lodged with the National Measurement Institute (NMI) and with the relevant Certificate of Approval and Technical Schedule. Failure to comply with this Condition may attract penalties under Section 19B of the National Measurement Act and may result in cancellation or withdrawal of the approval, in accordance with document NMI P 106.

The values of the performance criteria (maximum number of scale intervals etc.) applicable to an instrument incorporating the pattern approved herein shall be within the limits specified herein and in any approval documentation for the other components.

Auxiliary devices used with this instrument shall comply with the requirements of General Supplementary Certificate No S1/0B.

Special

Certain aspects of this instrument (in particular transaction record printing formats) are able to be configured by the user. Whilst NMI believes that acceptable formats can be achieved for typical basic sales modes, it is also possible for the instrument to be configured to produce unacceptable formats, and use of some formats may be inappropriate for different sales modes. It is the responsibility of the user to ensure that acceptable and appropriate formats are used in any particular situation.

Signed by a person authorised by the Chief Metrologist to exercise their powers under Regulation 60 of the *National Measurement Regulations 1999*.



Mario Zamora

TECHNICAL SCHEDULE No 6/4D/382

1. Description of Pattern **approved on 22/12/15**

A CAS model CL5200-P self-indicating multi-interval, class III non-automatic price-computing weighing instrument (Figure 1) with a verification scale interval of 0.001 kg up to 3 kg and with a verification scale interval of 0.002 kg from 3 kg up to 6 kg.

Instruments are fitted with one column-mounted seven segment customer display, and one operator display integral with main body of the instrument. An integral label/ticket printer is fitted (#).

Instruments have unit price to \$9999.99/kg, price to \$9999.99, a PLU facility, and may be fitted with output sockets (output interfacing capability) for the connection of peripheral and/or auxiliary devices.

The platter size of the instrument is 380 mm x 250 mm.

The instrument operates from mains AC power (100-240 V AC, 50/60 Hz). The software version of the instrument is AU V2.xx.x or AU V3.xx.x.

(#) Refer to the Special Condition of Approval.

1.1 Zero

Zero is automatically corrected to within $\pm 0.25e$ whenever power is applied and whenever the instrument comes to rest within $0.5e$ of zero.

The initial zero-setting device has a nominal range of not more than 20% of the maximum capacity of the instrument.

The instrument has a semi-automatic zero setting device with a nominal range of not more than 4% of the maximum capacity of the instrument.

1.2 Tare

A semi-automatic subtractive tare device and/or a non-automatic keyboard-entered pre-set subtractive tare device, each of up to 2.999 kg capacity, may be fitted.

Pre-set tare values may be associated with product look up (PLU) items.

A separate display of pre-set tare value is provided (marked PT). For both pre-set tare and semi-automatic tare, the tare value is displayed as a negative mass value when the load receptor is empty.

1.3 Levelling

The instrument is provided with adjustable feet and adjacent to the level indicator is a notice advising that the instrument must be level when in use.

1.4 Display Check

A display check is initiated whenever power is applied.

1.5 Networking

A number of instruments may be connected in a network to share common PLU data, and to accumulate and retrieve management information.

In addition, the network may be interfaced with a computer for the collection of management data, or the downloading of PLU data.

Note: The weighing and price computing functions of each weighing instrument in the network are independent, and the removal, repair or replacement of a particular weighing instrument does not necessitate re-verification of any other weighing instrument in the network.

1.6 Verification Provision

Provision is made for the application of a verification mark.

1.7 Sealing Provision

Provision is made for access to the 'calibration switch' (which is located below a cover plate underneath the platter and its support plate) to be sealed as shown in Figure 2. Sealing may be by either a lead and wire type seal or destructible adhesive label.

1.8 Descriptive Markings

Instruments carry the following markings:

Manufacturer's mark, or name written in full	CAS, Korea
Name or mark of manufacturer's agent
Indication of accuracy class	Ⓜ
Pattern approval mark for the instrument	NMI 6/4D/382
Maximum capacity	Max..... g or kg #1
Minimum capacity	Min..... g or kg #1
Verification scale interval	e = g or kg #1
Maximum subtractive tare	T = - g or kg #2
Serial number of the instrument

#1 These markings are also shown near the display of the result if they are not already located there.

#2 This marking is required if *T* is not equal to *Max*.

1.9 Printing Tickets and Labels

The Instrument has a printer for printing ticket or label. The instrument should prevent printing of label under minimum capacity when the instrument is used for prepack by weight purpose. The printing function of the instrument should comply with requirements of NMI R76-1 and NMI S1/0B, in particularly the print format and the height of characters which relating to measurement and metrological functions.

2. Description of Variant 1

approved on 22/12/15

The pattern with different capacities is listed in the Table 1 below. Note: the metrological characteristics in **bold** font are for the pattern.

TABLE 1

	CL5200-P					
Max. capacity (kg)	3/6	6	6/15	15	15/30	30
Min. capacity (g)	20	40	40	100	100	200
Verification interval, e (g)	1 / 2	2	2 / 5	5	5 / 10	10
Tare ≤ (kg)	- 2.999	- 6	- 5.998	- 15	- 14.995	- 30
E _{max} (kg)	6	6	15	15	30	30

3. Description of Variant 2

approved on 22/12/15

CAS model CL5200-B has similar metrological characteristics and functions as the pattern and variant 1. The difference is the CL5200-B has a customer display attached to the main body of the instrument as shown in Figure 3.

TEST PROCEDURE No 6/4D/382

Instruments shall be tested in accordance with any relevant tests specified in the National Instrument Test Procedures.

The instrument shall not be adjusted to anything other than as close as practical to zero error, even when these values are within the maximum permissible errors.

Maximum Permissible Errors

The maximum permissible errors are specified in Schedule 1 of the *National Trade Measurement Regulations 2009*.

For multi-interval instruments with verification scale intervals of e_1 , e_2 ..., apply e_1 for zero adjustment, and maximum permissible errors apply e_1 , e_2 ..., as applicable for the load.

FIGURE 6/4D/382 – 1



CAS Model CL5200-P Weighing Instrument (pattern)

FIGURE 6/4D/382 – 2

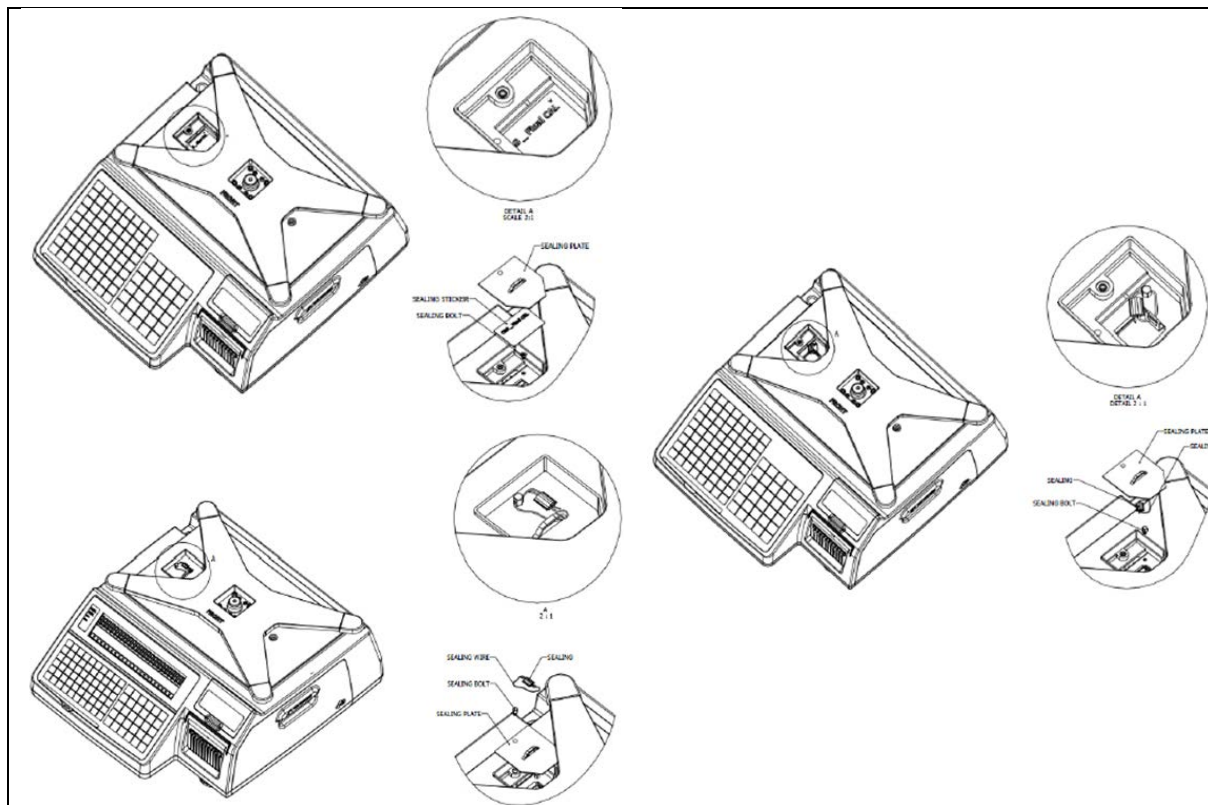

Sealing of Calibration Access

FIGURE 6/4D/382 – 3



CAS Model CL5200-B Weighing Instrument (variant 2)

~ End of Document ~