



Australian Government
Department of Industry,
Innovation and Science

National Measurement Institute

Certificate of Approval

NMI 6/4C/267A

Issued by the Chief Metrologist under Regulation 60
of the
National Measurement Regulations 1999

This is to certify that an approval for use for trade has been granted in respect of the instruments herein described.

Teraoka Model Digi DS-676 Weighing Instrument

submitted by W W Wedderburn Pty Ltd
101 Williamson Road
Ingleburn NSW 2565.

NOTE: This Certificate relates to the suitability of the pattern of the instrument for use for trade only in respect of its metrological characteristics. This Certificate does not constitute or imply any guarantee of compliance by the manufacturer or any other person with any requirements regarding safety.

This approval has been granted with reference to document NMI R 76, *Non-automatic weighing instruments, Parts 1 and 2*, dated July 2004.

This approval becomes subject to review on 1/06/22, and then every 5 years thereafter.

DOCUMENT HISTORY

Rev	Reason/Details	Date
0	Pattern & variants 1 to 3 approved – certificate issued	15/05/17

CONDITIONS OF APPROVAL

General

Instruments purporting to comply with this approval shall be marked with pattern approval number 'NMI 6/4C/267A' and only by persons authorised by the submittor.

It is the submittor's responsibility to ensure that all instruments marked with this approval number are constructed as described in the documentation lodged with the National Measurement Institute (NMI) and with the relevant Certificate of Approval and Technical Schedule. Failure to comply with this Condition may attract penalties under Section 19B of the National Measurement Act and may result in cancellation or withdrawal of the approval, in accordance with document NMI P 106.

The National Measurement Institute reserves the right to examine any instrument or component of an instrument purporting to comply with this approval.

Auxiliary devices used with this instrument shall comply with the requirements of General Supplementary Certificate No S1/0B.

Signed by a person authorised by the Chief Metrologist to exercise their powers under Regulation 60 of the *National Measurement Regulations 1999*.



Dr A Rawlinson

TECHNICAL SCHEDULE No 6/4C/267A

1. Description of Pattern

approved on 15/05/17

A Teraoka model Digi DS-676 class III multi-interval self-indicating non-automatic weighing instrument (Figure 1 and Table 1) with a verification scale interval e_1 of 0.002 kg up to 6 kg and with a verification scale interval e_2 of 0.005 kg from 6 kg up to 15 kg.

Instruments are provided with an LCD type display for the operator, and may also be provided with a second display integrated into the body of the instrument (as shown in Figure 1b). Where only an operator display is provided instruments shall be marked 'NOT FOR TRADING DIRECT WITH THE PUBLIC' (or similar wording).

Instruments are fitted with a load receptor as shown in Figure 1 which may also have a large platter overlay of up to 300 x 225 mm as shown in Figure 2.

Power for the model Digi DS-676 instrument may be supplied by:

- 4 x C size dry battery; or
- an AC/DC adapter (DC 6 V to 9 V).

Note: The AC/DC mains adaptor supplied for the instrument was an I.T.E. model 3A-066WP06 (6 V DC, 1 A) adaptor – the submitter should be consulted regarding the acceptability of alternative power supply units.

1.1 Zero

The initial zero-setting device has a nominal range of not more than 20% of the maximum capacity of the instrument.

The instrument has a semi-automatic zero-setting device with a nominal range of not more than 4% of the maximum capacity of the instrument.

A zero-tracking device may be fitted.

1.2 Tare

A semi-automatic subtractive tare device of up to 5.998 kg may be fitted.

1.3 Levelling

The instrument is provided with adjustable feet and a level indicator.

1.4 Display Check

A display check is initiated whenever power is applied.

1.5 Verification Provision

Provision is made for the application of a verification mark.

1.6 Sealing Provision

Provision is made for access to the calibration switch underneath the instrument to be sealed by applying a lead and wire or a destructible adhesive label (or similar) seal as shown in Figure 3.

1.7 Descriptive Markings and Notices

(a) Instruments carry the following markings:

Manufacturer's mark, or name written in full	Teraoka
Name or mark of manufacturer's agent	WEDDERBURN
Indication of accuracy class	Ⓜ
Pattern approval mark for the instrument	NMI 6/4C/267A
Maximum capacity	<i>Max</i>/..... g or kg #1
Minimum capacity	<i>Min</i> g or kg #1
Verification scale interval	<i>e</i> =/..... g or kg #1
Maximum subtractive tare	<i>T</i> = - g or kg #2
Serial number of the instrument

#1 These markings are also shown near the display of the result if they are not already located there. For single interval instruments (see variants) there is only one range therefore only one value of maximum capacity and verification scale interval to be marked.

#2 This marking is required if *T* is not equal to *Max*.

(b) Where only an operator display is provided instruments shall be marked 'NOT FOR TRADING DIRECT WITH THE PUBLIC' (or similar wording).

2. Description of Variant 1 approved on 15/05/17

The Digi DS-676SS series of multi-interval instruments which have the features of the pattern but have a metal housing (Figure 4).

3. Description of Variant 2 approved on 15/05/17

The Digi DS-676 and DS-676SS series of multi-interval instruments in various capacities as listed in Table 1.

TABLE 1 – Approved Multi-interval Instruments

Note: The bold letters indicate the specifications of the pattern.

Maximum Capacity (<i>Max</i> ₁ / <i>Max</i> ₂)	Verification Scale Interval (<i>e</i> ₁ , <i>e</i> ₂)	Maximum Subtractive Tare Capacity (<i>T</i> = - ...)	Load Cell Capacity
1.5/3 kg	0.0005/0.001 kg	1.4995 kg	4.5 kg
3/6 kg	0.001/0.002 kg	2.999 kg	9 kg
6/15 kg	0.002/0.005 kg	5.998 kg	22.5 kg
15/30 kg	0.005/0.01 kg	14.995 kg	45 kg

4. Description of Variant 3

approved on 15/05/17

The Digi DS-676 and DS-676SS series of single interval instruments in various capacities as listed in Table 2.

TABLE 2 – Approved Single Interval Instruments

Maximum Capacity (<i>Max</i>)	Verification Scale Interval (<i>e</i>)	Maximum Subtractive Tare Capacity (<i>T = - ...</i>)	Load Cell Capacity
1.5 kg	0.0005 kg	0.75 kg	2.3 kg
3 kg	0.0005 kg	1.5 kg	4.5 kg
3 kg	0.001 kg	1.5 kg	4.5 kg
6 kg	0.001 kg	3 kg	9 kg
6 kg	0.002 kg	3 kg	9 kg
15 kg	0.002 kg	7.5 kg	22.5 kg
15 kg	0.005 kg	7.5 kg	22.5 kg
30 kg	0.005 kg	15 kg	45 kg
30 kg	0.01 kg	15 kg	45 kg

TEST PROCEDURE No 6/4C/267A

Instruments shall be tested in accordance with any relevant tests specified in the National Instrument Test Procedures.

The instrument shall not be adjusted to anything other than as close as practical to zero error, even when these values are within the maximum permissible errors.

Maximum Permissible Errors

The maximum permissible errors are specified in Schedule 1 of the *National Trade Measurement Regulations 2009*.

Tests

For multi-interval instruments with verification scale intervals of $e_1, e_2 \dots$, apply e_1 for zero adjustment, and maximum permissible errors apply $e_1, e_2 \dots$, as applicable for the load.

FIGURE 6/4C/267A – 1



(a) Showing Operator's Display



(b) Showing Customers' Display

Teraoka Model Digi DS-676 Weighing Instrument
(with standard load receptor)

FIGURE 6/4C/267A – 2



Teraoka Model Digi DS-676 Weighing Instrument
(with large platter overlay)

FIGURE 6/4C/267A – 3

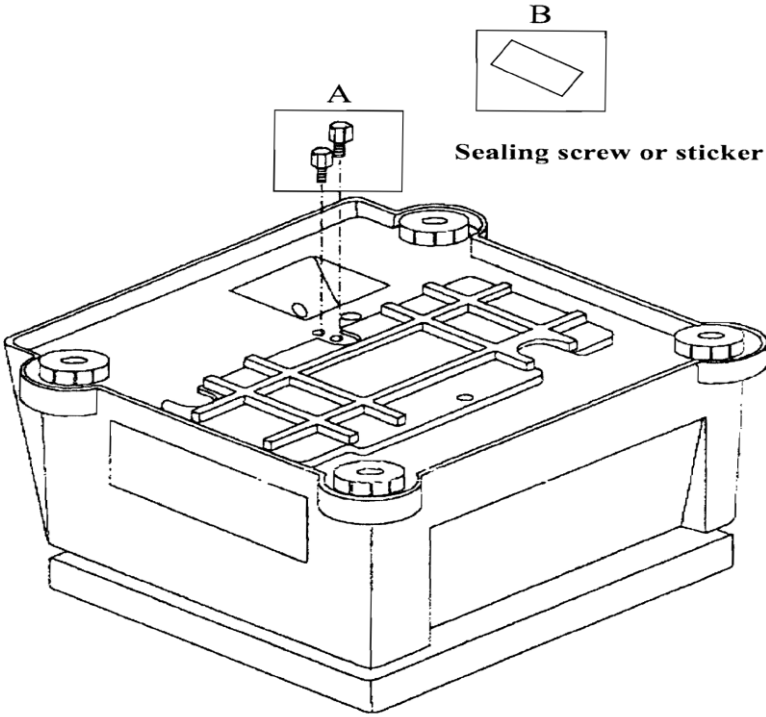

Teraoka Model Digi DS-676 – Typical Sealing Arrangements

FIGURE 6/4C/267A – 4



Teraoka Model Digi DS-676SS Weighing Instrument

~ End of Document ~