



Australian Government
**Department of Industry, Science,
Energy and Resources**

National Measurement Institute

36 Bradfield Road, West Lindfield NSW 2070

Certificate of Approval NMI 6/14D/11B

Issued by the Chief Metrologist under Regulation 60
of the
National Measurement Regulations 1999

This is to certify that an approval for use for trade has been granted in respect of the instruments herein described.

Ramsey Model 10-14-4 Belt Weighing Instrument

submitted by Thermo Gamma-Metrics Pty Ltd
(T/A Thermo Fisher Scientific)
18 Butler Boulevard
Burbridge Business Park
Adelaide Airport SA 5950.

NOTE: This Certificate relates to the suitability of the pattern of the instrument for use for trade only in respect of its metrological characteristics. This Certificate does not constitute or imply any guarantee of compliance by the manufacturer or any other person with any requirements regarding safety.

This approval has been granted with reference to document NMI R 50, *Continuous totalising automatic weighing instruments (belt weighers), Parts 1 and 2*, dated July 2004.

This approval becomes subject to review on **1/01/22**, and then every 5 years thereafter.

DOCUMENT HISTORY

Rev	Reason/Details	Date
0	Pattern & variants 1 to 7 approved – interim certificate issued	16/12/99
1	Pattern & variants 1 to 7 approved – certificate issued	20/03/00
2	Variants 8 and 9 approved – interim certificated issued	1/06/00
3	Variants 8 and 9 approved – certificated issued	16/08/00
4	Pattern amended (submitor name & address, & clause 1.1) – notification of change issued	28/06/01
5	Variant 10 provisionally approved – interim certificate issued	12/11/02
6	Variant 7 cancelled – variants 10 & 12 approved – variant 11 provisionally approved – certificate issued	4/06/03

Document History (cont...)

Rev	Reason/Details	Date
7	Test procedure amended (item 3 in 'Calculations') – notification of change issued	4/08/05
8	Pattern & variants amended (submitter address, instrument & load cell branding) & reviewed – notification of change issued	3/08/06
9	Variant 13 approved – certificate issued	14/05/07
10	Variants 14 and 15 provisionally approved – interim certificate issued	17/03/09
11	Pattern & variants amended (submitter name, 2 nd instrument & address for variant 13 – notification of change issued	13/07/09
12	Variant 14 cancelled – variant 15 approved – certificate issued	11/08/10
13	Pattern & variants 1 to 15 amended (submitter address) & reviewed – notification of change issued	17/02/11
14	Pattern & variants 1 to 15 updated & reviewed – certificate issued	19/01/17
15	Variant 16 provisionally approved – interim certificate issued	30/08/19
16	Variant 16 amended (class) – certificate issued	03/09/19
17	Variants 16 & 17 approved – certificate issued	18/02/20

CONDITIONS OF APPROVAL

General

Instruments purporting to comply with this approval shall be marked with pattern approval number 'NMI (or NSC) 6/14D/11B' and only by persons authorised by the submitter.

Instruments purporting to comply with this approval and currently marked 'NMI (or NSC) P6/14D/11B' may be re-marked 'NMI (or NSC) 6/14D/11B' but only by persons authorised by the submitter.

It is the submitter's responsibility to ensure that all instruments marked with this approval number are constructed as described in the documentation lodged with the National Measurement Institute (NMI) and with the relevant Certificate of Approval and Technical Schedule. Failure to comply with this Condition may attract penalties under Section 19B of the National Measurement Act and may result in cancellation or withdrawal of the approval, in accordance with document NMI P 106.

Auxiliary devices used with this instrument shall comply with the requirements of General Supplementary Certificates No S1/0/A or No S1/0B.

This approval shall NOT be used in conjunction with General Certificate No 6B/0.

Special: For the pattern and all variants

Instruments must comply with all calculations provided in the Test Procedure No 6/14D/11B attached herein.

Special: For provisional variant 11

NMI may attend and carry out in-situ testing in conjunction with the verification testing.

The submitter shall provide NMI with copies of test results from the initial verification and all subsequent tests.

In the event of unsatisfactory performance or of suitable test results not being received by NMI, the approval may be withdrawn.

Special: For variant 13

This approval is limited to two (2) instruments located at (a) the Antiene Coal Unloader (Macquarie Generation), Muswellbrook NSW, and (b) Delta Electricity, Mandalong 414 Conveyor, Wyee NSW.

Signed by a person authorised by the Chief Metrologist to exercise their powers under Regulation 60 of the *National Measurement Regulations 1999*.



Darryl Hines
Manager
Policy and Regulatory
Services

TECHNICAL SCHEDULE No 6/14D/11B

1. Description of Pattern

approved on 16/12/99

The pattern is a Ramsey model 10-14-4 class 1 belt conveyor weigher of 1000 t/h maximum flow rate, approved for use over a flow rate range of 20% to 100% of maximum flow rate. The instrument is approved with a weigh length of 4.8 m and a belt speed of 3.6 m.s⁻¹. May also be known as Thermo Ramsey instruments.

The instrument may be fitted with output sockets for the connection of auxiliary and/or peripheral equipment. Means shall be provided to ensure that the conveyor cannot move in the reverse direction.

1.1 Basework (Figure 1)

The model 10-14 weigh frame has no less than 2 idler rollers mounted on a frame which is suspended from two beams which span the conveyor stringers.

Four Revere (or Revere Transducers) model BSP-A3-1K-30P5 load cells of 450 kg capacity mounted in tension, connect the support beams to the floating weigh frame, which is stabilised by four tie rods.

1.2 Belt Speed Sensor

A Ramsey model 60-12 digital speed sensor is used.

1.3 Computing and Totalising Unit

A Ramsey Micro-tech 2000 model 2101 integrator (Figure 2) is used.

1.3.1 Non-resettable totaliser

The instrument is provided with an additional remote indicator which is able to display the accumulated total during a power failure.

1.3.2 Sealing

Access to the calibration facilities of the integrator is secured by a password, and evidence of alteration of the calibration is provided by an audit trail.

(i) Password

The following procedure can be used to ensure that password protection has been enabled:

- (a) Select Main Menu 3.
- (b) Select the PROT option.
- (c) Select NONE.
- (d) The integrator should display
'PROTECTION LEVEL PROTECTED - PASSWORD ENTER'; this indicates that a password is required to access the calibration feature.
- (e) Press the MENU key to return to the main menus.

(ii) Evidence of calibration alteration (Audit Trail)

The audit trail records each change to the calibration and set-up parameters of the instrument, including the old and new values (indicated by O and N). Access to the audit trail may be obtained by the following procedure:

- (a) Select Main Menu 6 (press the Menu key until this appears).
- (b) Select Audit Trail.
- (c) Press the down arrow key twice and wait for the audit trail to appear.
- (d) The integrator should display "TRAIL EVENT No ###". This number is incremented whenever calibration or set-up parameters are changed.

The TRAIL EVENT No shown should be recorded onto the calibration/verification label to indicate the value when calibration/verification was carried out.

The TRAIL EVENT No recorded on the calibration/verification label, and that indicated in step (d) above should be the same. Any discrepancy indicates that calibration data had been altered.

Earlier events in the audit trail may be examined by continuing to press the down arrow key, and the instrument may be returned to the normal operational mode by pressing the RUN key.

1.4 Verification Provision

Provision is made for a verification mark to be applied.

1.5 Descriptive Markings and Notices

Instruments shall be clearly and permanently marked on one or more permanently attached nameplates with the following information:

Manufacturer's mark, or name written in full
Indication of accuracy class	class 1 or class 2
Type designation (model number) of the instrument
Serial number of the instrument
Pattern approval mark for the instrument	NMI (or NSC) No 6/14D/11B
Maximum flow rate	$Q_{max} = \dots \text{ kg/h or t/h}$
Minimum flow rate	$Q_{min} = \dots \text{ kg/h or t/h}$
Minimum totalised load	$\Sigma_{min} = \dots \text{ kg or t}$
Maximum capacity of the weighing unit	Max =..... kg or t
Totalisation scale interval	d =..... kg or t
Belt speed	v =..... m/s
Weigh length	L = m
Temperature range	-10°C / 40°C
Designation of product(s) to be weighed (if not fixed by installation conditions).	

In addition to the above markings the instrument shall bear the inscription:

'Zero testing shall have a duration of at least ... revolutions'.

The number of revolutions in this statement shall be a whole number of revolutions (at least one) and of a duration as close as possible to 3 minutes.

2. Description of Variant 1 **approved on 16/12/99**

The pattern and variants as class 2 belt conveyor weighing instruments.

3. Description of Variant 2 **approved on 16/12/99**

A model 10-17-2 instrument with a model 10-17 weigh frame with a weigh length of up to 4 m (Figure 3). Two idler rollers are mounted on a frame which has a fulcrum at one end consisting of two rubber bushes and is supported between the idlers by two Revere (or Revere Transducers) model BSP-A3-250-30P5 load cells of 120 kg capacity.

For the purposes of the calculations included in this technical schedule, the lever ratio r may be taken as:

$$r = \frac{2D_c}{D_{11} + D_{12}}$$

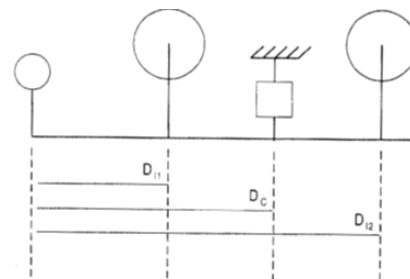

4. Description of Variant 3 **approved on 16/12/99**

A model 10-17-2/2 instrument with a model 10-17-2/2 weigh frame with a weigh length of up to 4 m (Figure 4). Two idler rollers are mounted on a frame which has a fulcrum at one end consisting of two rubber bushes and is supported by a single Revere (or Revere Transducers) BSP-A3-250-30P5 load cell of 120 kg capacity located as shown in Figure 5.

For the purposes of the calculations included in this technical schedule, the lever ratio r may be taken as:

$$r = \frac{2D_c}{D_{11} + D_{12}}$$

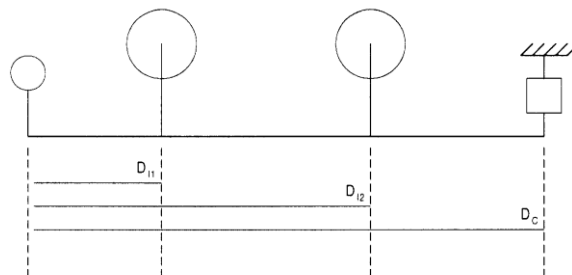

5. Description of Variant 4 **approved on 16/12/99**

A model 10-14AVE instrument which uses a model 10-14AVE weigh frame (Figure 6). The weighframe is a 4-point suspended unit supporting between 3 and 20 idler rollers. The 4-point suspension comprises four Commission approved tension type load cells.

6. Description of Variant 5 **approved on 16/12/99**

A system with a Ramsey model 2301-D digitiser and Ramsey model 2301 integrator (Figure 7).

The load cells and/or speed sensor may be connected to the model 2301-D digitiser, which communicates information from these sensors to the model 2301 integrator which calculates and displays the weighing result.

Provision for sealing and a non-resettable totaliser are as described for the pattern (model 2101 integrator).

7. Description of Variant 6 **approved on 16/12/99**

The pattern or variants with various maximum and minimum flow rates, with weighframes of various capacities using NMI-approved load cells of various capacities.

The instruments may be of various weigh lengths, and with various belt speeds.

The minimum flow rate shall be not less than 20% of the maximum flow rate.

8. Description of Variant 7 **approved on 16/12/99**
cancelled on 4/06/03

The pattern or variants with Revere (or Revere Transducers) BSP-A3-*-30P5 series load cells of models and capacities as listed in Table 1 (where -* is replaced by the characters listed).

NOTE: All the figures in the table are in kilograms.

TABLE 1

Model BSP-A3-*-30P5; for -* read:	-250-	-500-	-1K-	-2.5K
2.5K Maximum capacity - E_{max}	120	227	450	1134
Minimum value of verification scale interval - V_{min}	0.031	0.035	0.091	0.15
Maximum number of verification scale intervals - n_{max}	1500	500	1000	2000

9. Description of Variant 8 **approved on 01/06/00**

A model 10-17-4/2 instrument with a weigh length of up to 6 m (Figure 8). Two idler rollers are mounted on a frame which has a fulcrum at one end consisting of two rubber bushes and is supported by two load cells mounted and located as shown in Figures 9 and 10. Another two idlers are mounted on a similar frame which also has a fulcrum at one end consisting of two rubber bushes; forces from this frame are transferred to the other frame (and hence to the load cells) by connection of the two frames using two flexure plates, one at each side of the frames.

Note that (with the exception of the load cell location) both frames are symmetrical about the location of the flexures.

For the purposes of the calculations included in this technical schedule, the lever ratio r may be taken as:

$$r = \frac{2D_c}{D_{11} + D_{12}}$$

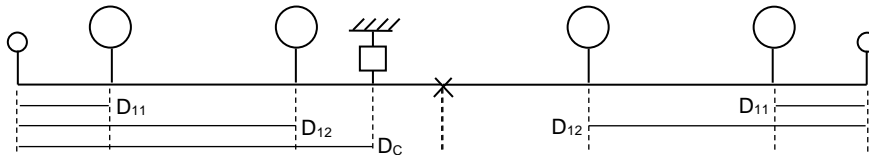

10. Description of Variant 9

approved on 01/06/00

A system with the basework being that of a Toledo model 8172 belt conveyor weigher (Approval NSC 6/14D/12). This variant is not for the construction of new baseworks of this type, but is intended to allow replacement of the computing and totalising unit of 6/14D/12 (which has been cancelled) with the computing and totalising units of this approval.

For the purposes of the calculations included in this technical schedule, the lever ratio r must be determined individually for each installation, and must be advised to NMI.

Instruments purporting to comply with this variant shall be marked NMI (or NSC) No 6/14D/11B in addition to the approval number of the basework already marked on the instrument.

11. Description of Variant 10

**provisionally approved 12/11/02
approved on 4/06/03**

Ramsey series 10-14 and 10-17-4 series belt conveyor weighing instruments (the pattern and variant 8 respectively) fitted with the model 2301-D digitiser and the model 2301 integrator (as described in variant 5) as class 0.5 belt weighers.

12. Description of Variant 11

provisionally approved on 4/06/03

Ramsey series 10-17-2 and 10-17-2/2 series belt conveyor weighing instruments (variants 2 and 3 respectively) fitted with the model 2301-D digitiser and the model 2301 integrator (as described in variant 5) as class 0.5 belt weighers.

13. Description of Variant 12

approved on 4/06/03

The pattern or variants with Revere (or Revere Transducers) BSP series load cells of capacities and with other specifications as listed in the documentation of approval NSC No S385.

14. Description of Variant 13

approved on 14/05/07

A system with the basework being that of a Schenck model 3BMP-16 class 0.5 belt weighing instrument (as described in the documentation of approval NMI 6/14D/15).

This approval is limited to two instruments located at (a) the Antiene Coal Unloader (Macquarie Generation), Muswellbrook NSW, and (b) Delta Electricity, Mandalong 414 Conveyor, Wyee NSW.

For the purposes of the calculations included elsewhere in this approval, the lever ratio ' r ' is equal to '1'.

Instruments purporting to comply with this variant shall be marked '6/14D/11B' in addition to the approval number of the basework already marked on the instrument.

15. Description of Variant 14 **provisionally approved on 17/03/09**
cancelled on 11/08/10

Note: Variant 14 was provisionally approved by Interim Certificate No 6/14D/11B Variation No 3 issued 17 March 2009 (for the Ramsey 10-14 series belt conveyor weighing instruments fitted with the model 2101 integrator as class **0.5** belt conveyor weighing instruments).

However, the provisional approval has now been **cancelled**. Any instrument purporting to comply with this provisional approval must either be amended to comply with the pattern or another variant, or must be removed from use for trade.

16. Description of Variant 15 **provisionally approved on 17/03/09**
approved on 11/08/10

The pattern or variants using MTL model MTL7761Pac or model MTL7766Pac barrier devices.

Note: These devices are installed where safety requirements warrant their use, however this Certificate does not constitute or imply any guarantee of compliance by the manufacturer or any other person with any requirements regarding safety.

17. Description of Variant 16 **provisionally approved on 30/08/19**
amended on 03/09/19
approved on 18/02/20

Ramsey 10-14 series belt conveyor weighing instruments fitted with a Thermo Scientific Ramsey Micro-tech model MT9301F integrator (Figure 10a) with a Thermo Scientific Ramsey Micro-tech model 9301D digitiser (Figure 10b) as class 0.5, 1 or 2 belt conveyor weighing instruments.

The integrator/totaliser may be fitted with output sockets (output interfacing capability) for the connection of auxiliary and/or peripheral devices.

The load cells and/or speed sensor may be connected to the model 9301-D digitiser, which communicates information from these sensors to the model MT9301F integrator which calculates and displays the weighing result.

Instruments use compatible NMI approved load cells which must comply with all calculations provided in Technical Schedule No 6/14D/11B.

17.1 Non-resettable totaliser

The instrument is provided with an additional remote indicator which is able to display the accumulated total during a power failure.

17.2 Sealing

Access to the calibration facilities of the integrator is secured by a password, and evidence of alteration of the calibration is provided by an audit trail.

The audit trail records each change to the calibration and set-up parameters of the instrument, including the old and new values (indicated by O and N). Access to the audit trail may be obtained by the following procedure:

- (a) Select Main Menu 6 (press the 'MENU' key until this appears).
- (b) Select Audit Trail.
- (c) Press the red down arrow key and wait for the audit trail to appear.

- (d) The integrator should display “TRAIL EVENT No ###”. This number is incremented whenever calibration or set-up parameters are changed.

The TRAIL EVENT No shown should be recorded onto a destructible adhesive label attached to the instrument to indicate the value when verification was carried out.

The TRAIL EVENT No recorded on the label, and that indicated in step (d) above should be the same. Any discrepancy indicates that calibration data had been altered.

Earlier events in the audit trail may be examined by selecting ‘<’ or ‘>’, and the instrument may be returned to the normal operational mode by pressing the ‘RUN’ key.

17.3 Software

The MT9301F integrator software is designated version 144.00.01.00 and the 9301D digitiser software is designated version Rev A3.6.

The instructions for accessing the software version are as follows (starting from the normal weighing mode):

- (a) Select Main Menu 3 (press the ‘MENU’ key until this appears).
- (b) Press the ‘DIAG’ key.
- (c) Press the red down arrow key 7 times. The main software version is displayed.
- (d) Press the red down arrow key once. The digitiser software version is displayed.

18. Description of Variant 17

approved on 18/02/20

Variants 2, 3 and 8 fitted with a Thermo Scientific Ramsey Micro-tech model MT9301F integrator (Figure 10a) with a Thermo Scientific Ramsey Micro-tech model 9301D digitiser (Figure 10b) as class 0.5, 1 or 2 belt conveyor weighing instruments as described in variant 16.

TEST PROCEDURE No 6/14D/11B

Instruments shall be tested in accordance with any relevant tests specified in the National Instrument Test Procedures.

Maximum Permissible Errors

The maximum permissible errors are specified in Schedule 1 of the *National Trade Measurement Regulations 2009*.

CALCULATIONS

1. Load cell(s) – number of verification intervals

Class 0.5: $n_{max} \geq 1500$

Class 1: $n_{max} \geq 1000$

Class 2: $n_{max} \geq 500$

2. Load cell(s) – capacity

$$E_{max} \geq \frac{Max + DL}{N \cdot r}$$

3. Temperature effect on the minimum load on the load cell(s)

Class 0.5: $v_{min} \leq \frac{0.00025 \cdot Max}{r \cdot \sqrt{N}}$

Class 1: $v_{min} \leq \frac{0.0005 \cdot Max}{r \cdot \sqrt{N}}$

Class 2: $v_{min} \leq \frac{0.001 \cdot Max}{r \cdot \sqrt{N}}$

where:

E_{max} = Maximum capacity of the load cell(s)

Max = Capacity of the weighframe at maximum flow rate

$$= \frac{Q_{max} \cdot L}{V}$$

DL = Dead load of weighframe

N = Number of load cells supporting weighframe

r = Lever ratio ($r = 1$ if system does not use levers)

L = Weigh length

V = Belt speed

Q_{max} = Maximum flow rate

v_{min} = Minimum value of verification interval for the load cell(s)

n_{max} = Maximum number of verification intervals for the load cell(s)

FIGURE 6/14D/11B – 1



Ramsey Model 10-14-4 Weigh Frame

FIGURE 6/14D/11B – 2



Ramsey Micro-tech 2000 Model 2101 Integrator

FIGURE 6/14D/11B – 3

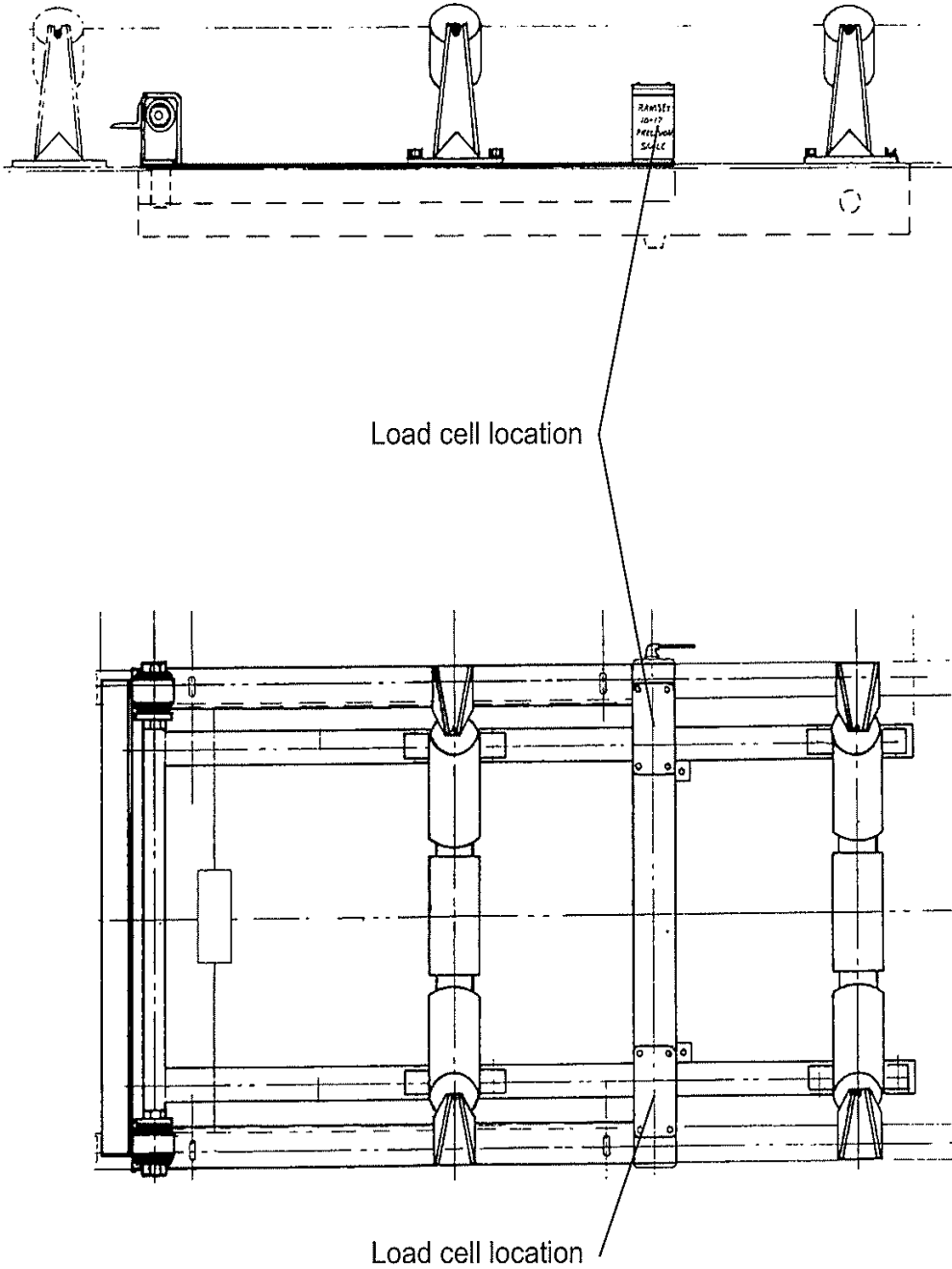

Model 10-17-2 Weigh Frame

FIGURE 6/14D/11B - 4

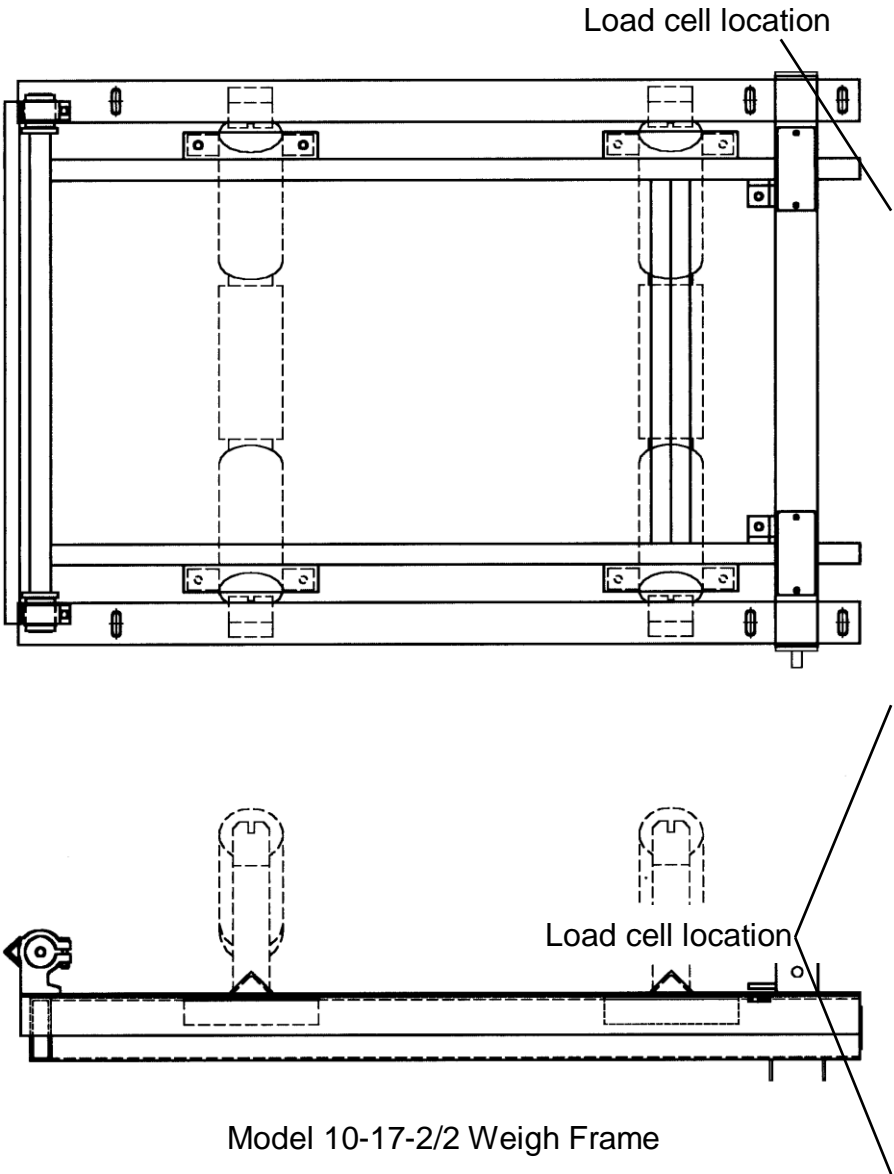

Model 10-17-2/2 Weigh Frame

FIGURE 6/14D/11B - 5

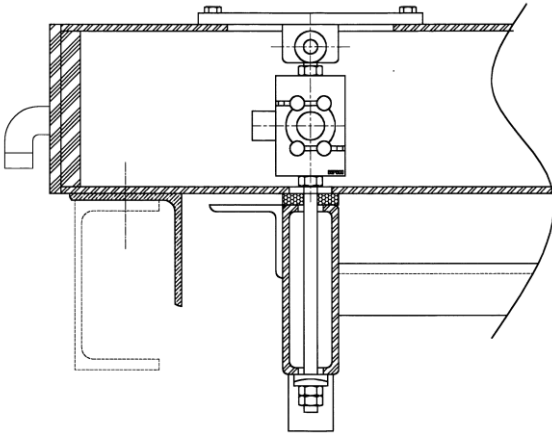

Load Cell Mounting for Model 10-17-2/2

FIGURE 6/14D/11B – 6

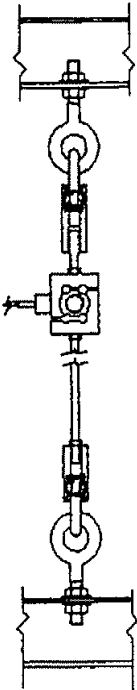
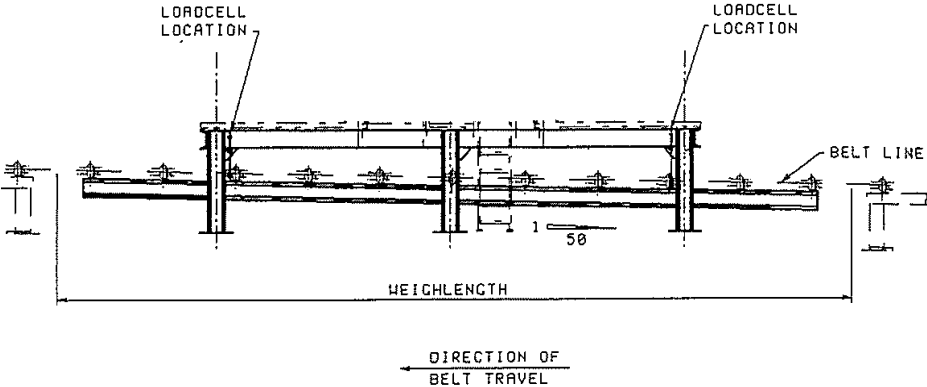

Model 10-14AVE Weigh Frame

FIGURE 6/14D/11B – 7



Model 2301-D Digitiser



Model 2301 Integrator

FIGURE 6/14D/11B – 8

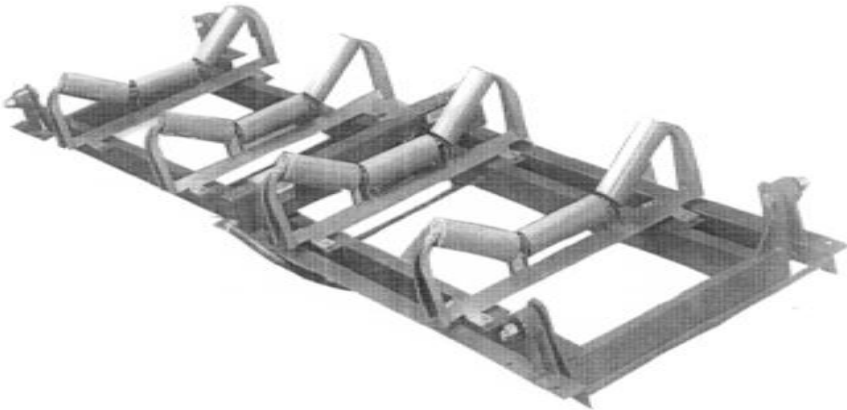

Ramsey Model 10-17-4/2 Weigh Frame

FIGURE 6/14D/11B – 9

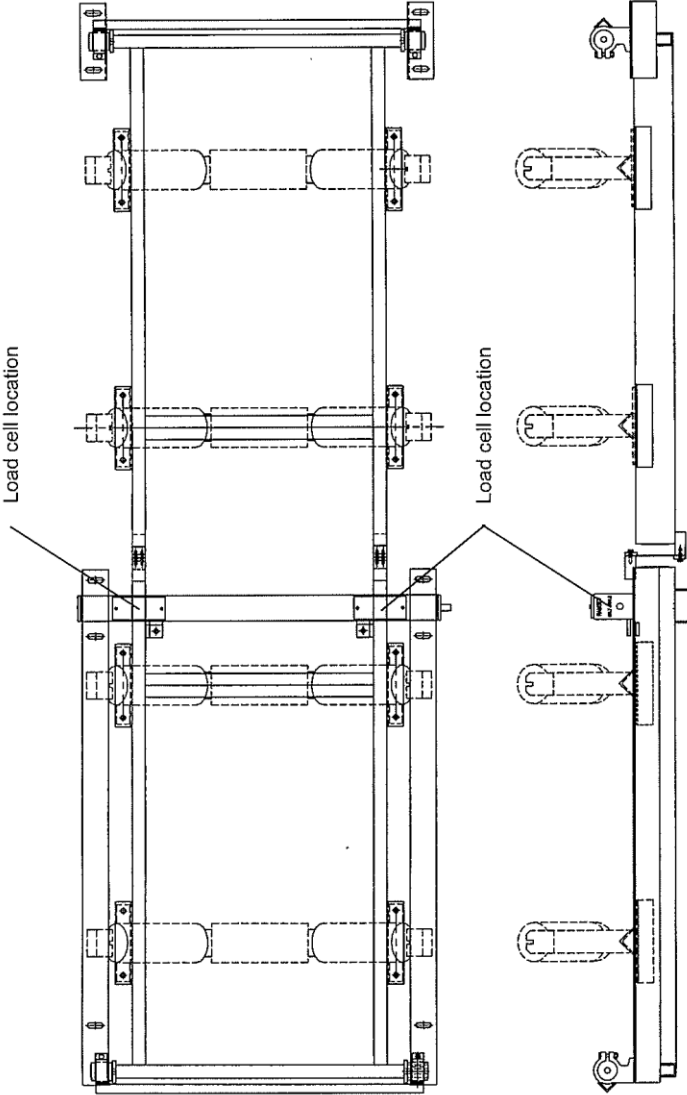

Ramsey Model 10-17-4/2 Weigh Frame

FIGURE 6/14D/11B – 10



(a) Model MT9301F Integrator



(b) Model 9301D Digitiser

~ End of Document ~