



NATIONAL STANDARDS COMMISSION

WEIGHTS & MEASURES (PATTERNS OF INSTRUMENTS) REGULATIONS

REGULATION 9

CERTIFICATE OF APPROVAL No 5/6B/49

This is to certify that an approval has been granted by the Commission that the pattern and variants of the

Pipeline/Loading Rack System with Tokheim 1400-30 Series Flowmeter

submitted by Gilbarco Aust. Ltd,
12 - 38 Talavera Road,
North Ryde, New South Wales, 2113,

are suitable for use for trade.

The approval of the pattern and variants is subject to review on or after 1/1/85.

All instruments purporting to comply with this approval shall be marked NSC No 5/6B/49.

Relevant drawings and specifications are lodged with the Commission.

Conditions of Approval

1. The maximum and minimum flow rates are 1325 L/min and 265 L/min.
2. When the difference between maximum and minimum flow rates, in normal conditions of use, exceeds 132 L/min, the maximum and minimum flow rates shall be marked on the data plate.

When the flow rate in normal conditions of use is within $\pm 5\%$ of a nominal flow rate, the nominal flow rate shall be marked on the data plate.
3. The instrument is not used for liquified gases.
4. The liquid for which the instrument is verified is marked on the data plate, namely petrol, kerosene, heating oil or distillate.
5. The system is designed so that gas cannot enter the meter.
6. Instruments are installed in the manner described in Technical Schedule No 5/6B/49.
7. The Commission reserves the right to inspect any installation incorporating a meter covered by this approval.

Signed

Executive Director

Descriptive Advice

Pattern: approved 5/8/81

- . A pipeline flowmeter system or a loading rack flowmeter system, with a Tokheim 1400-30 Series flowmeter.

Variants: approved 5/8/81

1. With Tokheim 1450-30 flowmeter.
2. With Tokheim 2415-30 flowmeter.
3. With Tokheim 2430-30 flowmeter.
4. Without ticket printer.
5. Without preset-control indicator and preset valve.
6. With rigid extension between the meter and indicator.
7. Without pulse transmitter.
8. Without flow-rate control valve.
9. Without swivel adaptor under indicator.
10. Without rate of flow tachometer.
11. Without mechanical drive housing.

Technical Schedule No 5/6B/49 dated 28/8/81 describes the pattern and variants 1 to 10.



NATIONAL STANDARDS COMMISSION

TECHNICAL SCHEDULE No 5/6B/49

Pattern: Pipeline/Loading Rack System with Tokheim 1400-30 Series Flowmeter

Submitter: Gilbarco Aust. Ltd,
12 - 38 Talavera Road,
North Ryde, New South Wales, 2113.

1. Description of Pattern

1.1 Pipeline flowmeter

Refer to Figure 1.

The system comprises:

- (a) Supply tank.
 - (b) Pump - mounted lower than the minimum height of the liquid in the supply tank; the supply pipe from the tank has a continuous fall to the pump; provision is made for a pressure gauge to be connected to the suction side of the pump; if the pump is not for the exclusive use of the flowmeter, the flow rate through the meter must stay within the appropriate flow rate range for all combinations of alternate uses of output from the pump.
 - (c) A non-return valve between the pump and the meter, or an arrangement of the components and the piping to keep the system full of liquid at all times.
 - * (d) Strainer.
 - (e) Tokheim 1400-30 flowmeter (Figure 3).
 - (f) One of the following combinations of assemblies:
 - (i) Indicator model VR1624.
 - (ii) Indicator model VR1624 with accumulative or zero-start ticket printer.
- The indicators and ticket printers are single-handle reset. A preset indicator model number VR7889 or VR1646 and preset-control valve may be fitted to the indicator with or without a ticket printer. The preset indicator is not approved for trade use.
- (g) Mechanical drive housing,
 - (h) Up to four pulse transmitters with interface to other accessory devices which are not in use for trade.
 - (i) A swivel adaptor fitted under the indicator.
 - (j) Flow rate control valve.
 - (k) Outlet-control valve located downstream of the meter with no intermediate outlet.

* The strainer is not a part of the measuring instrument examined and approved by the Commission.

- (1) Rate of flow tachometer.

1.2 Loading-rack Flowmeter System

This system is identical to the pipeline system except for the outlet which is replaced by one of the following:

- (a) Top-loading arrangement (Figure 2) - the highest point of the pipework forms a weir at a fixed level from which the delivery pipe drains to the outlet for all configurations of the loading arm whilst in operation; the outlet-control valve is installed at or upstream of the highest point and a syphon breaker is installed to ensure complete draining of the pipework downstream of the weir,

or

- (b) Bottom-loading arrangement - drybreak coupling located at the delivery point of the piping.

1.3 Features Common to Both Systems

1.3.1 Marking

The instrument data plate is marked with the following:

Manufacturer's name or mark
 Meter model
 Serial number
 NSC approval number in the form: NSC No 5/6B/49
 Maximum flow rate) (when operating over a range
 Minimum flow rate) of more than 132 L/min)
 Nominal flow rate) (when flow rate is within $\pm 5\%$ of nominal)
 Viscosity range or type of liquid for which the instrument is verified
 Minimum delivery

1.3.2 Sealing

- (a) The indicator, ticket printer, preset indicator and pulse transmitter are sealed by passing a sealing wire through the attachment-mounting bolts. The calibrator is sealed by the same wire or a separate wire terminating beneath a lead-stamping plug on the calibration-adjustment cover (Figures 4, 5 and 6).
- (b) The instrument data plate is sealed to the instrument by a lead-stamping plug or by threading the indicator-sealing wire through a hole in the data plate.
- (c) If the peripheral equipment is fitted, sealing is to be provided at the peripheral equipment plugs and sockets.

1.4 Minimum Delivery

The following minimum deliveries are applicable:

100 L with indicator only;
 200 L with zero-start printer and indicator;
 400 L with accumulative-start printer and indicator.

1.5 Variants

1.5.1 Variant 1 - with Tokheim 1450-30 flowmeter (Figure 7).

-
- 1.5.2 Variant 2 - with Tokheim 2415-30 flowmeter (Figure 8).
 - 1.5.3 Variant 3 - with Tokheim 2430-30 flowmeter (Figure 8).
 - 1.5.4 Variant 4 - without ticket printer.
 - 1.5.5 Variant 5 - without preset-control indicator and preset valve.
 - 1.5.6 Variant 6 - with rigid extension between the meter and indicator.
 - 1.5.7 Variant 7 - without pulse transmitter.
 - 1.5.8 Variant 8 - without flow rate control valve.
 - 1.5.9 Variant 9 - without swivel adaptor under indicator.
 - 1.5.10 Variant 10 - without rate of flow tachometer.
 - 1.5.11 Variant 11 - without mechanical drive housing.

TEST PROCEDURE No 5/6B/49

1. The instrument should be tested with the liquid for which it will be used and which is marked on the data plate.

The maximum permissible errors at verification are:

- (a) $\pm 0.3\%$ for all flow rates when operating over a flow range within the marked maximum and minimum flow rates, varying by more than 132 L/min.
 - (b) $\pm 0.15\%$ when operating at a flow rate, $\pm 5\%$ of nominal.
2. Test delivery - if the test delivery is less than ten times the minimum delivery, the reading error of the indicator or the rounding error of the ticket printer is minimised by completing the delivery at a graduation line.

FIGURE 5/6B/49 - 1

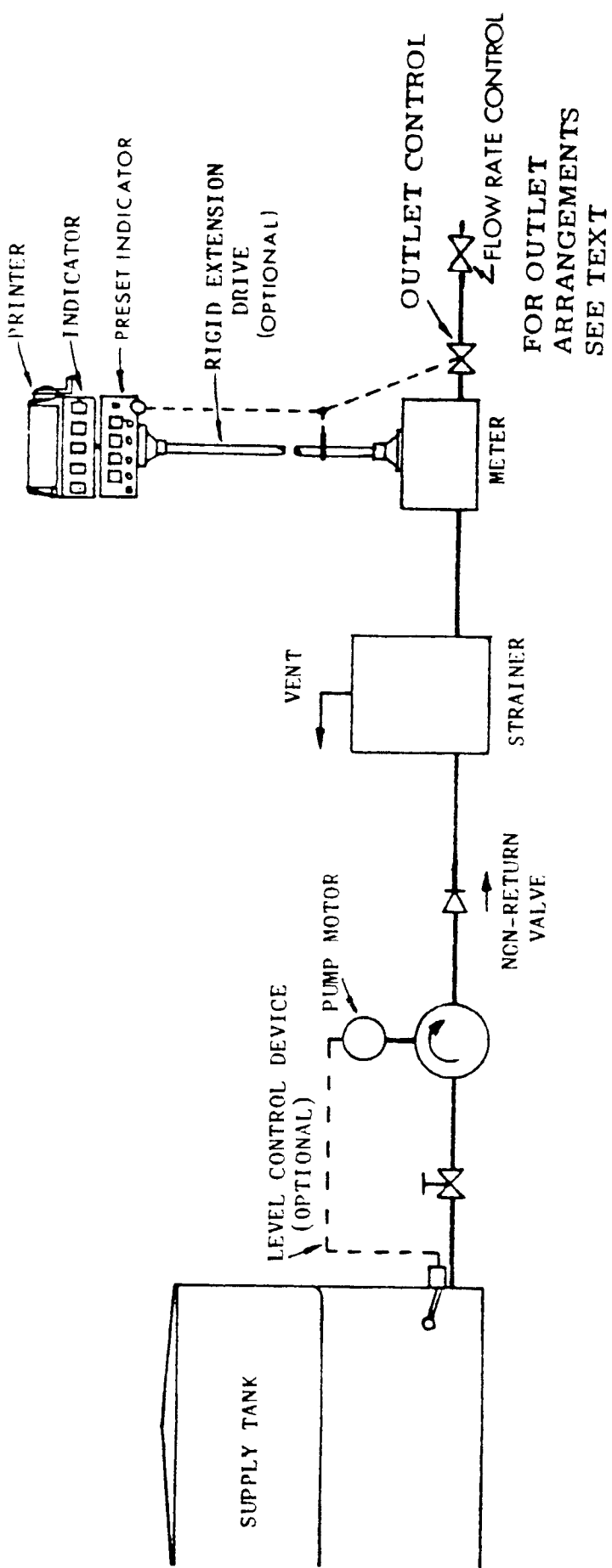

Pipeline Flowmeter - Schematic Diagram

FIGURE 5/6B/49 - 2

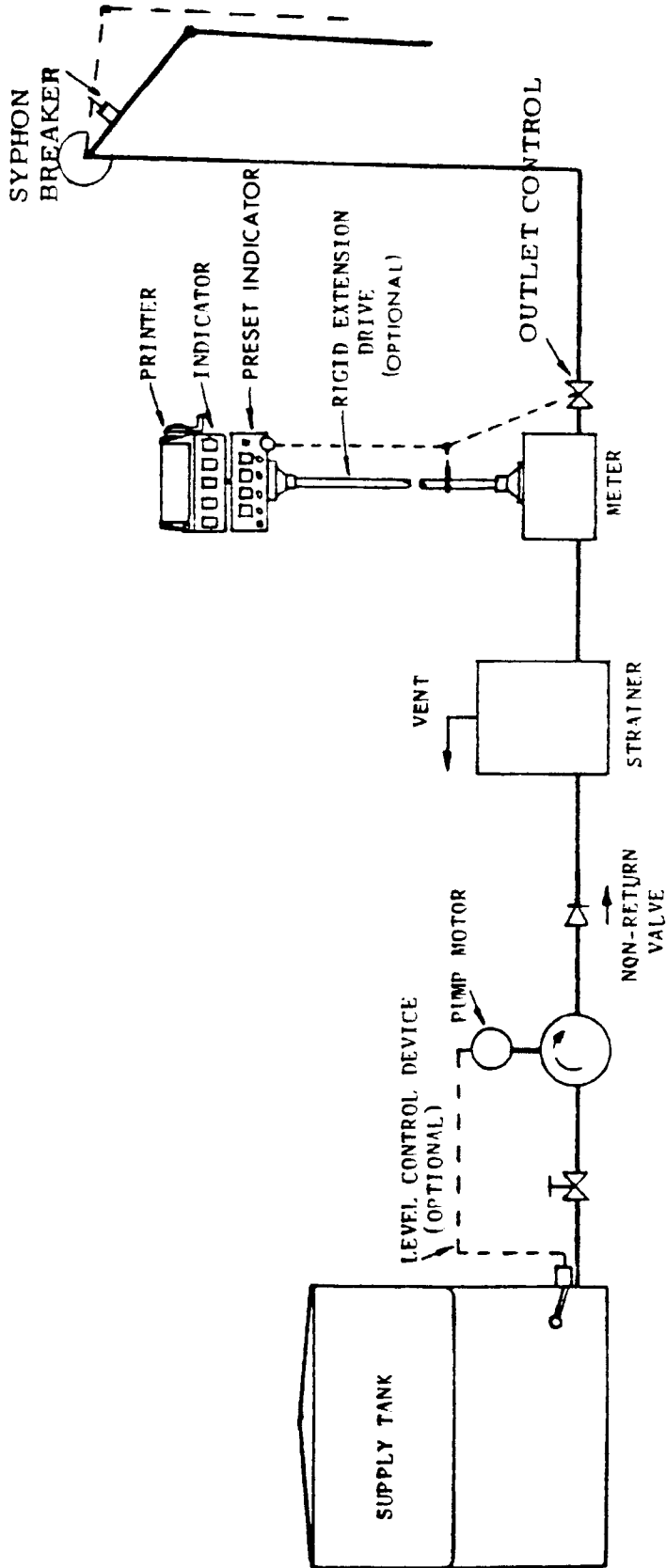

Loading Rack Flowmeter - Schematic Diagram

FIGURE 5/68/49 - 3

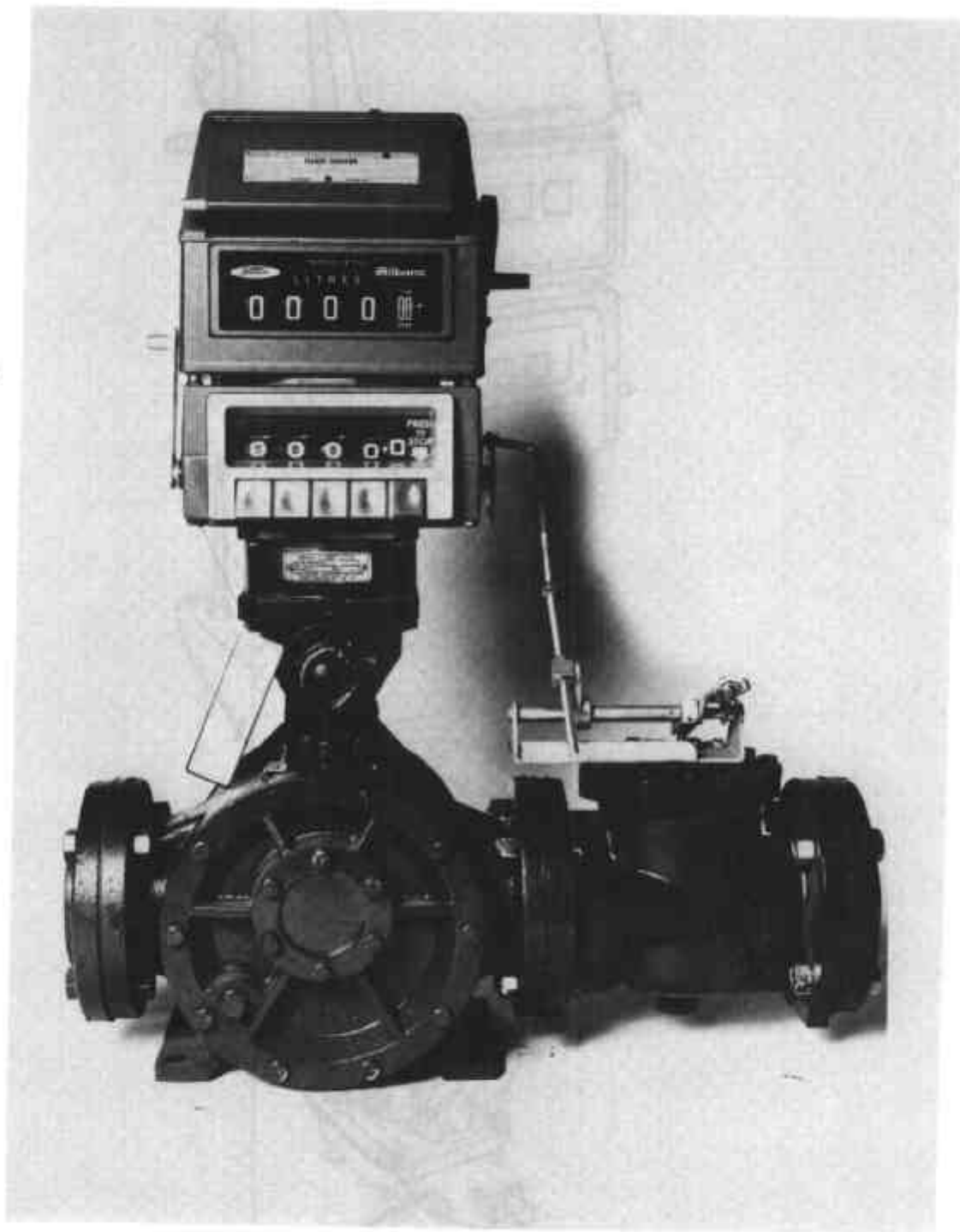

Tokheim 1400 - 30 Meter, Preset Indicator, Indicator, Ticket Printer
and Mechanical Control Valve

28/8/81

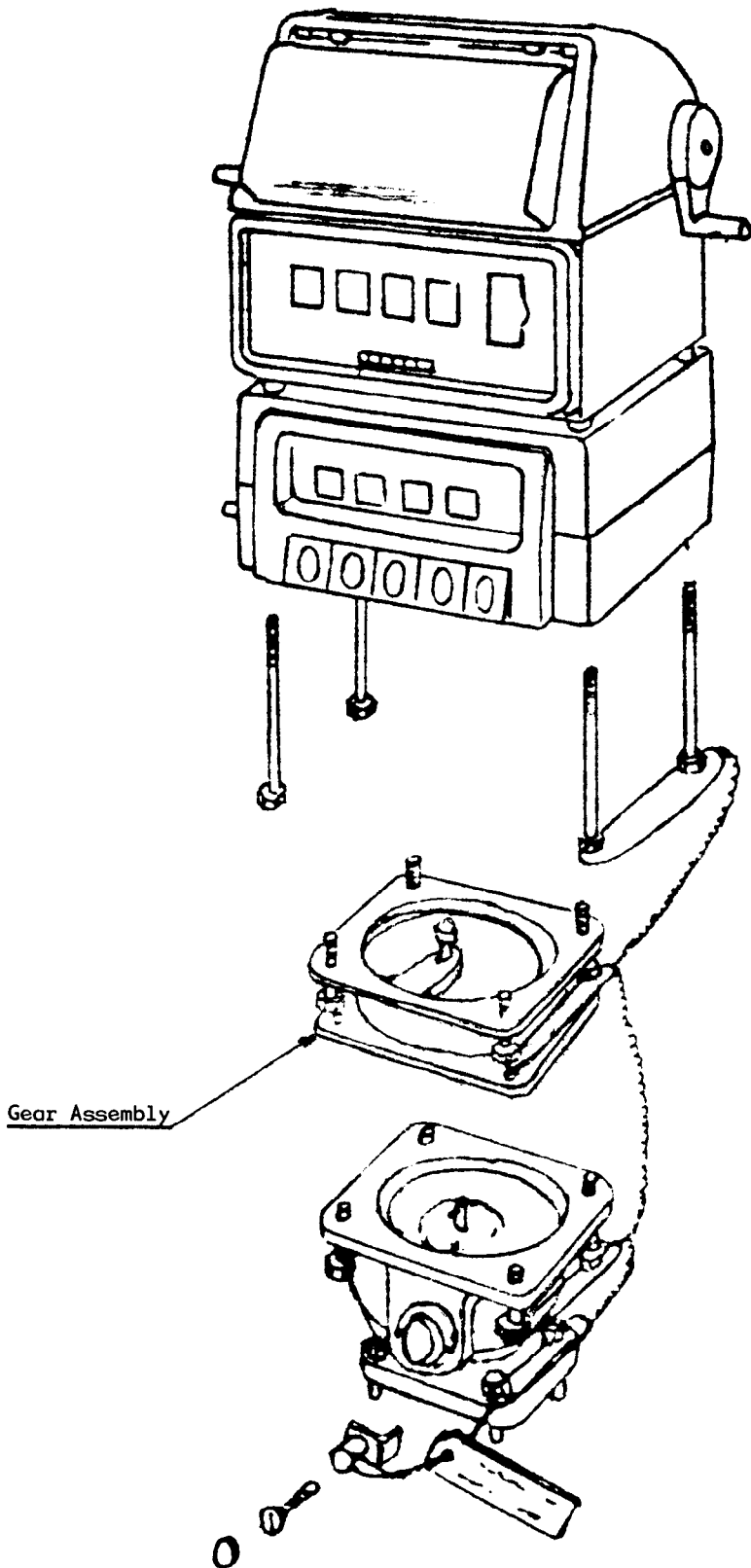

Sealing of Ticket Printer, Indicator, Preset Indicator, Calibrator and separate Gear Assembly (where fitted)

FIGURE 5/6B/49 - 5

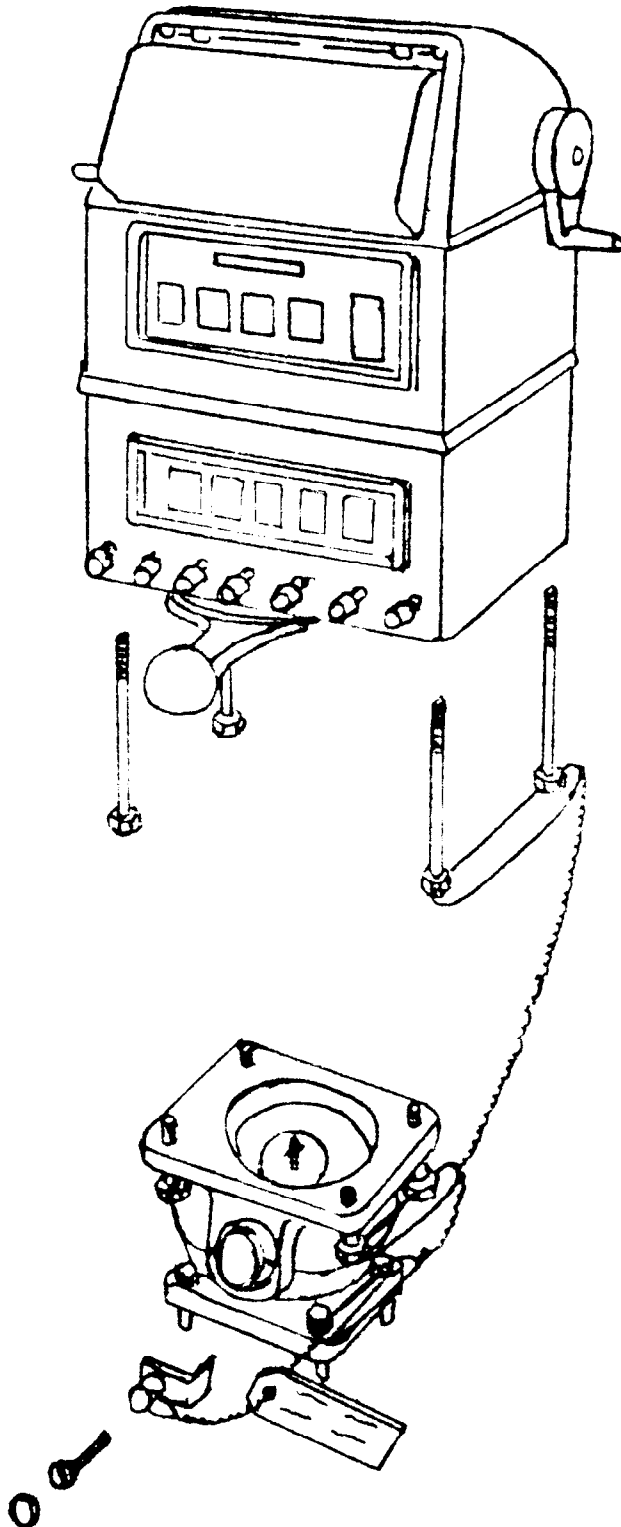

Sealing of Ticket Printer, Indicator, Preset Indicator,
and Calibrator

FIGURE 5/6B/49 - 6

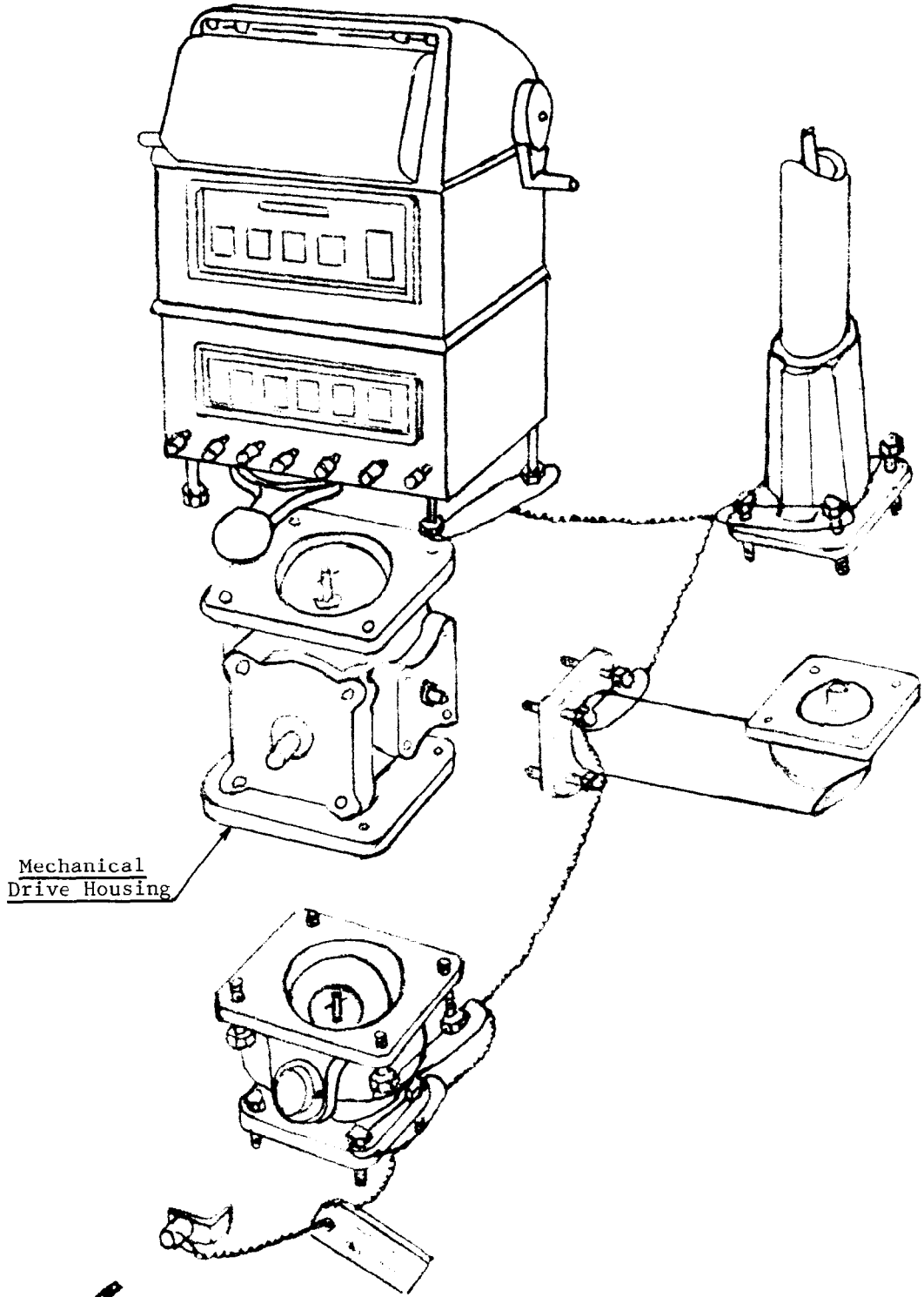

Mechanical
Drive Housing

Sealing of Ticket Printer, Indicator, Preset Indicator,
Calibrator, Mechanical Drive Housing and attachments

FIGURE 5/68/49 - 7

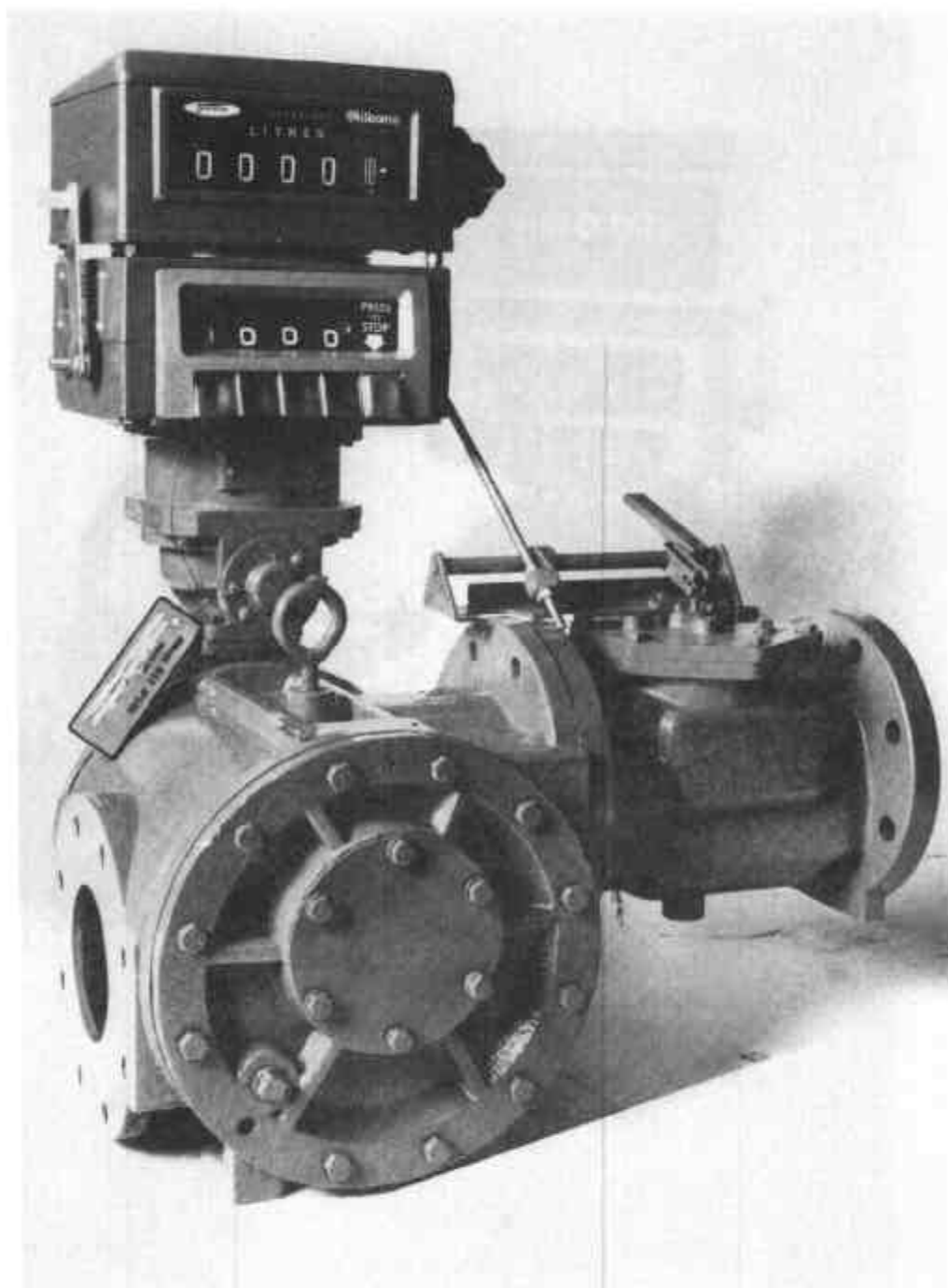

3 in. bore at bolt hole flange.

Tokheim 1450 - 30 Meter, Preset Indicator, Indicator
and Mechanical Control Valve

28/8/81

FIGURE 5/68/49 - B

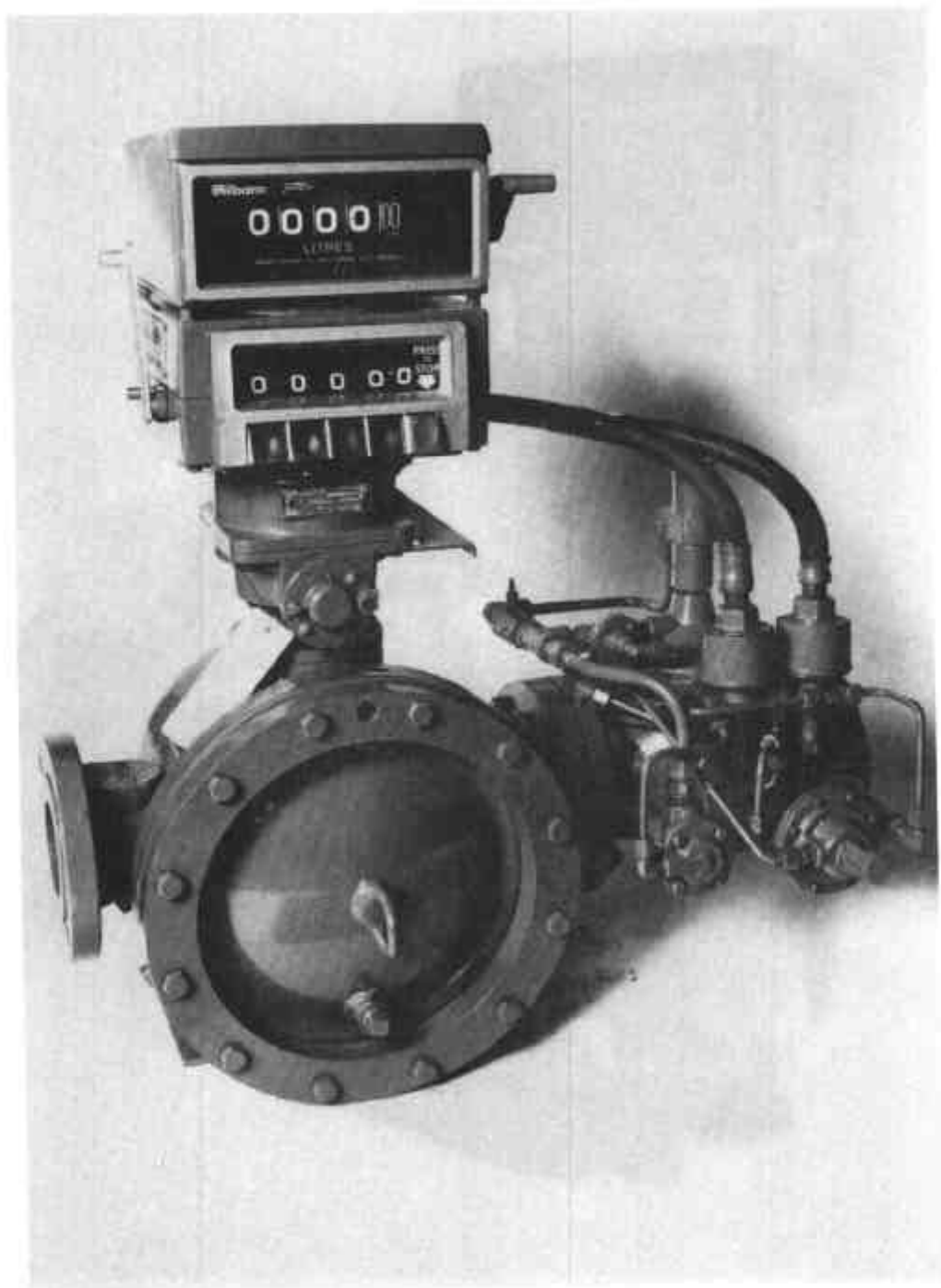

Tokheim 2415 - 30 (similar to 2430 - 30) Meter, Preset
Indicator, Indicator and Electric Control Valve