

CERTIFICATE OF APPROVAL No 5/6A/55
VARIATION No 2

CANCELLED

0/2

This is to certify that the following modifications of the patterns of the
Gilbarco Driveway Flowmeters Model T171D and Others

approved in Certificate No 5/6A/55 dated 19 December 1974 and subsequent
variations

submitted by Gilbarco Australia Ltd,
16-34 Talavera Road,
North Ryde, New South Wales, 2113,

have been approved under the Weights and Measures (Patterns of Instruments)
Regulations as being suitable for use for trade.

Date of Approval: Modification No 1 .. 25 June 1976
Modifications Nos 2 and 3 .. 17 December 1976

The approved modifications, described in Technical Schedule No 5/6A/55 -
Variation No 2 and in drawings and specifications lodged with the
Commission, provide for:

1. Gilbarco T173-0037 pulse transmitter(s);
2. a modified nozzle hang-up holster and starting-lever linkage;
3. relocation of the final filter.

The approval is subject to review on or after 1 January 1980.

All instruments conforming to this approval shall be marked with the
approval number "NSC No 5/6A/55".

Signed

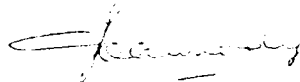

Executive Officer



CANCELLED

NATIONAL STANDARDS COMMISSION

TECHNICAL SCHEDULE No 5/6A/55

Pattern: Gilbarco T171D Driveway Flowmeter

Submittor: Gilbarco Australia Ltd,
16-34 Talavera Road,
North Ryde, New South Wales, 2113.

Date of Approval: 19 December 1974

All instruments conforming to this approval shall be marked "NSC No 5/6A/55".

Description:

The pattern (see Figures 2 and 3) is a Gilbarco Trimline Single Driveway Flowmeter Model T171D, comprising the components listed in Figure 1. The instrument is a dispenser with a remote submerged turbine pump. Each dispenser connected to the pump has a maximum flow rate of 60 litres per minute.

The approval includes:

1. The computer being reset by an electric reset unit; the instrument is then known as a Gilbarco Trimline Single Driveway Flowmeter Model T171E (see Figure 1).
2. Two driveway flowmeters in the one cabinet known as a Gilbarco Trimline Dual Driveway Flowmeter Model T172D, and Gilbarco Trimline Dual Driveway Flowmeter Model T172E when electric reset units are fitted (see Figure 1). The hydraulic diagram of each driveway flowmeter is as illustrated in Figure 3.

Special Tests:

The accuracy of delivery of each driveway flowmeter should be checked when the delivery pipe between the submerged turbine pump and the dispenser is empty of liquid at the start of delivery. The delivery pipe may be emptied by connecting a compressed air hose to the pneumatic test valve in the delivery pipe and opening the pump manual by-pass valve. Emptying of the delivery pipe may be observed in the pump by-pass sight glass. (It should be noted that when the nozzle valve is opened only a small amount of liquid may be delivered and the delivery may stop until the air in the delivery pipe is purged by the gas separator.)



NATIONAL STANDARDS COMMISSION

TECHNICAL SCHEDULE No 5/6A/55

VARIATION No 1

Pattern: Gilbarco T171D Driveway Flowmeter

Submittor: Gilbarco Australia Ltd,
16-34 Talavera Road,
North Ryde, New South Wales, 2113.

Date of Approval of Variation: 30 January 1976

The modification described in this Schedule applies to the patterns described in Technical Schedule No 5/6A/55 dated 13 March 1975.

All instruments conforming to this approval shall be marked "NSC No 5/6A/55".

Description:

The approved modification provides for a ZVA Slimline automatic hose nozzle (see Figures 4 and 5). The anti-drain valve which is integral with the main valve retains a pressure of not less than 15 kPa. A swivel hose coupling is fitted to the nozzle.



NATIONAL STANDARDS COMMISSION

TECHNICAL SCHEDULE No 5/6A/55

VARIATION No 2

Pattern: Gilbarco Driveway Flowmeters Model T171D and Others approved in Certificate No 5/6A/55 dated 19 December 1974 and subsequent variation

Submittor: Gilbarco Australia Ltd,
16-34 Talavera Road,
North Ryde, New South Wales, 2113.

Dates of Approval of Variation: 25 June 1976 and 17 December 1976

The modifications described in this Schedule apply to the patterns described in Technical Schedule No 5/6A/55 dated 13 March 1975 and Technical Schedule No 5/6A/55 - Variation No 1 dated 15 April 1976.

All instruments conforming to this approval shall be marked "NSC No 5/6A/55".

Description:

The approved modifications provide for:

1. A Gilbarco T173-0037 pulse transmitter (see Figure 6) on the quantity and/or price drive shaft of the Veeder-Root VR 101 computer in each of the approved driveway flowmeter models.

The output from the pulse transmitter(s) may be used to provide data to peripheral devices which are not a part of the measuring instrument.* These devices, which may only be provided with the authorisation of the Weights and Measures Authority of the State, may, for example, print receipts or store and process the data, etc. The use of such peripheral equipment will not affect the operation of the driveway flowmeter.

2. The holster of the Gilbarco T171E and T172E driveway flowmeters fitted with a bracket which prevents the starting lever being lifted up beyond its "on" position (see Figure 7). The linkage

* The measuring instrument examined and approved by the Commission is limited to the devices which determine the value of a physical quantity, control the measurement, and indicate the result of the measurement on a non-permanent visual display, for example, a seven-segment indicator or Veeder-Root computer.

connecting the starting lever to the cams in the electric reset unit is illustrated in Figures 8 and 9.

3. A "final filter" unit fitted on the side of the cabinet between the back-pressure valve and the hose, or between the hose and the nozzle.

FIGURE 5/6A/55 - 1

1	2	3	4	5	6	7
Identi- fication No	Components	Foot- notes	T171D Single	T171E Single	T172D Dual	T172E Dual
1.4	Submerged turbine pump assembly		*	*	*	*
2.6	T257AH gas-separation system		*	*	*	*
5.5	T262X meter		A	A		
5.7	T262Y meter		A	A		
5.8	T262S meter				A	A
5.10	T262T meter				A	A
6.10	VR 1611 computer		B		B	
6.12	VR 1613 computer		B		B	
6.14	VR 101 computer		B	*	B	*
7.1	T162-6 back-pressure valve		*	*	*	*
8.7	T261X sight glass (spinner)		C	C	C	C
8.8	T261X sight glass (balls)		C	C	C	C
9.3	T250H manual hose nozzle		D	D	D	D
9.7	OPW1A automatic hose nozzle		D	D	D	D
9.8	STM 363 automatic hose nozzle		D	D	D	D
9.9	EMCO 200A automatic hose nozzle		D	D	D	D
10.5	Nozzle hang-up (240 mm)		*		*	
10.7	Nozzle hang-up (starting lever)			*		*
11.1	Electric reset unit			*		*
12.3	Data plate — "approved for petroleum $\leq 1 \text{ mm}^2/\text{s}$ "		*	*	*	*
14.2	T040-0068 gas-separation test valve		*	*	*	*
16.2	Final filter		‡	‡	‡	‡

- * - indicates required component
- A - indicates alternative components, one of which is required
- B to D - as for A
- ‡ - indicates optional component

Compatibility Table for Components Described
in this Technical Schedule

13/3/75

FIGURE 5/6A/55 - 2

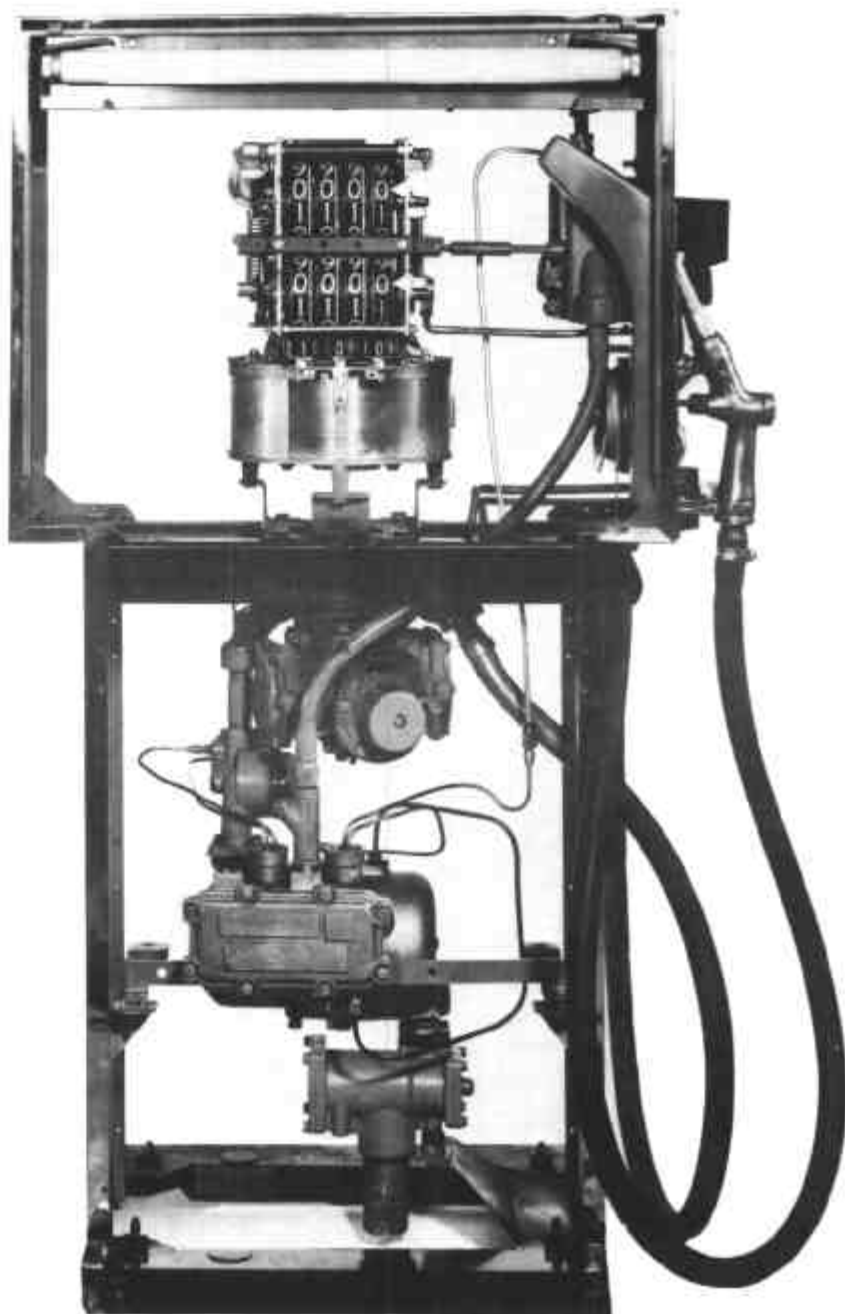

T171D Driveway Flowmeter

13/3/75

FIGURE 5/6A/55 - 3

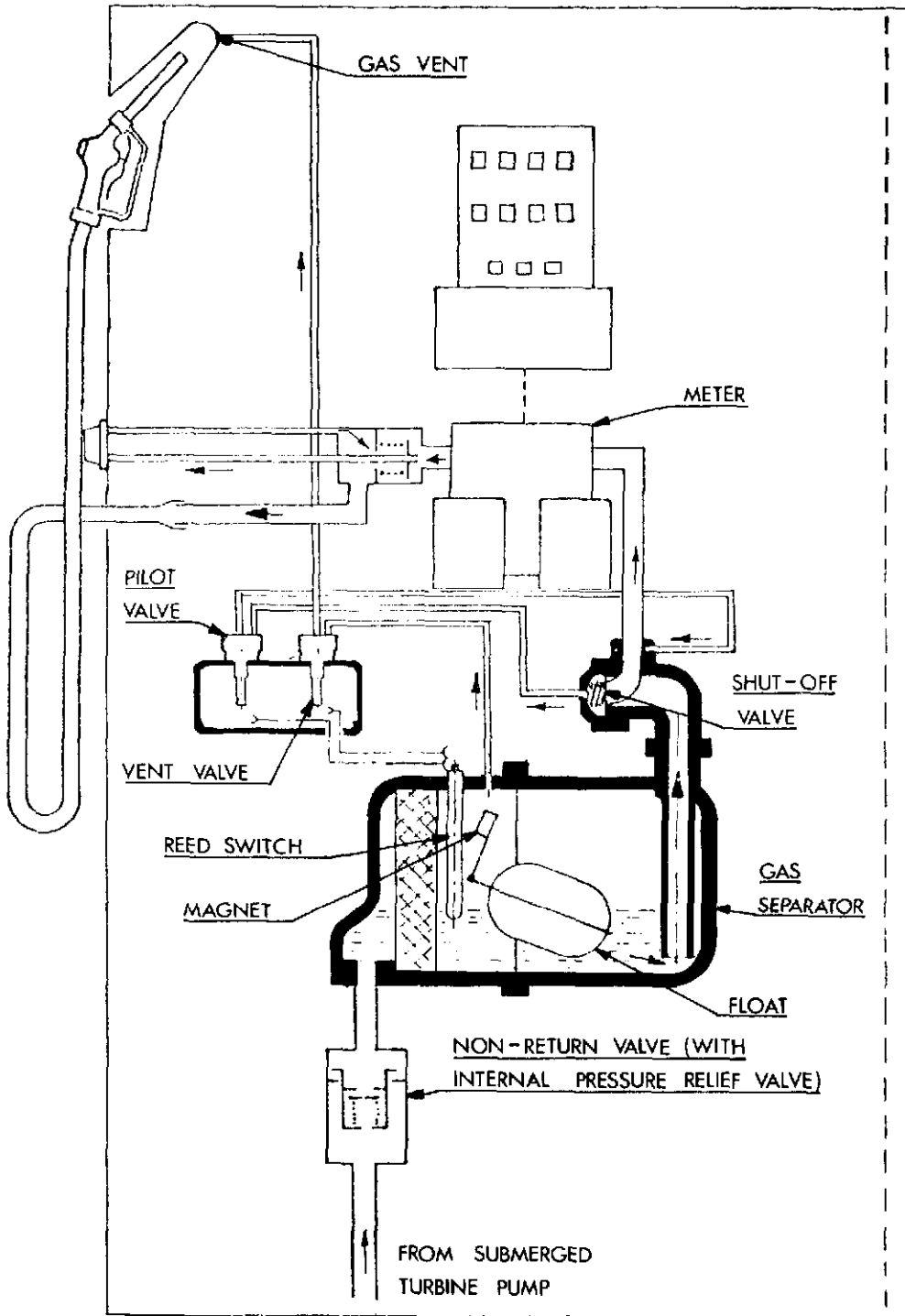

T171D Driveway Flowmeter — Hydraulic Diagram

13/3/75

FIGURE 5/6A/55 - 4



ZVA Slimline Automatic Hose Nozzle

FIGURE 5/6A/55 -- 5

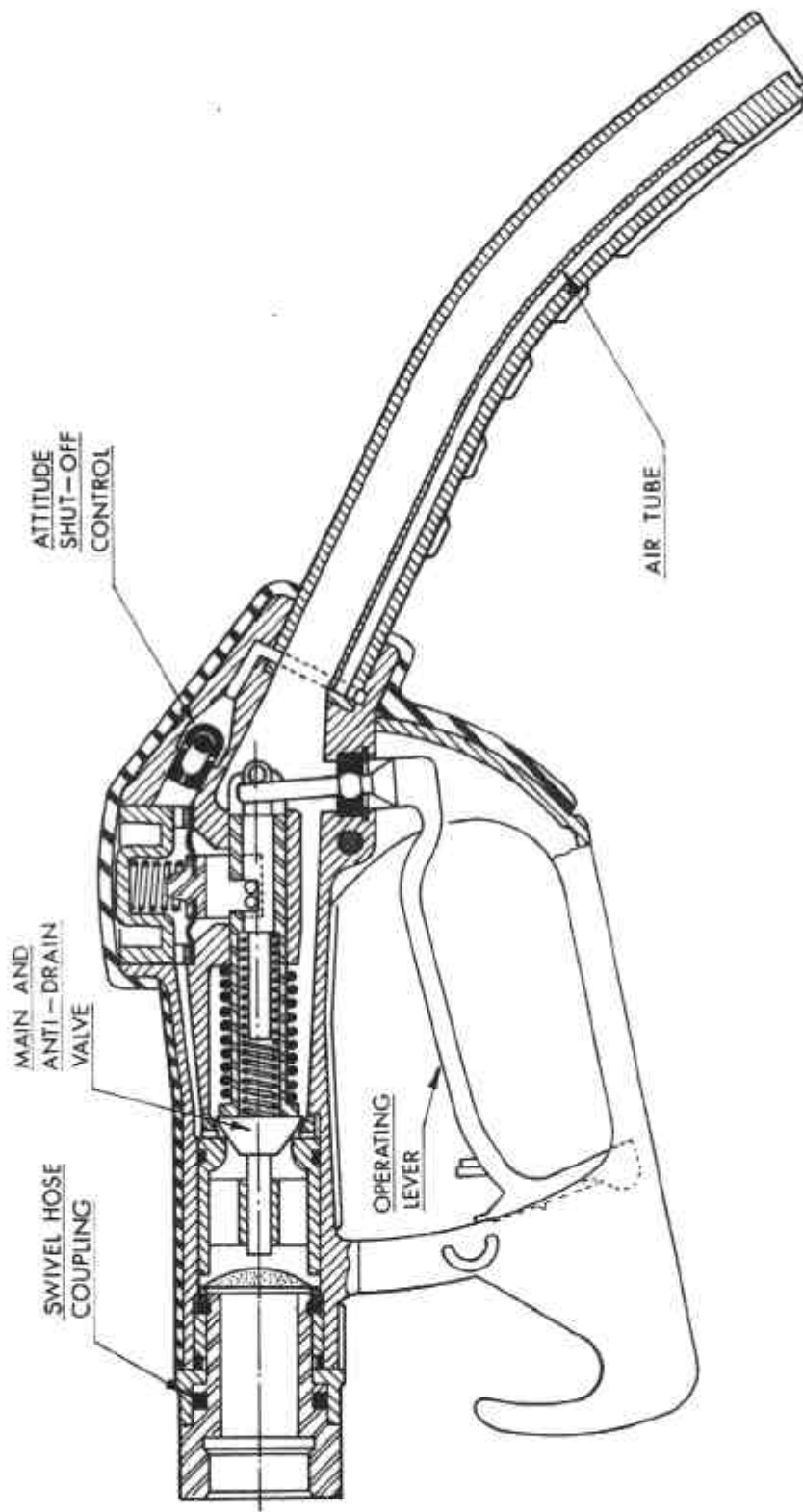

ZVA Slimline Automatic Hose Nozzle



Gilbarco T173-0037 Pulse-transmitter Unit

10/3/77



Hang-up Bracket

10/3/77

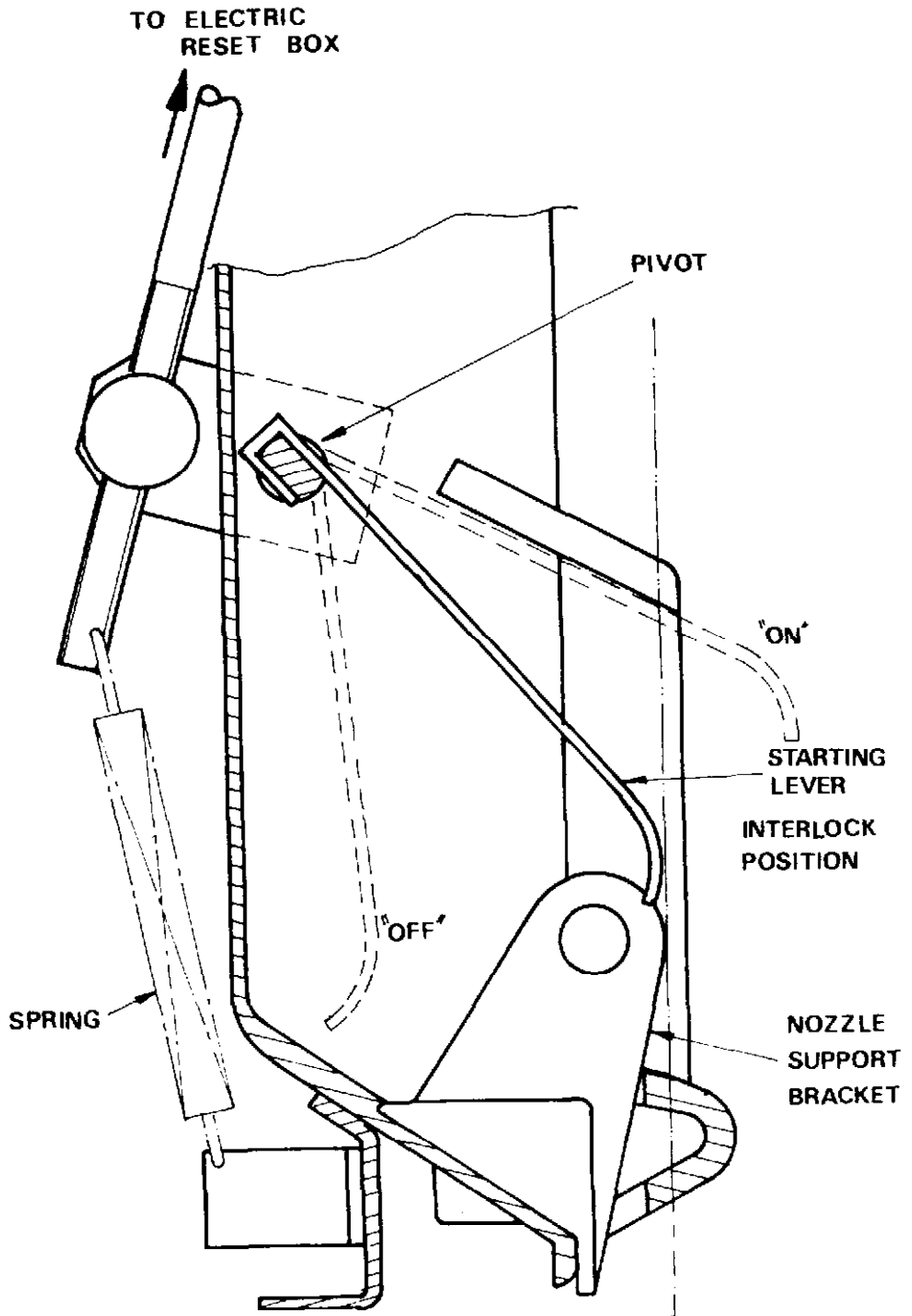

Hang-up for Gilbarco Driveway Flowmeter Model T171E

10/3/77

FIGURE 5/6A/55 - 9

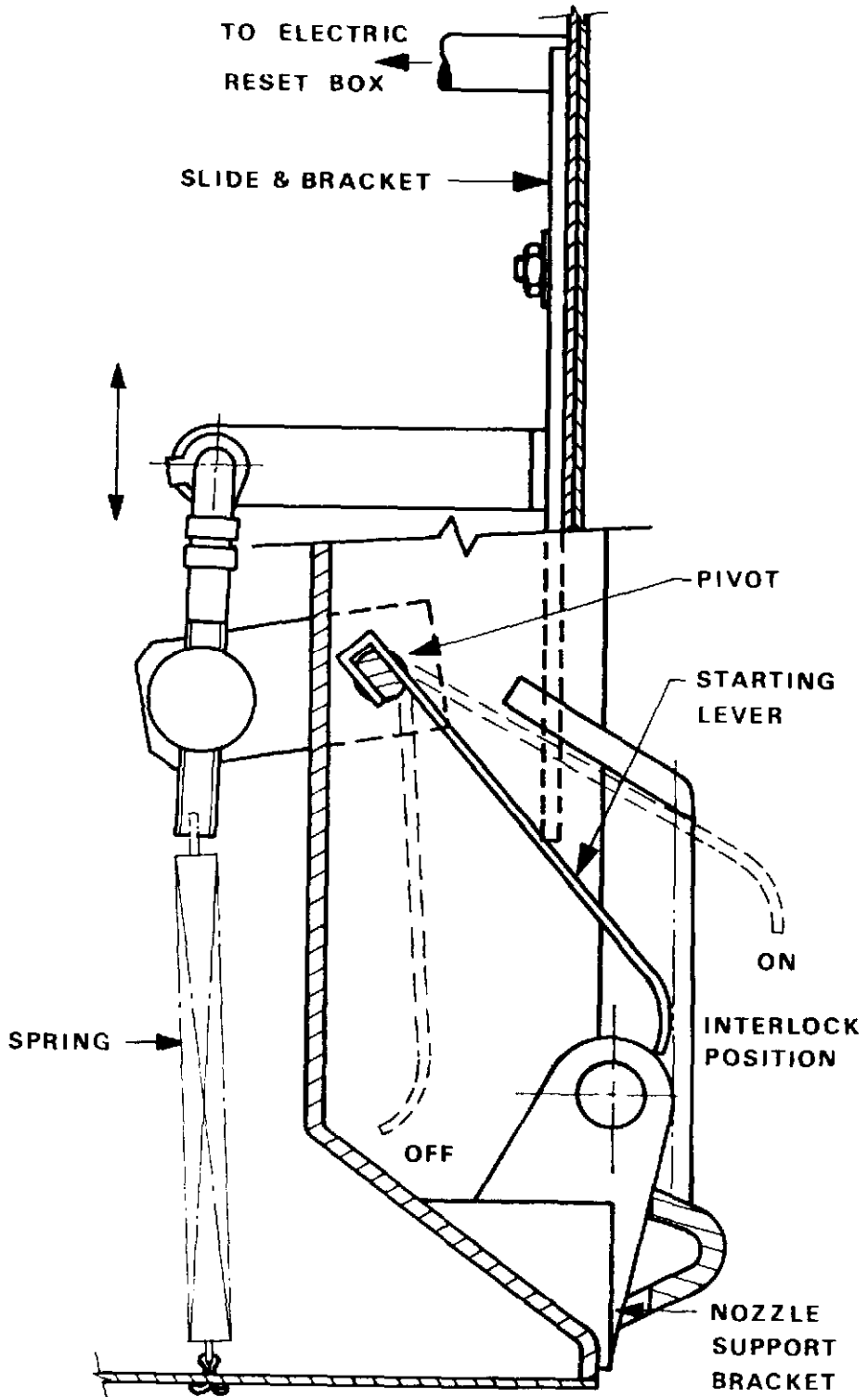

Hang-up for Gilbarco Driveway Flowmeter Model T172E

10/3/77