



Australian Government

**Department of Industry,
Science and Resources**

**National
Measurement
Institute**

36 Bradfield Road, West Lindfield NSW 2070

**Certificate of Approval
NMI 5/6B/87B**

Issued by the Chief Metrologist under Regulation 60
of the
National Measurement Regulations 1999

This is to certify that an approval for use for trade has been granted in respect of the instruments herein described.

Smith Meter® Model K2GD Liquid-measuring System

submitted by TechnipFMC
FMC Technologies Measurement Solutions Inc.
1602 Wagner Avenue
Pennsylvania 16610
United States of America

NOTE: This Certificate relates to the suitability of the pattern of the instrument for use for trade only in respect of its metrological characteristics. This Certificate does not constitute or imply any guarantee of compliance by the manufacturer or any other person with any requirements regarding safety.

This approval has been granted with reference to document NMI R 117, *Measuring Systems for Liquids Other than Water*, dated June 2011.

This approval is subject to review at the decision of the Chief Metrologist in accordance with the conditions specified in the document NMI P 106.

DOCUMENT HISTORY

Rev	Reason/Details	Date
0	Pattern & variant 1 approved – certificate issued	11/03/09
1	Variant 2 provisionally approved – interim certificate issued	13/03/14
2	Variant 2 amended – interim certificate issued	29/05/14
3	Variant 2 amended (validity) – interim certificate issued	8/08/14
4	Pattern & variant 1 updated & reviewed – variant 2 approved – certificate issued	18/02/15

Document History (cont...)

Rev	Reason/Details	Date
5	Pattern amended (submitted by) – certificate issued	06/07/20
6	Variant 1 amended – certificate issued	28/07/21
7	Variant 3 approved – certificate issued	18/11/22

CONDITIONS OF APPROVAL

General

Instruments purporting to comply with this approval shall be marked with pattern approval number 'NMI 5/6B/87B' and only by persons authorised by the submittor.

Instruments purporting to comply with this approval and currently marked 'NMI P5/6B/87B' may be re-marked 'NMI 5/6B/87B' but only by persons authorised by the submittor.

It is the submittor's responsibility to ensure that all instruments marked with this approval number are constructed as described in the documentation lodged with the National Measurement Institute (NMI) and with the relevant Certificate of Approval and Technical Schedule. Failure to comply with this Condition may attract penalties under Section 19B of the National Measurement Act and may result in cancellation or withdrawal of the approval, in accordance with document NMI P 106.

Auxiliary devices used with this instrument shall comply with the requirements of General Supplementary Certificates No S1/0/A or No S1/0B.

Signed by a person authorised by the Chief Metrologist to exercise their powers under Regulation 60 of the *National Measurement Regulations 1999*.



Alex Winchester
A/g Manager
Policy and Regulatory Services

TECHNICAL SCHEDULE NMI 5/6B/87B

1. Description of Pattern **approved on 11/03/09**

A bulk flowmetering system (Figure 1 and Table 1) incorporating a Smith Meter® model K2GD (*) 80 mm turbine flowmeter interfaced to a Smith Meter Inc AccuLoad III ALIII series calculator/indicator designed predominantly to control the loading/transfer of petroleum products other than LPG, including pure ethanol and ethanol/gasoline blends, biodiesel and biodiesel/distillate blends (to Australian government standard).

(*) Abbreviated model number

1.1 Field of Operation

The field of operation of the measuring system is determined by the following characteristics:

• Minimum measured quantity, V_{min}	200 L	(#1)
• Maximum flow rate, Q_{max}	2650 L/min	
• Minimum flow rate, Q_{min}	265 L/min	
• Maximum pressure of the liquid, P_{max}	1965 kPa	
• Minimum pressure of the liquid, P_{min}	200 kPa	(#2)
• Dynamic viscosity range at 20°C	0.5 to 20 mPa.s	(#3)
• Maximum temperature of the liquid, T_{max}	50°C	
• Minimum temperature of the liquid, T_{min}	-10°C	
• Maximum ambient temperature	55°C	
• Minimum ambient temperature	-25°C	
• Accuracy class	0.5	

(#1) When the calculator/indicator is set to indicate volume in 0.1 L increments.

(#2) For satisfactory operation of the gas elimination device.

(#3) The flowmeter is adjusted to be correct for the liquid for which it is to be verified/ certified as marked on the data plate.

1.2 System Description

(i) Tank

A supply tank may incorporate a device for detecting low liquid level. The detector is used to prevent further deliveries when the low liquid level is reached, and to prevent air from entering the pipework.

(ii) Pump

The pump is required to have sufficient capacity to allow flow rates at least three times the minimum flow rate specified for the flowmeter. If the pump is not for the exclusive use of the flowmeter, the pump shall be of sufficient capacity to ensure that flow rate through each meter is maintained above its respective specified minimum flow rate and the pressure is maintained above the minimum backpressure recommended for each meter for all combinations of alternative uses of the pump.

A positive displacement type, centrifugal type, or submersible turbine type pump may be installed in a flooded suction configuration.

Systems with positive displacement pumps are installed so that the pump stops when the liquid level in the supply tank is low. If the pump is above the liquid level of the supply tank, the system shall include a gas elimination device capable of continuously separating any air/vapour entrained in the liquid upstream of the flowmeter.

Systems which incorporate submersible turbine type pumps may in addition include centrifugal type pumps fitted above the liquid level in the supply tank as supplementary pumps. These systems shall include a gas elimination device capable of removing any pockets of air/vapour that may form (particularly in shut-down period) in the pipework upstream of the flowmeter

(iii) Non-return Valve

A non-return valve is fitted between the pump and the flowmeter to prevent reverse flow and to keep the pipework full of liquid at all times.

(iv) Gas Elimination Device

A 100 mm (4 inch) Smith Meter Inc model E-40A-40-V-O-O-R2 gas extractor with an integral strainer assembly, or any other equivalent gas elimination device, is fitted as close as practical to the meter inlet (Figure 2). A 100 × 80 mm reducer is fitted between the gas extractor and the inlet flow conditioner of the flowmeter.

The gas elimination device assembly may be modified for use as a strainer only where the tank has automatic alarming of low-liquid, or has a float-operated shut-off valve in the pump supply, or has other means to prevent gas entering the system.

(v) Flow Straighteners

The turbine flowmeter requires flow conditioners consisting of flow conditioners of at least 10 pipe diameters and 5 pipe diameters in length, installed respectively upstream and downstream of the meter. The upstream conditioner has in-line straightening vane inserts. The pipe diameter is required to be the same diameter as the turbine flowmeter.

A strate plate, normally integral with the turbine meter, may also be used as the method of flow conditioning.

(vi) Measurement Transducer

A Smith Meter Inc model K2GD (*) 80 mm turbine flowmeter (Figure 3) with accuracy class 0.3 has dual pickup coils for producing an electrical output signal proportional to volume throughput. The signal is connected to a Smith Meter Inc model PA-6 preamplifier that conditions the signal and provides a pulse output for a compatible approved calculator/indicator. The preamplifier requires an input voltage in the range 8 to 29 volts DC and produces a corresponding pulse output depending on the supply voltage and the applied load. The preamplifier provides a pulse output equal to 0.5, 1 or 2 times the input signal.

(*) Abbreviated model number – refer to Table 1 for explanations.

The cyclic volume of the flowmeter is 0.86 L and the nominal k-factor for the flowmeter is 13.9 pulses/litre.

Provision is made in the pipework to verify the temperature and pressure of the liquid flowing through the measurement transducer.

For use in **horizontal** applications only.

(vii) Calculator/Indicator

The dual pulse output from the meter preamplifier is interfaced to a Smith Meter Inc AccuLoad III ALIII series calculator/indicator as described in the documentation of approval NMI S413, or may be interfaced to any other compatible electronic calculator/indicator approved for non-interruptible systems. For temperature converted volume to 15°C, a temperature probe is fitted downstream of the flowmeter.

(viii) Transfer Device

A transfer device, such as a Smith Meter Inc model 210 automatically-operated control valve, or any other compatible positive shut-off valve located downstream of the meter, or a decoupling valve may incorporate a back pressure check valve fitted to the end of a loading arm, with no intermediate outlet, may be used to define the start and finish of volume measurement.

The transfer device may also be designed for controlling the flow rate, or a separate flow control valve may be fitted between the meter and the transfer device, provided that the flow control system maintains the operation of the meter within the approved field of operation.

The pipework between the gas elimination device and the transfer point is maintained full of liquid during the measurement and shutdown periods.

1.3 Descriptive Markings and Notices

Each measuring system shall bear the following information, placed together either on the indicating device or on a data plate:

Pattern approval mark	5/6B/87B	
Manufacturer's identification mark or trade mark	
Meter model	
Serial number of the instrument	
Year of manufacture	
Maximum flow rate, Q_{max} L/min	
Minimum flow rate, Q_{min} L/min	
Maximum pressure of the liquid, P_{max} kPa	(#1)
Minimum pressure of the liquid, P_{min} kPa	
Liquid temperature range to °C	(#2)
Nominal k-factor pulses/L	
Type of liquid for which the system is verified	(#3)
Environmental class	class C	
Accuracy class	0.5	

(#1) Required for systems with flexible outlet pipework.

(#2) Required if temperature converted volume to 15°C is reported.

(#3) This may be located separately, e.g. on a metal tag sealed to the instrument.

The minimum measured quantity (V_{min}) is clearly visible on the indicating device, e.g. 'Minimum Delivery 200 L', or the pre-set of the controller is limited to deliveries equal to or greater than the minimum delivery specified for the flowmeter.

1.3 Verification Provision

Provision is made for the application of a verification mark.

1.4 Sealing Provision

The flowmeter is not required to be sealed. The calibration adjustment provided by the calculator/indicator should be sealed as described in its approval documentation.

2. Description of Variant 1

approved on 11/03/09
amended on 28/07/21

Using any of the Smith Meter Inc K series of turbine flowmeters listed below in Table 1. These models are for use in **horizontal** applications only.

TABLE 1

Flowmeter Model Number (*)	Nominal Bore (mm)	Maximum Flow (Q_{max}) (L/min)	Minimum Flow (Q_{min}) (L/min)	Minimum Delivery (L)
K2EA (#1)	38	530	50	50
K2EB (#2)	50	1060	106	100
K2GD (pattern)	80	2650	265	200
K2GE (#3)	100	4500	450	500
K2BD (#4)	80	2460	246	500
K2BE (#4)	100	4500	450	1000

- (*) Abbreviated model number – the full model numbers may have additional alphanumeric characters, e.g. K2GD***3*** where ‘3’ refers to dual pickup coils/dual amplifiers and the other additional characters relate to non metrological features such as flange types.
- (#1) The transfer device is a Wiggins type ZZ7 decoupling valve or equivalent, fitted to the end of a loading arm. A model S2-1-ST-40-R2-0 gas elimination device or similar approved device is fitted before the flow conditioner. A Smith Meter Inc model 200-50B-30A control valve or any other positive shut-off valve located downstream of the meter may be used to control the flow and/or define the transfer point.
- (#2) A model E-30A-40-V-O-O-R2 gas elimination device or similar approved device is fitted before the flow conditioner.
- (#3) A model E-40A-40-V-O-O-R2 gas elimination device or similar approved device is fitted before the meter.
- (#4) Model fitted with external flow conditioners

3. Description of Variant 2 **provisionally approved on 13/03/14**
approved on 18/02/15

With certain models of the Smith Meter Inc Guardsman K series of turbine flowmeters listed below in Table 2. These models are for use in **vertical** applications only.

TABLE 2

Flowmeter Model Numbers (*)	Nominal Bore (mm)	Maximum Flow (Q_{max}) (L/min)	Minimum Flow (Q_{min}) (L/min)	Minimum Delivery (L)
K2SD	80 (**)	2650 (**)	265 (**)	200 (**)
K2SE	100	4500	460	500

(*) Abbreviated model number – the full model numbers may have additional alphanumeric characters, e.g. K2SD***3** where ‘3’ refers to dual pickup coils/dual amplifiers and the other additional characters relate to non metrological features such as flange types.

(**) Same as for the pattern.

3.1 Field of Operation

The field of operation of variant 2 measuring systems using 80 mm flowmeters is the same as that specified for the pattern in clause **1.1 Field of Operation**, and in Tables 1 and 2.

The field of operation of variant 2 measuring systems using 100 mm flowmeters is the same as that specified for the pattern in clause **1.1 Field of Operation**, except as specified in Table 2 above.

4. Description of Variant 3 **approved on 18/11/22**

Using any of the Smith Meter Inc Guardsman K series of turbine flowmeters listed below in Table 3. These models are for use in **horizontal or vertical** applications.

TABLE 3

Flowmeter Model Number (*)	Nominal Bore (mm)	Maximum Flow (Q_{max}) (L/min)	Minimum Flow (Q_{min}) (L/min)	Minimum Delivery (L)
K2CA	38	500	50	100

(*) Abbreviated model number – the full model numbers may have additional alphanumeric characters, e.g. K2CA***3*** where ‘3’ refers to dual pickup coils/dual amplifiers and the other additional characters relate to non metrological features such as flange types.

TEST PROCEDURE

Instruments shall be tested in accordance with any relevant tests specified in the National Instrument Test Procedures.

The instrument shall not be adjusted to anything other than as close as practical to zero error, even when these values are within the maximum permissible errors.

A suitable Test Procedure may be obtained from NMI

Maximum Permissible Errors

The maximum permissible errors are specified in Schedule 1 of the *National Trade Measurement Regulations 2009*.

FIGURE 5/6B/87B – 1

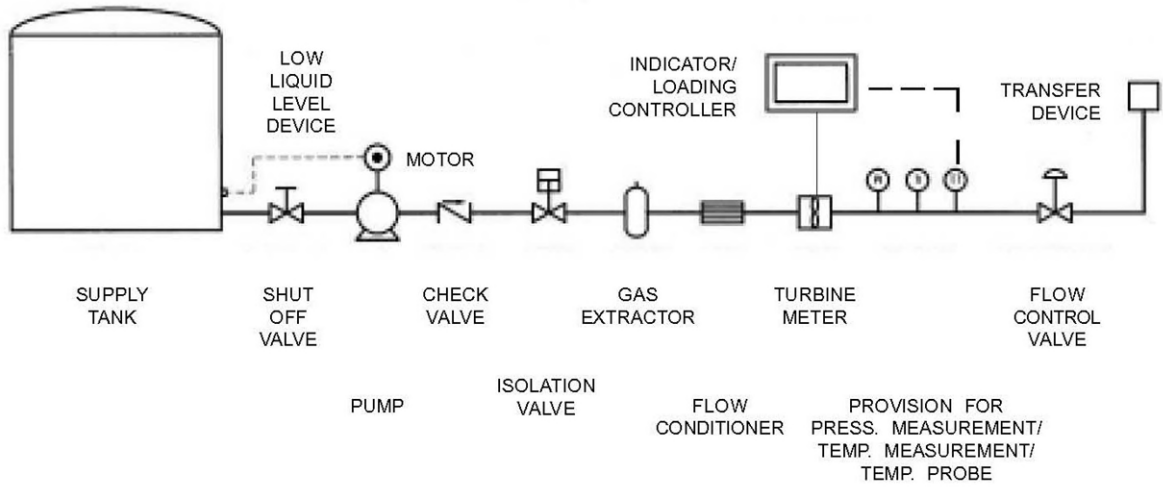

Typical Smith Meter Inc Turbine Horizontal Bulk Flowmetering System (The Pattern)

FIGURE 5/6B/87B – 2



Smith Meter Inc Model E-40A-40-V-O-O-R2 Gas Extractor

FIGURE 5/6B/87B – 3



Smith Meter Inc Model K2GD 80 mm Turbine Flowmeter

FIGURE 5/6B/87B – 4



Smith Meter Inc Model K2EA 38 mm Turbine Flowmeter (Variant 1)

~ End of Document ~