



Australian Government  
Department of Industry and Science

## National Measurement Institute

# General Certificate of Approval

## NMI 3/0B

Issued by the Chief Metrologist under Regulation 60  
of the  
National Measurement Regulations 1999

This is to certify that an approval for use for trade and other legal purposes has been granted in respect of the material measures herein described.

Weights of Certain Denominations

**NOTE:** This Certificate relates to the suitability of the pattern of material measures for use for trade and other legal purposes only in respect of their metrological characteristics. This Certificate does not constitute or imply any guarantee of compliance by the manufacturer or any other person with any requirements regarding safety.

This approval becomes subject to review on **1/06/22**, and then every 5 years thereafter.

### DOCUMENT HISTORY

Rev	Reason/Details	Date
0	Pattern & variants 1 to 3 approved – certificate issued	26/05/09
1	Pattern & variants 1 to 3 updated & reviewed – certificate issued	17/10/12
2	Variant 2 amended (MPEs) – certificate issued	21/02/14
3	Pattern & variants amended (Materials) & <b>reviewed</b> – certificate issued	13/04/17

## CONDITIONS OF APPROVAL

### General

It is the responsibility of the manufacturer or their agents to ensure that all material measures purporting to comply with this approval are constructed in accordance with this General Certificate of Approval and its Technical Schedule. Failure to comply with this Condition may attract penalties under Section 19B of the National Measurement Act.

### Special

The construction details for the pattern and variant 3 can be adopted for weights that are to be used for **verification purposes**, with corresponding maximum permissible uncertainties and maximum permissible variations specified in Schedule 9 of the *National Measurement Regulations 1999*.

### Note

Where the term **lead** is used in this certificate it refers to **lead or other suitable material**.

Signed by a person authorised by the Chief Metrologist to exercise their powers under Regulation 60 of the *National Measurement Regulations 1999*.

A handwritten signature in black ink, appearing to read 'A Rawlinson', with a horizontal line underneath.

**Dr A Rawlinson**

TECHNICAL SCHEDULE No 3/0B

**1. Description of Pattern**

**approved on 26/05/09**

Weights of certain denominations as listed below from 1 mg up to and including 20 kg.

**1.1 Approved Nominal Denominations**

The weights shall be normally limited to the following values:

- 1, 2, 5, 10, 20, 50, 100, 200, 500 mg;
- 1, 2, 5, 10, 20, 50, 100, 200, 500 g; and
- 1, 2, 5, 10, or 20 kg

**1.2 Construction**

**1.2.1 Materials**

Apart from lead inserted for adjustment and stamping, weights shall be made of iron, brass, gun-metal, bronze, non-magnetic stainless steel, nickel-silver, platinum or aluminium, provided weights of less than 100 g shall not be made of iron and weights of less than 50 mg for use in pharmaceutical dispensing shall be made of aluminium or stainless steel.

Weights shall not be composed of two or more different un-alloyed metals, apart from lead for adjustment and stamping.

**1.2.2 Finish**

Every weight shall be clean and free from corrosion, shall be smooth on all surfaces and shall have no flaws. Every iron weight shall be treated with a suitable coating to improve its corrosion resistance. This coating shall withstand shocks and outdoor weather conditions.

Weights shall not have a split ring or other removable parts.

Weights may be plated with a coating of nickel, chromium or zinc.

**1.2.3 Shape**

The weights shall be in one single piece and constructed in accordance with the shapes specified in Table 1.

The dimensions for rectangular iron weights are shown in Figure 1.

For circular-cylindrical weights with handles or knobs, the diameter of the knob shall not be more than 90% of the diameter of the weight.

Weights of less than 1 g and made of flat sheet shall be hexagonal in accordance with Table 1 part (a); if made of wire then the weights shall have the number of segments specified in Table 1 part (b).

### 1.3 Adjusting Cavity

Weights from 50 g to 20 kg shall have an adjusting cavity; weights of less than 50 g shall be solid without an adjusting cavity.

No weight may have more than one adjusting cavity, or any cavity in the base other than an adjusting cavity.

The adjusting cavities in iron weights shall be rectangular or circular, and in non-iron weights shall be circular; the cavities shall not exceed the dimensions shown in Table 2.

The adjusting cavity shall be in the base or the side of the weight and shall not extend to the top face; the cavity shall be undercut and have well-defined edges.

Adjustment of the weight shall be carried out by plugging the adjusting cavity with lead, set firmly and securely below the surface, but not so as to render stamping impracticable or reading of the verification mark difficult. The lead shall be free from flakes or layers, without any fringe around the walls of the cavity, and shall have a clean flat surface. The lead shall have a minimum thickness of 1.5 mm in 50 g and 100 g weights, and 3 mm in weights of 200 g and over.

### 1.4 Marking

- (a) Every weight greater than 500 mg shall be clearly and permanently marked with its value and unit symbol. Where the height of the letters and digits is not specified in Figure 1, it shall be proportional to the size of the mass; for rectangular iron weights, the height is given in Figure 1.

Weights of 500 mg and less may have the unit symbol omitted.

If manufactured of wire in accordance with Table 1 part (b), marking is not required.

Only the following unit symbols shall be used:

tonne – t; kilogram – kg; gram – g; milligram – mg

- (b) The name of the manufacturer, if marked on a weight, shall be in letters not exceeding half the size of the letters indicating the denomination. Weights shall not bear a trade or other mark which could be mistaken for either the denomination or the verification mark.
- (c) Weights intended for use for pharmaceutical dispensing or for weighing precious metals shall be marked 'A'.

### 1.5 Verification Provision

The lead adjustment shall be sealed by the application of a verification mark to the lead surface. Where no lead adjustment is provided the verification mark shall be applied to the metal, or a certificate shall be issued.

### 1.6 Maximum Permissible Errors

The maximum permissible errors for weights for use for trade are specified in Schedule 1 of the *National Trade Measurement Regulations 2009*. For weights that are to be used for verification purposes, refer to the Special Condition of Approval.

## 2. Description of Variant 1

approved on 26/05/09

Metric carat weights of certain denominations as listed below from 0.005 CM to 500 CM, and which shall comply with the pattern except in the following respects:

### 2.1 Approved Nominal Denominations

The weights shall be limited to the following values:

0.005,	0.01,	0.02,	0.05	CM,
	0.1,	0.2,	0.5	CM,
	1,	2,	5	CM,
	10,	20,	50	CM, or
	100,	200,	500	CM

### 2.2 Construction

#### (i) Materials

Metric carat weights of less than 5 CM shall be made of aluminium or stainless steel.

#### (ii) Shape

Metric carat weights of 5 CM or greater shall be circular-cylindrical with knobs; weights of less than 5 CM shall be flat sheet.

### 2.3 Adjusting Cavity

They shall not have an adjusting cavity.

### 2.4 Marking

Metric carat weights of 5 CM or greater shall be clearly and permanently marked with their value and the symbol CM; the symbol may be omitted on weights of less than 5 CM.

### 2.5 Maximum Permissible Errors

The maximum permissible errors are specified in Schedule 1 of the *National Trade Measurement Regulations 2009*.

## 3. Description of Variant 2

approved on 26/05/09

Special industrial weights of various denominations for industrial purposes only, and which shall comply with the pattern except in the following respects:

### 3.1 Approved Nominal Denominations

They may be of any value to suit the purpose for which they are to be used.

### 3.2 Construction

#### (i) Materials

Apart from lead inserted for adjustment and stamping, special industrial weights shall be made of iron, brass, bronze, gun-metal or non-magnetic stainless steel, provided weights of less than 2 kg shall not be made of iron.

**(ii) Shape**

They shall be of a shape dissimilar to any of those described for the pattern.

**3.3 Adjusting Cavity**

An adjusting cavity conforming to the requirements for the nearest denomination described for the pattern shall be provided.

**3.4 Marking**

Special industrial weights shall be marked on the top face with the words FACTORY USE ONLY or NON-RETAIL.

**3.5 Maximum Permissible Errors**

The maximum permissible errors for weights up to and including 20 kg are specified in Schedule 1 of the *National Trade Measurement Regulations 2009*. For non-uniform denominations maximum permissible errors are the same as those applicable to the nearest mass described in Schedule 1. The maximum permissible errors for weights greater than 20 kg should be obtained from the National Measurement Institute.

**4. Description of Variant 3**

**approved on 17/10/12**

High capacity weights of denominations greater than 20 kg, and which shall comply with the pattern except in the following respects:

**4.1 Approved Nominal Denominations**

The nominal value is in the form  $k \times 10^n$  kg, where  $k$  is generally equal to 1, 2 or 5, and  $n$  is a whole number equal to or greater than 2. Denominations which do not comply with this requirement may be permitted at the discretion of the National Measurement Institute.

**4.2 Construction**

High capacity weights must be either cast iron or fabricated steel and have a relatively simple shape, with no sharp edges or corners. They shall not have any cavities liable to cause a rapid accumulation of dirt. Typical shapes are shown in Figures 2 and 3. Other shapes and designs are acceptable provided that the requirements of this variant are met.

If they are intended to run on a flat surface (or on rails), they must be equipped with roller tracks (or grooves) of limited area.

The shapes/dimensions for some typical high capacity weights are shown in Figures 2 and 3. The dimensions assume that the construction is of cast iron with a density of  $8000 \text{ kg/m}^3$ . Weights of other materials should have a density of greater than  $3000 \text{ kg/m}^3$ .

The outer casing of fabricated hollow weights shall be constructed with a minimum wall thickness of 5 mm.

Fabricated hollow weights shall be leak tested. Refer to the Test Procedure below. To facilitate leak testing, a BSP threaded port is located in the body of the mass, preferably inside the adjustment cavity and connecting to the remaining interior space of the mass. This port is sealed with a threaded pressure plug.

### **4.3 Test Procedure (Leak Testing)**

Fabricated hollow weights shall be leak tested during manufacture as described below:

The leak testing shall be conducted by pressurising the internal space of the mass. The mass shall be isolated and disconnected from the pressure source for the duration of the test.

The pressure differential to atmosphere shall be not less than 20 kPa nor more than 60 kPa, measured with a gauge of suitable sensitivity and scale range.

The test pressure shall be maintained for a minimum of one minute.

The criteria for a 'pass' result are that no leakage be detected and that there be no change between the initial and final pressure gauge readings.

Records of the leak testing shall be retained.

### **4.4 Adjusting Cavity**

Weights should be limited to not more than two adjusting cavities. The adjusting cavity/cavities shall be located on the side of the weight. Weights which are used for special applications and which are required to be balanced, may have more than two adjusting cavities. Approval for these special application weights shall be at the discretion of the National Measurement Institute.

The adjusting cavity/cavities shall be of adequate dimensions to provide for an adjustment of not less than 5%, nor greater than 10%, of the volume of the mass.

The adjusting cavity/cavities shall have a watertight enclosure with provision for sealing and for the application of a verification mark.

All threaded screw holes for locating the adjusting hole cover/s shall be blind holes. All screws used shall be a minimum 'M6' in diameter and preferably be of stainless steel with a hexagonal head drive.

### **4.5 Maximum Permissible Errors**

The maximum permissible errors for weights greater than 20 kg should be obtained from the National Measurement Institute. For weights that are to be used for verification purposes, refer to the Special Condition of Approval.

TABLE 1  
Part (a)

Denomination	Iron Weights	Weights Other Than Iron		
20 kg 10 kg 5 kg	Rectangular (see Figure 1)	Circular-cylindrical with handles or knobs		
2 kg 1 kg 500 g 200 g 100 g	Regular Hexagonal flat or Flat-circular			
50 g 20 g 10 g 5 g 2 g 1 g				
500 mg 200 mg 100 mg 50 mg 20 mg 10 mg 5 mg 2 mg 1 mg		Hexagonal flat sheet		

Part (b)

Denomination	Weights Made of Wire		
500, 50 or 5 mg 200, 20 or 2 mg 100, 10 or 1 mg	5 segments	2 segments	1 segment

Shapes for Weights – Pattern and Variant 1

TABLE 2

Denomination	Rectangular cavity		Circular cavity	Minimum distance of lead below surface when new
	Length	Width	Diameter	
	mm		mm	mm
20 kg, 10 kg	50	25	40	10
5 kg, 2 kg	25	13	20	5
1 kg, 500 g	16	13	16	5
200 g	16	10	14	5
100 g	13	8	12	5
50 g	-	-	7	5

Adjusting Cavities – Pattern and Variant 1



FIGURE 3/0B – 1

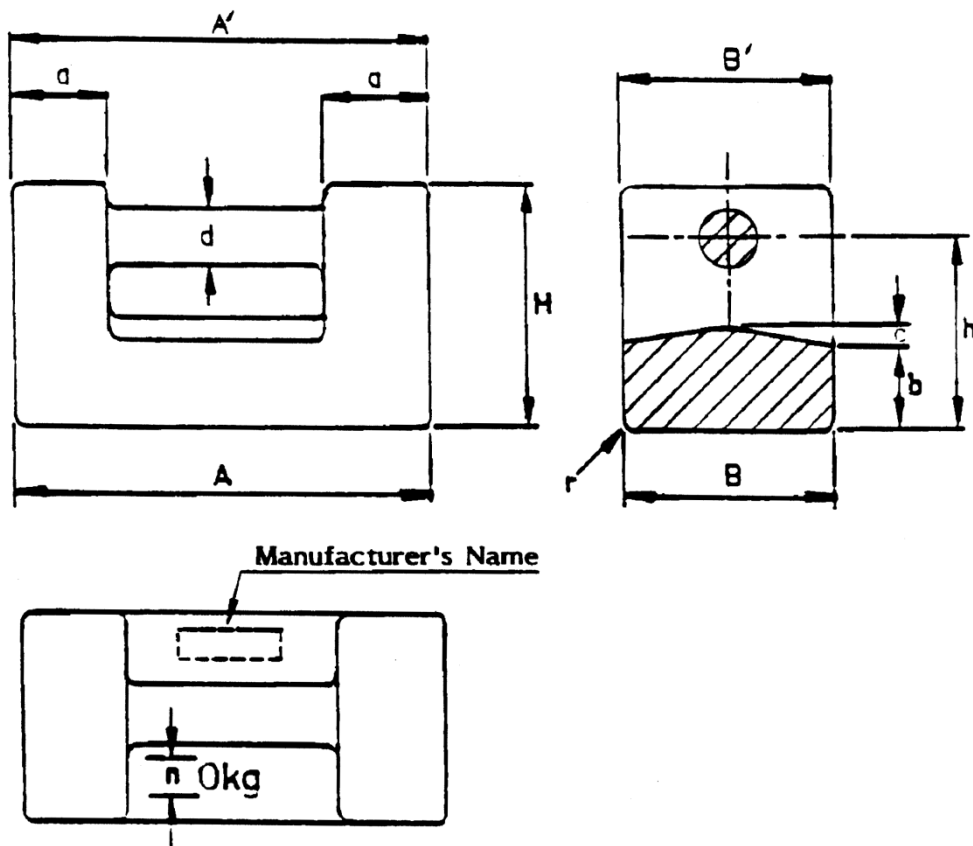

Dimensions in mm

Denomination	A	A'	B	B'	H	a	b	c	h	d	r	n
5 kg	150	152	75	77	84	36	30	6	66	19	5	12
10 kg	190	193	95	97	109	46	38	8	84	25	6	12
20 kg	230	234	115	117	139	61	52	12	109	29	8	20

(Dimensions A, A' & B, B' may be interchanged)

Dimensions for Rectangular Iron Weights – The Pattern

FIGURE 3/0B – 2

Rectangular Weights  
500 kg and 1000 kg  
Suitable for Stacking  
Dimensions (mm)

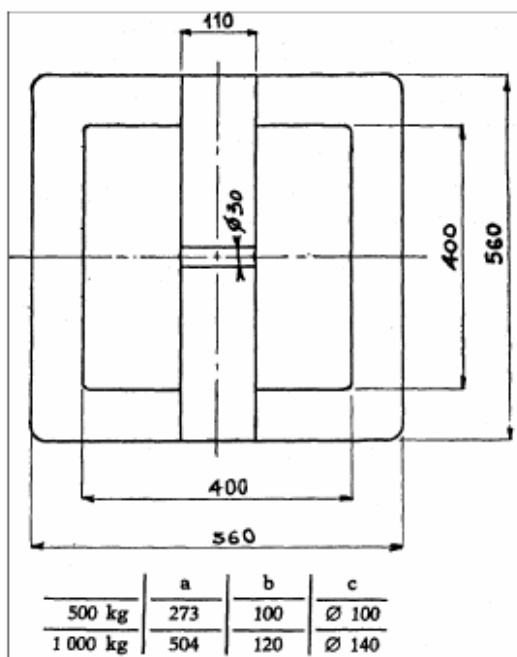
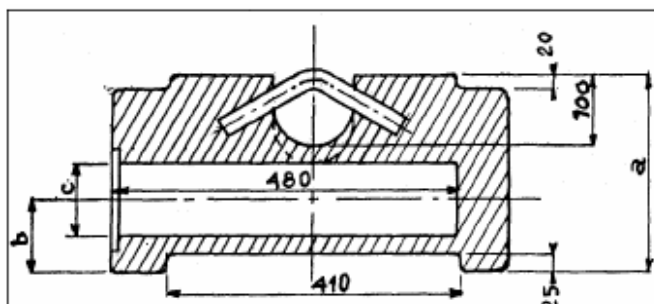

Dimensions for Some Typical High Capacity Cast Iron Weights – Variant 3

FIGURE 3/0B – 3

Rectangular Mass  
1000 kg  
Suitable for Stacking  
Dimensions (mm)

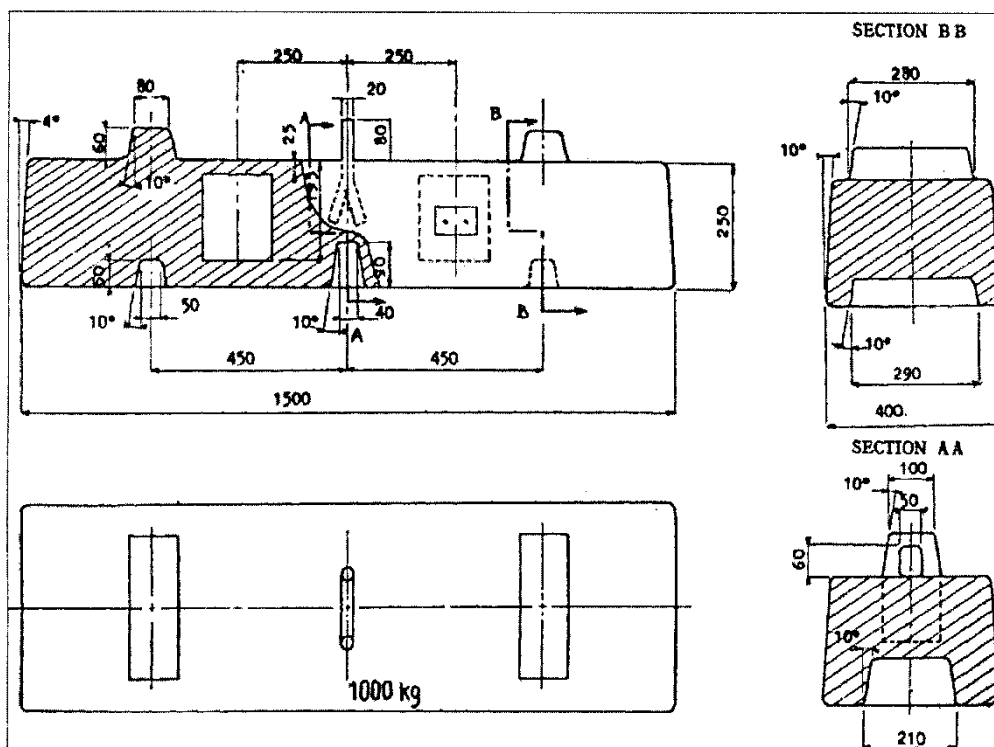

Dimensions for Another Typical High Capacity Cast Iron Mass – Variant 3

~ End of Document ~