



Australian Government  
Department of Industry,  
Science and Resources

## National Measurement Institute

36 Bradfield Road, West Lindfield NSW 2070

# Certificate of Approval

## NMI 13/1/32

Issued by the Chief Metrologist under Regulation 60  
of the  
*National Measurement Regulations 1999*

This is to certify that an approval for use for trade has been granted in respect of the instruments herein described.

SICK Model VMS5200 Dimensional Measuring Instrument

submitted by SICK Pty Ltd  
5 Helen Street  
West Heidelberg VIC 3081

**NOTE:** This Certificate relates to the suitability of the pattern of the instrument for use for trade only in respect of its metrological characteristics. This Certificate does not constitute or imply any guarantee of compliance by the manufacturer or any other person with any requirements regarding safety.

This approval has been granted with reference to document NMI R 129, *Multi-dimensional Measuring Instruments*, dated July 2004.

This approval is subject to review at the decision of the Chief Metrologist in accordance with the conditions specified in the document NMI P 106.

### DOCUMENT HISTORY

Rev	Reason/Details	Date
0	Pattern provisionally approved – interim certificate issued	01/07/19
1	Variant 1 & 2 provisionally approved – interim certificate issued	08/11/19
2	Pattern and Variant 1 & 2 approved – certificate issued	16/04/20
3	Variant 2 amended (software version) – Variant 3 to 5 approved – certificate issued	13/02/23
4	Variant 6 approved – certificate issued	20/07/23
5	Variant 7 approved – certificate issued	19/05/26

## CONDITIONS OF APPROVAL

### General

Instruments purporting to comply with this approval shall be marked with pattern approval number 'NMI 13/1/32' and only by persons authorised by the submitter.

Instruments purporting to comply with this approval and currently marked 'NMI P13/1/32' may be re-marked 'NMI 13/1/32' but only by persons authorised by the submitter.

It is the submitter's responsibility to ensure that all instruments marked with this approval number are constructed as described in the documentation lodged with the National Measurement Institute (NMI) and with the relevant Certificate of Approval and Technical Schedule. Failure to comply with this Condition may attract penalties under Section 19B of the National Measurement Act and may result in cancellation or withdrawal of the approval, in accordance with document NMI P 106.

Auxiliary devices used with this instrument shall comply with the requirements of General Supplementary Certificate No S1/0B.

### Special: For the pattern and all variants

Instruments are only approved for use for determination of the dimensions and volume of the smallest rectangular box that could contain an object, for the purposes of determining freight or postal charges.

The dimensions determined may also be used for the calculation (by peripheral equipment) of a volume and/or 'dimensional weight' (\*) value of the object, also for the purposes of determining freight or postal charges.

- (\*) A '**dimensional weight**' value is a calculated value deemed to be a weight value obtained by applying a conversion factor to the object's volume as calculated from the measured dimensions.

Signed by a person authorised by the Chief Metrologist  
to exercise their powers under Regulation 60 of the  
*National Measurement Regulations 1999*.

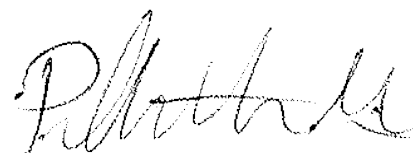

**Dr. Phillip Mitchell**  
A/g Manager  
Policy and Regulatory Services

TECHNICAL SCHEDULE No 13/1/32

**1. Description of Pattern** **provisionally approved on 01/07/19**  
**approved on 16/04/20**

A SICK model VMS5200 dimensional measuring instrument (Figures 1 and 2) which is approved for use for the determination of the linear dimensions of certain objects while they are in motion.

Instruments are approved for use over a temperature range of  $-10\text{ }^{\circ}\text{C}$  to  $+55\text{ }^{\circ}\text{C}$  and must be so marked.

**1.1 Details**

The instrument is approved for use for the determination of the linear dimensions of irregular shaped objects having maximum dimensions (i.e. length  $\times$  width  $\times$  height) of 5500 x 1600 x 1100 mm and minimum dimensions 50 x 50 x 20 mm, with a scale interval of measurement ( $d$ ) of 5 x 5 x 2 mm and a belt speed ( $V_{\max}$ ) of up to 180 m/min.

The pattern converts the detected characteristics into the linear dimensions of the smallest rectangular box (parallelepiped – #) that would fully contain the object.

The pattern is approved for use in measuring the linear dimensions of opaque objects only; the dimensions determined may also be used for the calculation of volume and/or 'dimensional weight' value (\*) of the item (refer to the Special Conditions of Approval).

- (#) A rectangular box (parallelepiped) is a polyhedron having six faces that are parallel in pairs; each face is a parallelogram and adjacent edges are perpendicular.
- (\*) A '**dimensional weight**' value is a calculated value deemed to be a weight value obtained by applying a conversion factor to the object's volume as calculated from the measured dimensions.

**1.2 Dimensioning System**

The pattern includes two SICK model LMS4000 laser dimensioning sensors (Figure 3) mounted above a belt-conveyor type load receptor.

The sensors are laser based optical scanners which measure the reflected light across the width of the measurement area and with signals from the encoder, is analysed by the SIM2000 control unit to determine the linear dimensions of the object.

**1.3 SIM2000 Control Unit**

Each dimensioning sensor is connected to a SICK model SIM2000 control unit (Figure 4) to process a three-dimensional model of the object and determine the linear dimensions that fully contain the object. The SIM2000 also provides additional digital data interfaces and supports connectivity and commissioning of the laser dimensioning sensors.

The SIM2000 operates software version 3.xx.xx

## 1.4 Speed Sensing System

With a SICK model DFV 60 wheel encoder or equivalent (\*) speed sensing system to measure the length of the object in combination with the LMS4000 sensors. The encoder is fitted to contact the conveyor belt, usually underneath where it can't be struck by packages, and generates pulses based on the displacement of the belt while the laser dimensioning head detects the object being measured.

(\*) 'Equivalent' is defined to mean other proprietary equipment of the same or better specifications requiring no changes to the software specified in this approval for satisfactory operation of the system

## 1.5 Indications

An LFT LCD display (Figure 5) is connected to the SIM2000 control unit for indication of measurement results. The indicator is also used to operate and configure the instrument and displays any error messages that occur during a measurement operation.

Indicator lamps may be fitted to signal when the system is operating, a measurement is in progress or an error has been detected.

The pattern is fitted with a display however measurement data is also made available to other systems for indication and/or printing.

Where other systems are interfaced to the instrument, printed and displayed information must be made available for verification and must comply with the requirements set out in document NMI R129, *Multidimensional Measuring Instruments*, in particular as per the extract below.

7.9.1 Any printed ticket or displayed indication shall include sufficient information to identify the transaction, for example:

- (a) dimensions: length ( $L$ ), width ( $W$ ) and height ( $H$ );
- (b) volume (vol);
- (c) weight ( $Wt$ ) if the instrument includes a weighing instrument;
- (d) dimensional weight (Dim  $Wt$  ... kg or  $DW$  ... kg);
- (e) dimensional tare ( $DT$  ... kg);
- (f) conversion factor ( $F$ );
- (g) quantity for charging, for example dimensions, vol or  $DW$  ... kg;
- (h) price rate and price; and
- (i) date, transaction number or other identification of the object.

*Note 1:* Icons may be used to identify indications.

*Note 2:* When the customer is not present during the measurement process the above information need not be displayed or printed out at the time but shall be available on request.

*Note 3:* The price interval and the price rate shall comply with the national regulations applicable for trade.

7.9.2 A printed ticket shall also contain the following printed or pre-printed information:

- (a) that the dimensions and/or volume shown are those of the smallest rectangular box that fully encloses the object; and
- (b) that the dimensional weight is a calculated value deemed to be a weight value obtained by applying a conversion factor to the object's volume or dimensions.

## 1.6 Additional System Facilities

The system may interface with other facilities such as barcode reading systems. The facilities shall not interact with the system in a way that would cause an incorrect indication of the measurement result.

## 1.7 Sealing Provision

Provision is made for sealing the calibration adjustments in the SIM2000 by preventing access to the setup ports. Provision is also made for sealing the LMS4000 sensors, the speed sensing system and the indicator by means of adhesive sealing labels. See Figure 6 for sealing positions.

## 1.8 Verification Provision

Provision is made for the application of a verification mark.

## 1.9 Descriptive Markings and Notices

- (a) Instruments carry the following markings (in the vicinity of the indicating device):

Manufacturer's mark, or name written in full	SICK Pty Ltd
Model designation	.....
Serial number of the instrument	.....
Year of manufacture	.....
Pattern approval number for the instrument	NMI P13/1/32
Maximum dimensions for each axis	<i>Max</i> ..... mm
Minimum dimensions for each axis	<i>Min</i> ..... mm
Scale interval	<i>d</i> = ..... mm
Maximum belt speed	<i>Max</i> ..... m/sec or m/min
Minimum belt speed	<i>Min</i> ..... m/sec or m/min
Special temperature limits	-10 °C to +55 °C

- (b) Instruments carry one or more notices stating CERTAIN REFLECTIVE OR TRANSPARENT ITEMS CANNOT BE MEASURED, or similar wording:

## 2. Description of Variant 1 provisionally approved on 08/11/19 approved on 16/04/20

With the encoder described in **1.4 Speed Sensing System** replaced with a SICK Optical Sensor (Figure 7). The optical sensor detects the movement of the conveyor belt and is used to measure the length of the object in combination with the dimensioning unit. The optical sensor may be used with cross belt conveyors.

**3. Description of Variant 2** **provisionally approved on 08/11/19**  
**approved on 16/04/20**  
**amended on 13/02/23**

A SICK model VMS5100 dimensional measuring instrument (Figure 8) which is similar to the pattern but comprises only a single dimensioning unit described in **1.2 Dimensioning System**.

This VMS5100 measures the linear dimensions of rectangular box-shaped (parallelepiped (#), cuboidal) objects only having maximum dimensions (i.e. length × width × height) of 5500 x 1200 x 1100 mm and minimum dimensions 50 x 50 x 20 mm, with a scale interval of measurement (*d*) of 5 x 5 x 2 mm and a belt speed ( $V_{max}$ ) of up to 180 m/min.

The VMS5100 operates software version x.11.x.0.

(#) A rectangular box (parallelepiped) is a polyhedron having six faces that are parallel in pairs; each face is a parallelogram and adjacent edges are perpendicular.

**3.1 Descriptive Markings and Notices**

In addition to the **1.9 Descriptive Markings and Notices** for the pattern, instruments of variant 2 carry one or more notices stating, 'TO BE USED FOR RECTANGULAR BOX SHAPED OBJECTS ONLY', or similar wording.

**4. Description of Variant 3** **approved on 13/02/23**

With the SICK model VMS5200 of the pattern operating a SIM2000 ST control unit and software version x.12.x.0.

**5. Description of Variant 4** **approved on 13/02/23**

A SICK model VMS5200-X dimensional measuring instrument which is similar to the pattern with the updated SIM2000 ST Control unit operating software version xx.12.x.0.

VMS5200-X may be configured with the speed sensing system of Variant 1 for use with cross belt conveyors.

**6. Description of Variant 5** **approved on 13/02/23**

With the models described in the pattern and variants operating an updated SIM2000-2 Prime control unit (Figure 9).

The SIM2000-2 Prime control unit operates the following software version for the models listed in Table 1 below:

TABLE 1 – Approved software versions

<b>Model</b>	<b>Software Version</b>
VMS5100	xx.21.x.0
VMS5200	xx.22.x.0
VMS5200-X	xx.22.x.0

## 6.1 Sealing Provision

Provision is made for sealing the calibration adjustments in the SIM2000-2 Prime control unit by preventing access to the setup ports (Figure 10).

## 7. Description of Variant 6 approved on 20/07/23

A SICK model VMS5300 dimensional measuring instrument (Figure 11) which is similar to the pattern but comprises three dimensioning units described in **1.2 Dimensioning System**.

The VMS5300 measures the linear dimensions of rectangular box-shaped or irregular shaped objects having maximum dimensions (i.e. length × width × height) of 5500 x 1600 x 1250 mm and minimum dimensions 50 x 50 x 20 mm, with a scale interval of measurement ( $d$ ) of 5 x 5 x 2 mm and a belt speed ( $V_{max}$ ) of up to 150 m/min.

The variant converts the detected characteristics into the linear dimensions of the smallest rectangular box that would fully contain the object.

The VMS5300 operates software version V24.12.x.x

VMS5300 may be configured with the speed sensing system of Variant 1 for use with cross belt conveyors.

## 8. Description of Variant 7 approved on 19/05/26

The maximum dimensions (i.e. length × width × height) may be configured to a value of less than or equal to the maximum dimensions specified for each axis of the pattern or variants.

The minimum dimensions (i.e. length × width × height) may be configured to a value of greater than or equal to the minimum dimensions specified for each axis of the pattern or variants.

The scale interval of measurement ( $d$ ) for each axis of measurement may be configured with the values shown in Table 2:

TABLE 2

Measurement Axis	Scale Interval ( $d$ )
Length	5 mm, 10 mm
Width	5 mm, 10 mm
Height	2 mm, 5 mm, 10 mm

Descriptive markings shall be updated to reflect the maximum and minimum dimension and scale interval configured for each instrument.

## TEST PROCEDURE No 13/1/32

Note: Refer to clause **1.5 Indications** – Printed and displayed information must be made available for verification and must comply with the requirements set out in document NMI R 129, *Multi-dimensional Measuring Instruments*, dated July 2004.

The instrument shall not be adjusted to anything other than as close as practical to zero error, even when these values are within the maximum permissible errors.

### Maximum Permissible Errors

The maximum permissible errors are specified in Schedule 1 of the *National Trade Measurement Regulations 2009*.

Instruments shall be tested as follows:

- (a) Test objects shall be used of known lengths such that each axis (i.e. length × width × height) is tested for at least five dimensions between and including the minimum and maximum lengths specified on the instrument nameplate. Each test object shall be rigid and with well-defined edges to simulate the edges of a rectangular box. All adjacent faces and edges shall be perpendicular to each other. The dimensions shall be equal to  $N \cdot d$  and the lengths shall be known to an uncertainty equal to or better than  $\pm 1/5$  of the maximum permissible error, which is equal to the scale interval ( $d$ ).  $N$  is a whole number.
- (b) Carry out at least three test runs for each length, varying position and orientation across the receptor. Each measurement shall be within the maximum permissible error.
- (c) Check that instruments carry one or more notices stating CERTAIN REFLECTIVE OR TRANSPARENT ITEMS CANNOT BE MEASURED, or similar wording.
- (d) Ensure that instruments are only being used within the special temperature limits stated elsewhere in this Technical Schedule.

### For instruments of Variant 2 only

- (e) Check that instruments carry one or more notices stating TO BE USED FOR RECTANGULAR BOX SHAPED OBJECTS ONLY, or similar wording.

FIGURE 13/1/32 – 1

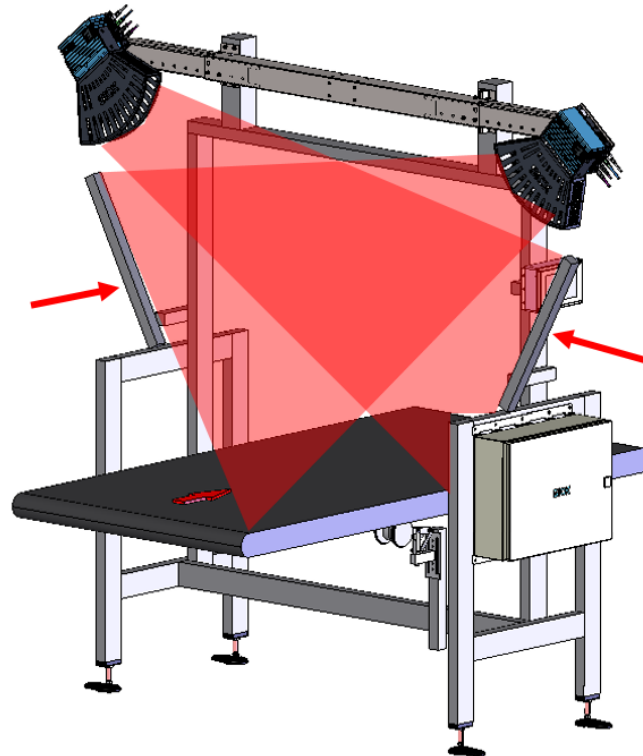

SICK Model VMS-5200 Dimensional Measuring Instrument

FIGURE 13/1/32 – 2

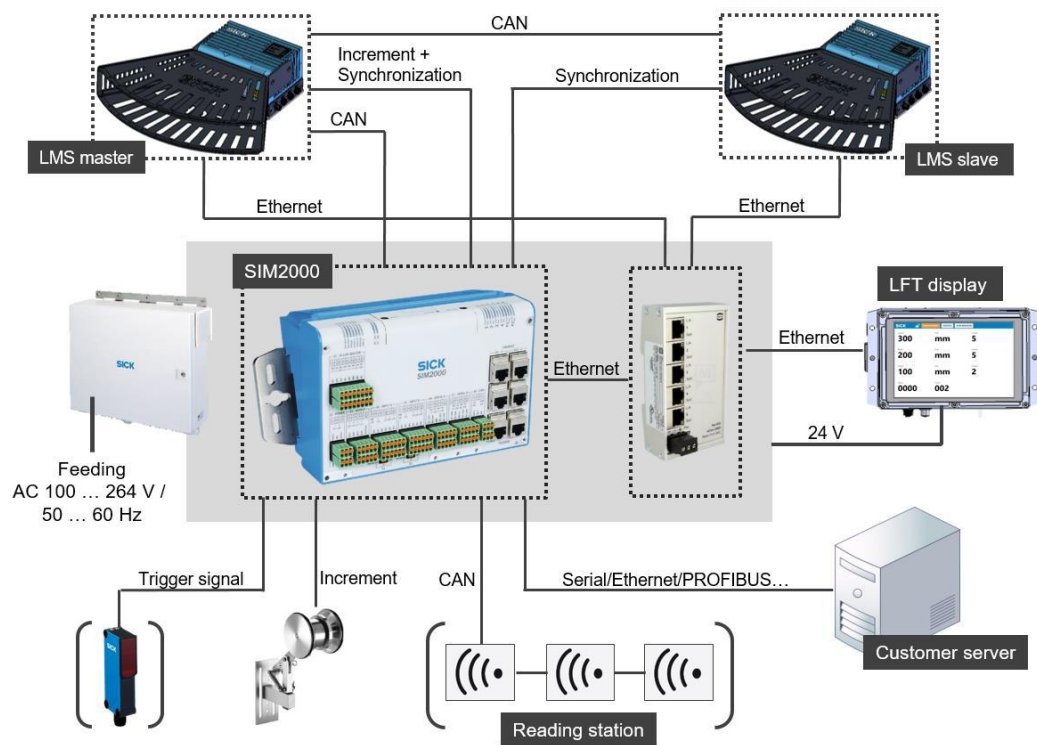

SICK Model VMS-5200 Dimensional Measuring Instrument

FIGURE 13/1/32 – 3

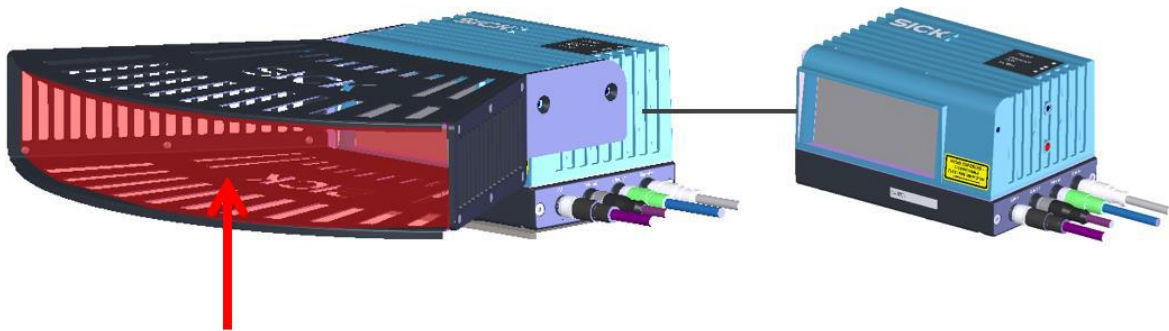

SICK model LMS4000 laser dimensioning sensors

FIGURE 13/1/32 – 4

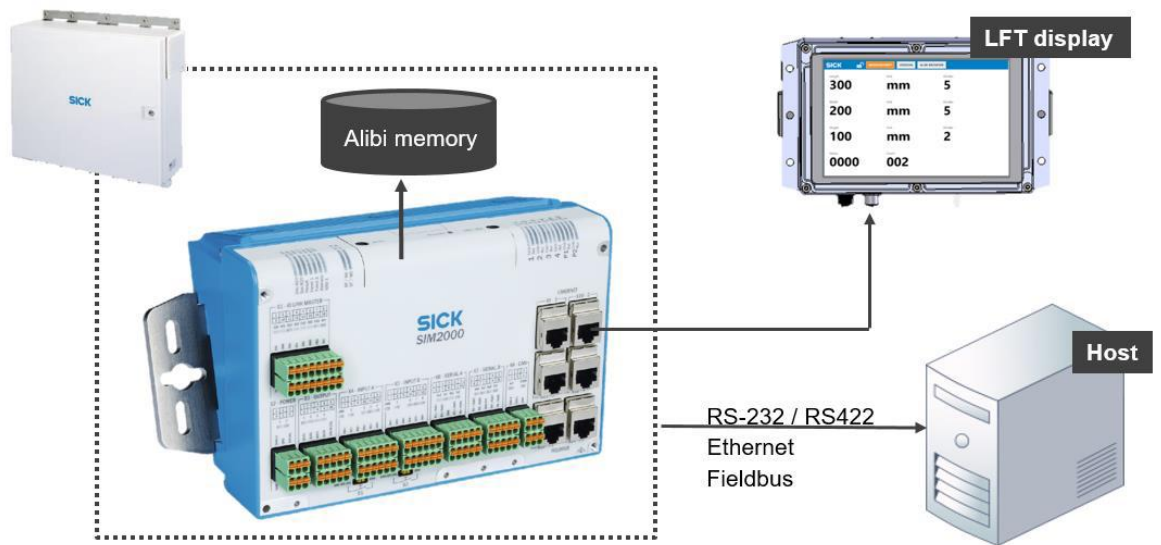

SICK model SIM2000 control unit

FIGURE 13/1/32 – 5

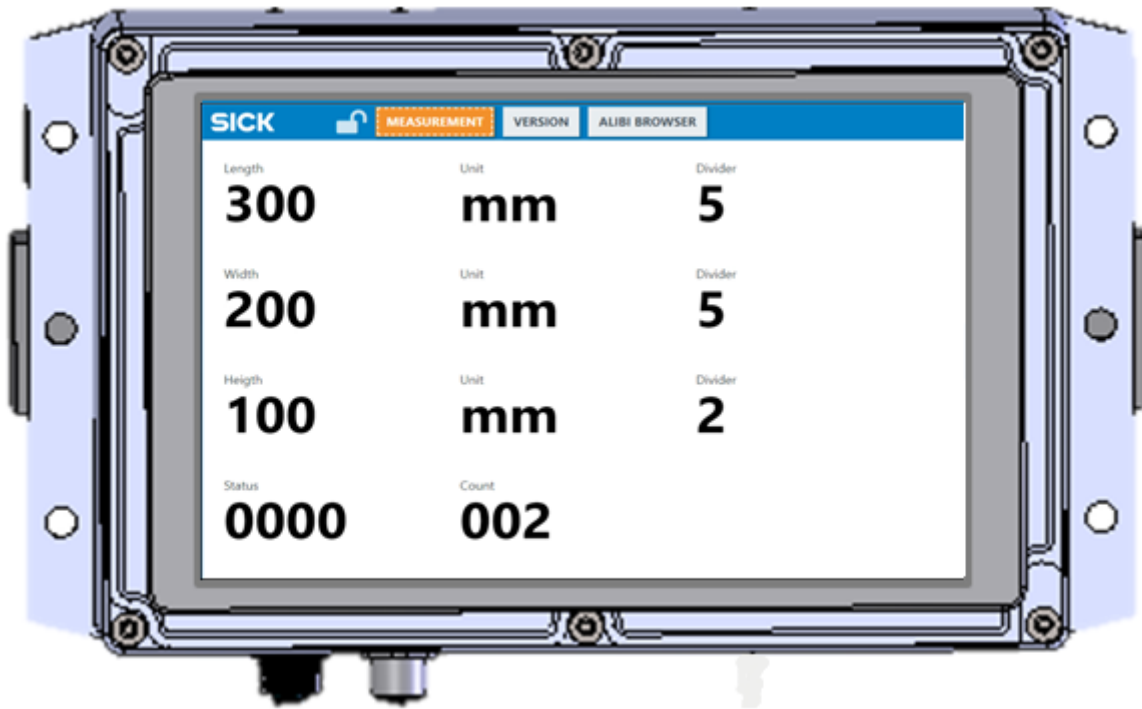

LFT LCD display

FIGURE 13/1/32 – 6

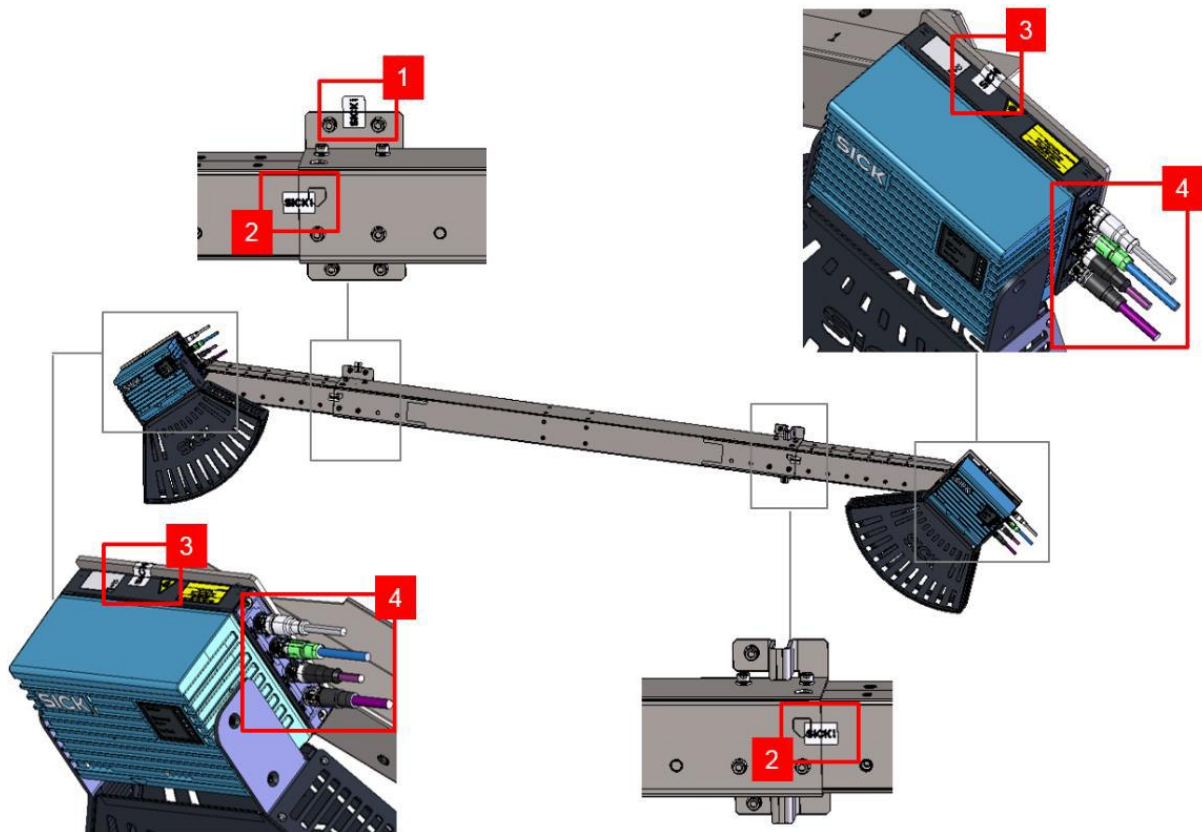

(a) Typical Sealing Locations

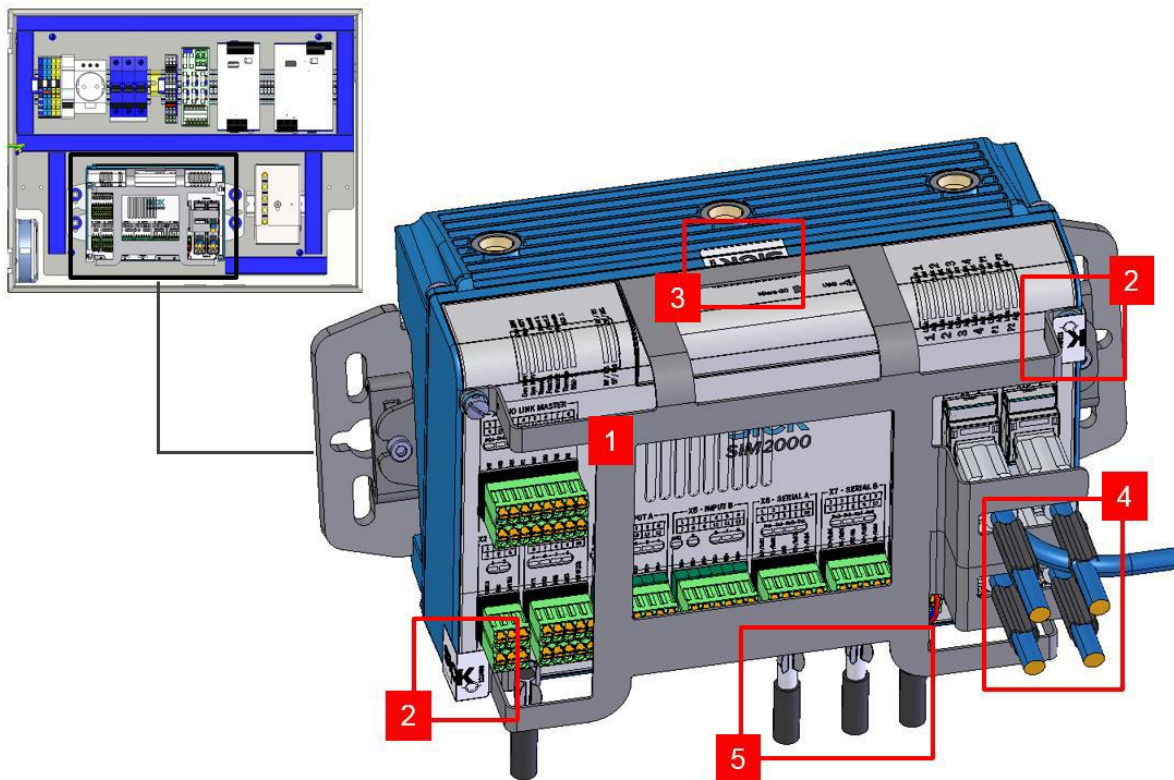

(b) Typical Sealing Locations

FIGURE 13/1/32 – 6 continued

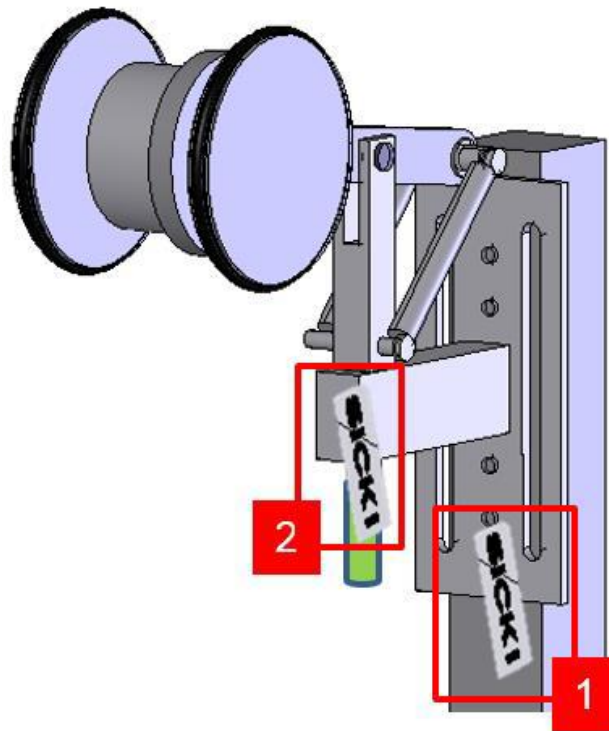

(c) Typical Sealing Locations

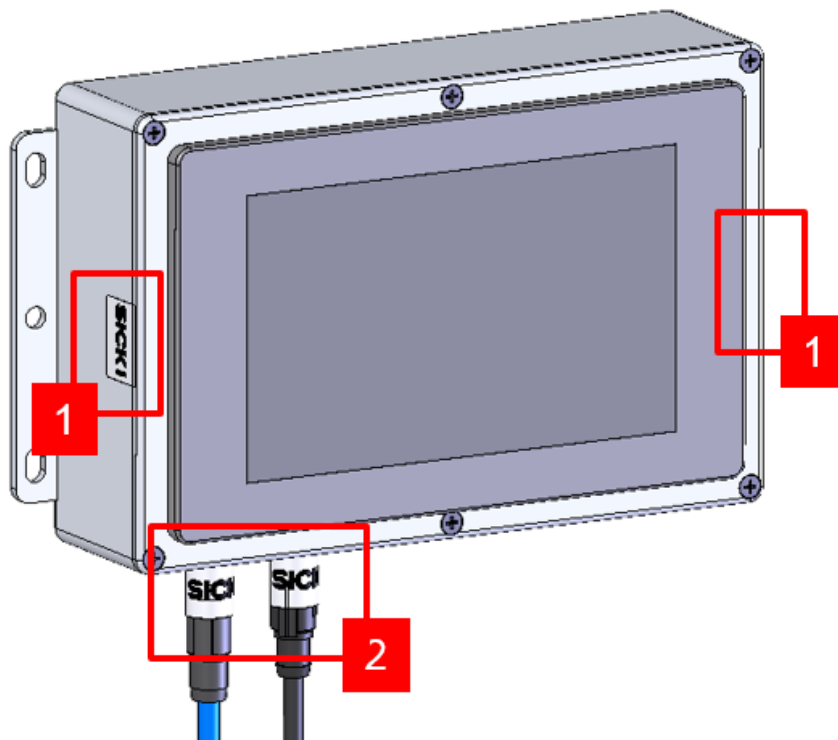

(d) Typical Sealing Locations

FIGURE 13/1/32 – 7

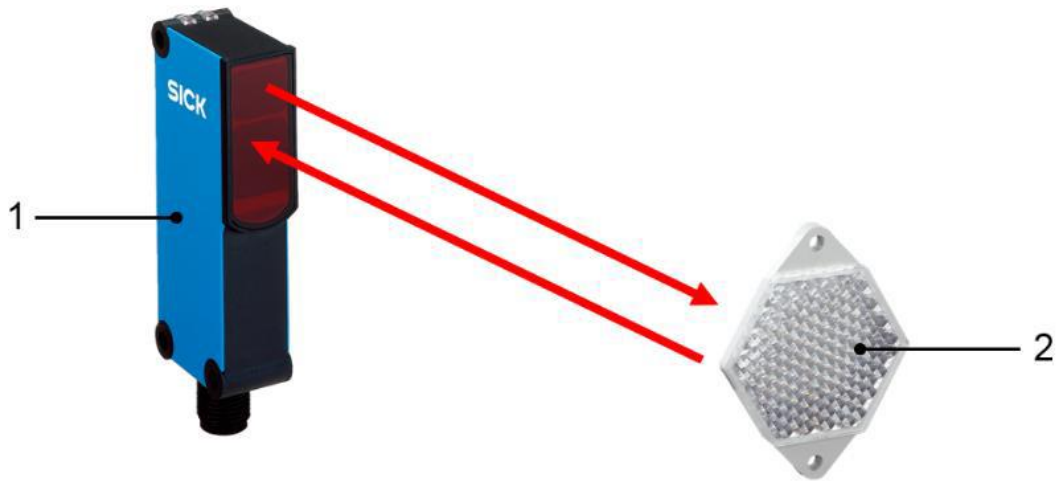

SICK Optical Sensor Speed Sensing System (Variant 1)

FIGURE 13/1/32 – 8

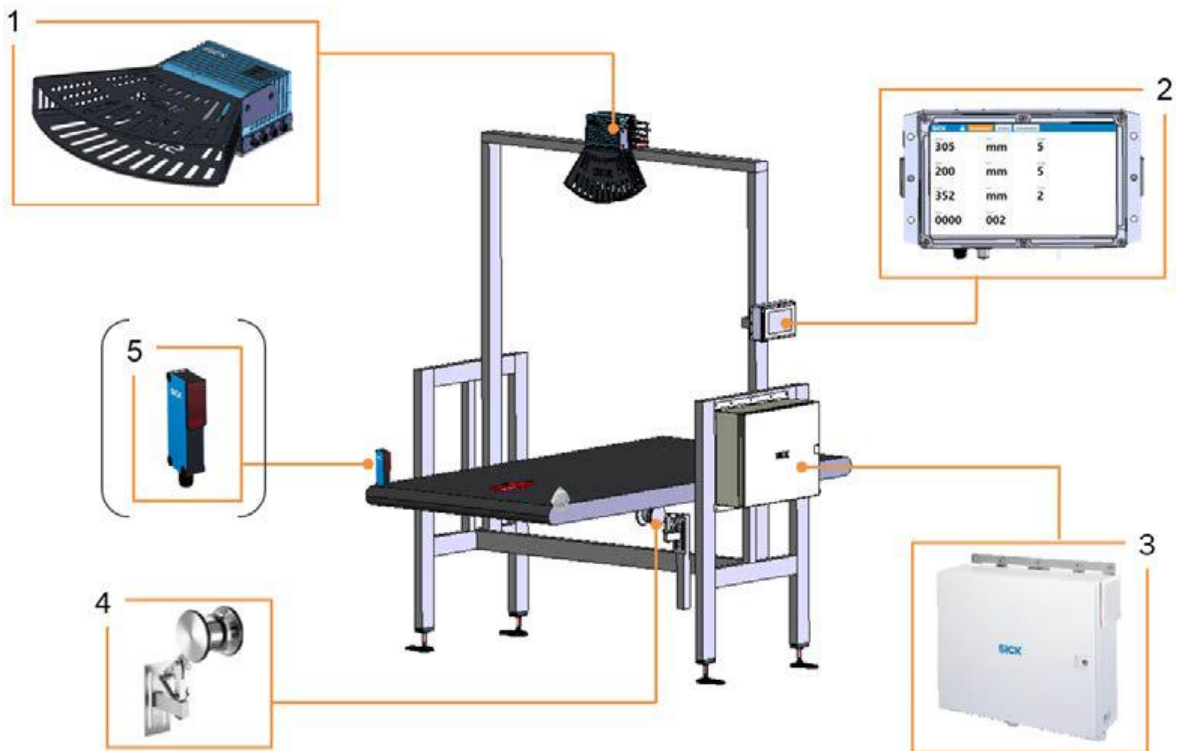

SICK model VMS5100 dimensional measuring instrument (Variant 2)

FIGURE 13/1/32 – 9

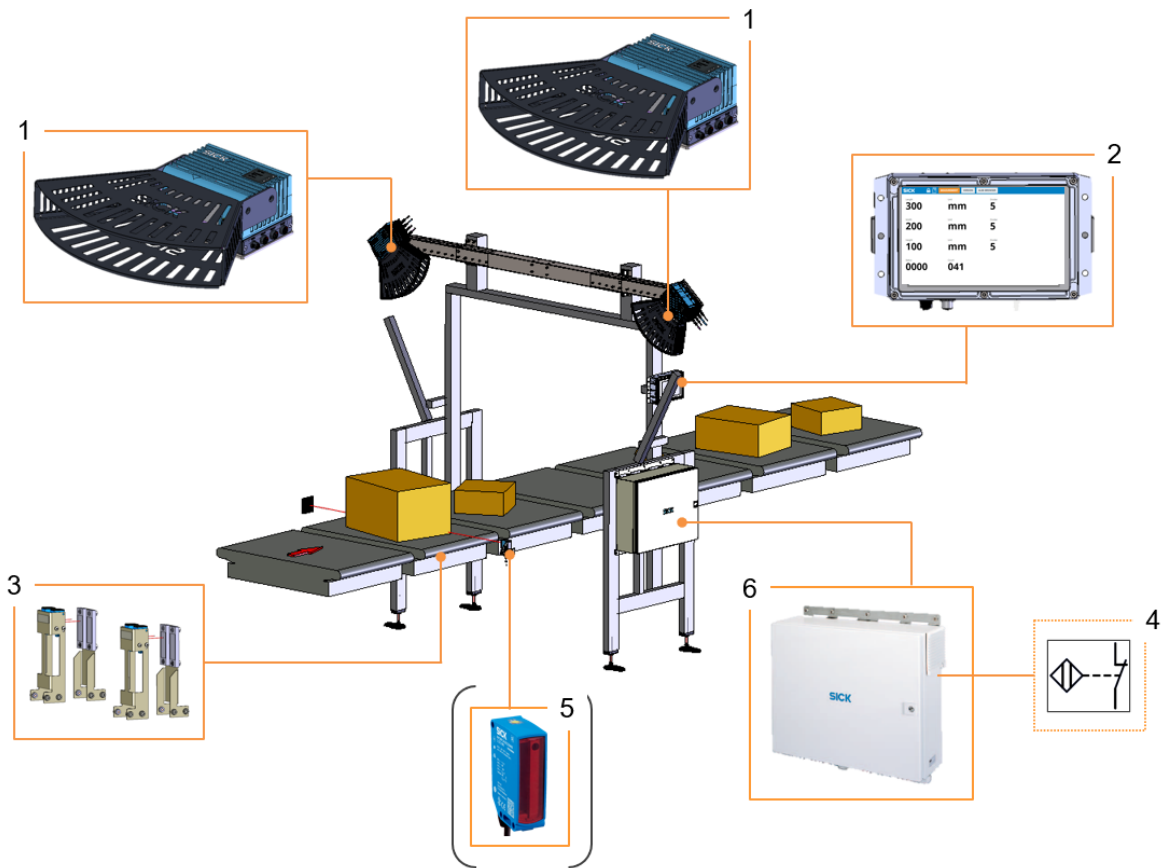

SICK model VMS5200-X dimensional measuring instrument with SIM2000-2 Prime control unit (Variant 4)

FIGURE 13/1/32 – 10

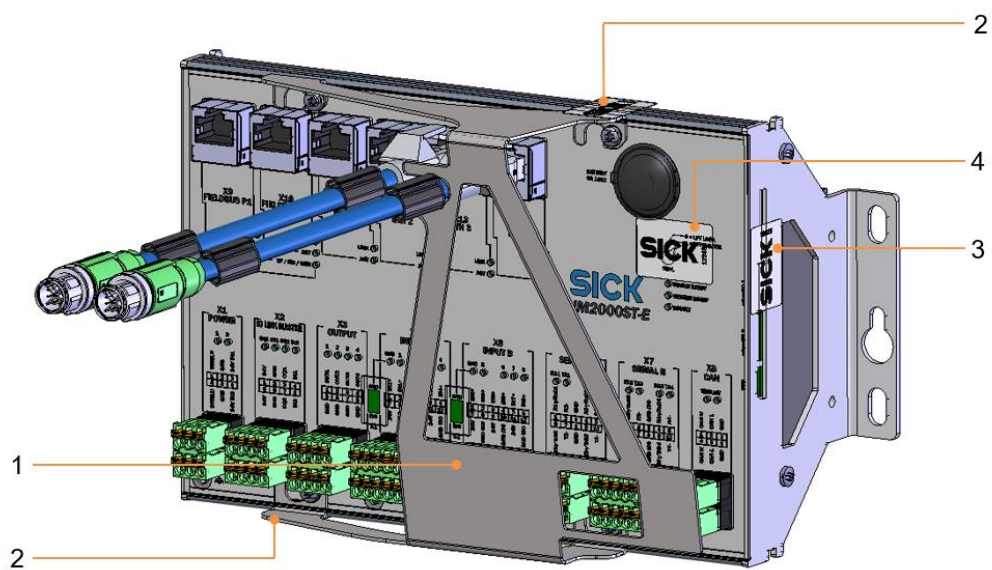

(a) Typical Sealing Locations of the SIM2000-2 Prime control unit (Variant 5)

FIGURE 13/1/32 – 11

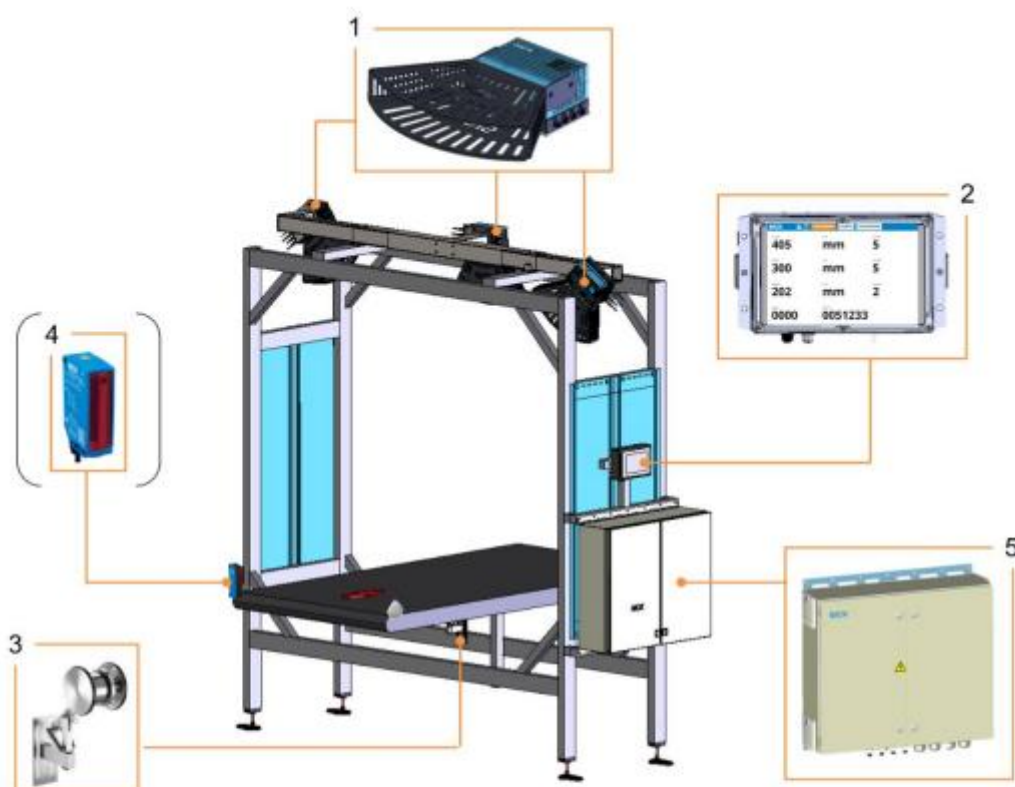

Fig. 1: Components of the VMS4300/5300

---

Legend

- 1 LMS4x21 2D LiDAR sensor with laser protective cover
  - 2 LFT display - VMS5300 only
  - 3 Incremental encoder (e.g., DFV60)
  - 4 Trigger photoelectric sensor for triggered systems (e.g., RAY26)
  - 5 Cabinet with a system controller, dimensioning controller, power supply units, and Ethernet switch
- 

a) SICK model VMS5300 dimensional measuring instrument (Variant 6)

FIGURE 13/1/32 – 11 continued

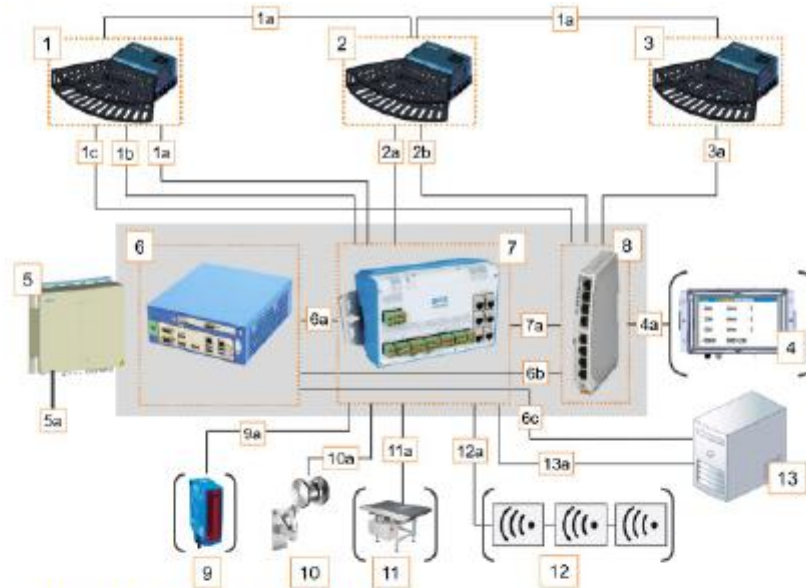

Fig. 66: Connection overview for the VMS4300/5300

Legend

- 1 2D LIDAR sensor (master)**
- 1a CAN bus
- 1b Increment and synchronization
- 1c Ethernet
- 2 2D LIDAR sensor (slave)**
- 2a Synchronization
- 2b Ethernet
- 3 2D LIDAR sensor (slave)**
- 3a Ethernet
- 4 LFT display - VMS5300 only**
- 4a Ethernet
- 5 Cabinet**
- 5a Feed 100 ... 264 V AC / 50 ... 60 Hz
- 6 APU8520 dimensioning controller**
- 6a CAN bus
- 6b Ethernet
- 6c not legally relevant output of the 3D point cloud (Eth.client/non-interacting)
- 7 SIM2000 system controller**
- 7a Ethernet
- 8 Ethernet switch**
- 9 Trigger photoelectric retro-reflective sensor (optional)**
- 9a Trigger signal
- 10 Incremental encoder**
- 10a Incremental signal
- 11 Weighing station (optional)**
- 11a Data connection
- 12 Reading station (optional)**
- 12a CAN bus
- 13 Customer server**
- 13a Data output via Ethernet, fieldbus, or serial connection

b) SICK model VMS5300 dimensional measuring instrument – Connection Overview (Variant 6)

~ End of Document ~