



Australian Government

Department of Industry,  
Science and Resources

**National  
Measurement  
Institute**

36 Bradfield Road, West Lindfield NSW 2070

**Certificate of Approval**  
**NMI 14/3/46**

Issued by the Chief Metrologist under Regulation 60  
of the  
National Measurement Regulations 1999

This is to certify that an approval for use for trade has been granted in respect of the instruments herein described.

ABB AquaMaster4 Model Water Meter

submitted by    ABB Limited  
                         Oldends Lane  
                         Stonehouse Gloucestershire GL10 3TA  
                         United Kingdom

**NOTE:** This Certificate relates to the suitability of the pattern of the instrument for use for trade only in respect of its metrological characteristics. This Certificate does not constitute or imply any guarantee of compliance by the manufacturer or any other person with any requirements regarding safety.

This approval has been granted with reference to document NMI R 49-1 Water Meters Intended for the Metering of Cold Potable Water and Hot Water, *Part 1 Metrological and Technical Requirements*, dated May 2022 and NMI M 10-1 Meters Intended for the Metering of Water in Full Flowing Pipes, *Part 1 Metrological and Technical Requirements*, dated July 2010.

This approval is subject to review at the decision of the Chief Metrologist in accordance with the conditions specified in the document NMI P 106.

DOCUMENT HISTORY

Rev	Reason/Details	Date
0	Pattern & Variants 1, 2 & 3 approved – certificate issued	03/10/19
1	Pattern & Variants 1 to 3 reviewed (various), Variants 4 to 7 approved – certificate issued	25/03/22
2	Pattern amended (software versions) – certificate issued	24/10/22

Rev	Reason/Details	Date
3	Pattern & Variant 1 amended (model numbers and software versions), Variants 4 & 5 amended (meter size and flowrate) – certificate issued	15/03/24
4	Pattern and Variant 1 amended (communications and software versions), Variants 2, 3, 4 & 5 amended (power supply options) – certificate issued	13/05/26

## CONDITIONS OF APPROVAL

### General

Instruments purporting to comply with this approval shall be marked with pattern approval number 'NMI 14/3/46' and only by persons authorised by the submittor.

It is the submittor's responsibility to ensure that all instruments marked with this approval number are constructed as described in the documentation lodged with the National Measurement Institute (NMI) and with the relevant Certificate of Approval and Technical Schedule. Failure to comply with this Condition may attract penalties under Section 19B of the National Measurement Act and may result in cancellation or withdrawal of the approval, in accordance with document NMI P 106.

Signed by a person authorised by the Chief Metrologist to exercise their powers under Regulation 60 of the *National Measurement Regulations 1999*.

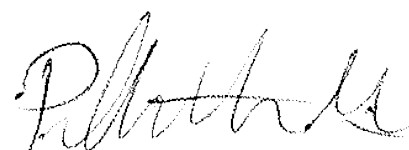

**Phillip Mitchell**  
A/g Manager  
Policy and Regulatory Services

TECHNICAL SCHEDULE No 14/3/46

**1. Description of Pattern**

**approved on 03/10/19  
amended on 25/03/22  
amended on 24/10/22  
amended on 15/03/24  
amended on 13/05/26**

An ABB AquaMaster4 DN40 water meter intended for the metering of cold potable and non-potable water.

**1.1 Field of Operation**

The field of operation of the measuring system using the ABB AquaMaster4 DN40 model water meter is determined by the following characteristics:

Minimum flow rate, Q <sub>1</sub>	0.0625 m <sup>3</sup> /h
Transition flow rate, Q <sub>2</sub>	0.10 m <sup>3</sup> /h
Maximum continuous flow rate, Q <sub>3</sub> :	25.00 m <sup>3</sup> /h
Overload flow rate, Q <sub>4</sub>	31.25 m <sup>3</sup> /h
Flow rate ratio, Q <sub>3</sub> /Q <sub>1</sub> :	400
Maximum admissible water temperature:	50 °C
Temperature Class:	T50
Ambient air temperature range:	-25 °C to +55 °C
Maximum admissible pressure:	1600 kPa
Pressure loss class:	Δp40
Accuracy class:	1, 2 or 2.5
Flow profile sensitivity class:	U0/D0 – see table 1
Electromagnetic class:	E1 (residential) or E2 (industrial)
Environmental class:	B or O (indoor & outdoor)
Orientation:	All positions
Flow Direction:	Forward/reverse
Power supply:	Battery powered: 2 x 3.6 V (operating range: 2.9 – 3.6 V)

## 1.2 Features/Functions

The ABB AquaMaster4 DN40 model water meter (Figure 1 and 2) consists of a reduced bore, rubber lined ABB electromagnetic flow sensor (FEW411.R) connected to an ABB AquaMaster4 model signal transmitter (FET411).

Note: See Variant 1 for more information and options regarding the model designations and configurations of the flow sensor and signal transmitter. Software variants (clause 1.4) were additionally introduced with reduced interface functionality and removal of pressure measurement options.

Connection type: Flanged

Display: The signal transmitter incorporates an electronic calculator and indicating device (Figure 2) capable of providing a maximum display of 999 999 999 m<sup>3</sup>. The indicating device incorporates a programmable decimal point position, allowing the maximum display to be adjusted based upon the value of Q<sub>3</sub>. In all cases the value of the maximum display shall comply with the requirements of NMI R 49-1. The indicating device can be switched to display in litres (L), allowing for a verification scale interval of 0.01 L.

Communications<sup>(1)</sup>: Pulse, RS485, RTU Modbus, Sensus protocol

Materials: Flow sensor: Epoxy coated stainless steel

Flow converter: Polymer material

Meter length: 200 mm

<sup>(1)</sup> The pattern and variants may be fitted and/or configured with the communication options listed in this Certificate. However, the primary indication of volume displayed by the indicating device of the meter is the approved indication of volume.

### 1.3 Conditions

#### 1.3.1 Installation Conditions

No flow straightener or flow conditioner is required.

For accuracy class 1 and 2, the flow profile sensitivity class is U0/D0.

For accuracy class 2.5, the installation conditions are specified in Table 1.

**Table 1 Minimum pipe lengths required by flow disturbance type**

Flow Sensor	Disturbance Type (*)	Minimum number of upstream pipe lengths (DN)	Minimum number of downstream pipe lengths (DN)
FEW4XY.R	1	0	0
	2	0	0
	3	0	0

(\*) For information on the different types of flow disturbances which are examined as part of pattern approval, refer to NMI M 10-2.

#### 1.3.2 Specified Installations and Open Channel Emplacements (Accuracy Class 2.5)

The meter (pattern and variants) has not been tested or evaluated for performance in specified installations or open channel emplacements as part of this approval.

More information regarding specified installation and open channel emplacement testing may be found in NMI M 10-1 and NMI M 10-2.

#### 1.3.3 Water Quality

The meter is approved for use in the metering of potable water supplies.

The meter is approved for use in the metering of non-potable water supplies.

The meter is approved for use in water with conductivity > 50  $\mu\text{S/cm}$

## 1.4 Software Version

The Pattern and Variants are approved with the software versions specified in Tables 2.a, 2.b, and 2.c below.

**Table 2.a Software Versions**

Software Part Code	Software version	Checksum	Remarks
3KXF004476U0113	01.00.15	0xBD1C4895	NA
3KXF208402U0113	03.00.03	B26AFE6B	Full functionality
	03.00.04	6E98963A	Full functionality
	03.02.00	E12E5C04	Full functionality
	03.03.02	D4D1E40B	Full functionality
	03.03.03	CEEF45F1	Full functionality
	03.03.06	DAC51328	Improvements to electrode resistance calculations.
	03.04.00	277BA336	Improvements to sensor diagnostics.
	03.04.02	66624063	RTC Bug fix & update to Modbus registers
3KXF208402U0313	02.00.02	84EBD1C8	Reduced functionality without pressure measurement, logger or Sensus communications.
	02.00.03	D93FDB0F	Reduced functionality as above. Improvements to electrode resistance calculations
	02.00.04	5D2D2DDD	RTC Bug fix & update to Modbus registers

**Table 2.b Software Versions**

<b>Software Part Code</b>	<b>Software version</b>	<b>Checksum</b>	<b>Remarks</b>
3KXF208402U0513	02.00.01	C28EAA16	Reduced functionality without pressure measurement, Modbus communications.
	02.00.02	9F333FBC	Reduced functionality as above. Improvements to electrode resistance calculations
	02.00.05	F517559F	RTC Bug fix & update to Modbus registers

**Table 2.c Software Versions for Aquamaster FEW45Y.Z**

<b>Software version</b>	<b>Checksum</b>	<b>Remarks</b>
Measurement		
01.03.03	2358C8FF	Software identification for Measurement MCU Supports mobile communications on FEW45Y.Z / FET45Y models
4G		
01.05.03	EC5B9ED3	Software identification for Communications MCU Supports mobile communications on FEW45Y.Z / FET45Y models

## **1.5 Verification Provision**

Provision is made for the application of a verification mark.

## **1.6 Sealing Provision**

### **1.6.1 Software**

To prevent unauthorised modification of any legally relevant metrological parameter the transmitter must be put into “metrological read-only” mode, via the activation of the “read-only” switch (Figure 3). A suitable anti-tamper seal shall be fitted (Figure 4) such that, in the event of unauthorized tampering, it is clearly evident that the fitted legal metrology seal has been broken.

The physical memory within both the transmitter and sensor are buried with potting such that attempts to swap the memory would result in evidence of damage to the meter.

### **1.6.2 Hardware**

The flow sensor is sealed to the transmitter via the application of physical seals such that any attempts to access metrologically significant components is made clearly evident.

## 1.7 Descriptive Markings and Notices

Instruments are marked with the following data, either grouped or distributed on the casing, the indicating device dial or an identification plate (Figure 5):

Manufacturer's name or mark	...
Serial number	...
Pattern approval number	NMI 14/3/46
Numerical value of maximum continuous flow rate, $Q_3$ ...	
Flow rate ratio, $Q_3/Q_1$	...
Unit of measurement	$m^3$
Temperature class <sup>(1)</sup>	T50
Maximum admissible pressure <sup>(2)</sup>	1600 kPa
Maximum pressure loss <sup>(3)</sup>	40 kPa or $\Delta p_{40}$
Orientation <sup>(4)</sup>	...
Flow profile sensitive class <sup>(5)</sup>	U0/D0
Direction of flow	→ or similar
Accuracy class <sup>(6)</sup>	1, 2 or 2.5

<sup>(1)</sup> Optional for Class T30

<sup>(2)</sup> Optional for meters with MAP of 1400 kPa or 600 kPa for  $DN \geq 500$

<sup>(3)</sup> Optional for Class  $\Delta p_{63}$

<sup>(4)</sup> Optional for meters approved for all orientations

<sup>(5)</sup> Optional for U0/D0 meters

<sup>(6)</sup> Optional for class 2 meters

For instruments that incorporate electronic devices, the following information can either be physically marked on the instrument or provided electronically via the indicating device or similar means:

Electromagnetic class	E1 or E2
Environmental class	B or O
For meters with an external power supply	the voltage and frequency
For battery powered meters	a replacement date or similar indication of expected battery life

## 2. Description of Variant 1

**approved on 03/10/19**  
**amended on 25/03/22**  
**amended on 15/03/24**  
**amended on 13/05/26**

The Pattern and Variants are approved in both compact and remote arrangements (Figure 6).

The model designation of the ABB electromagnetic flow sensor is FEW4XY.Z.

Where: X is either: 1 (standard), 3 (advanced), or 5 (premium - mobile communications)

Y is either: 1 (compact), 2 (remote) or 8 (remote sensor)

Z is either: R (reduced bore, rubber lined), V (virtual full bore, polypropylene lined) or F (full bore, elastomer lined).

The model designation of the ABB AquaMaster4 signal transmitter is FET4XY.

Where: X is either: 1 (standard), 3 (advanced), or 5 (premium - mobile communications)

Y is either: 1 (compact), 2 (remote) or 8 (remote transmitter)

In the compact arrangement, the signal transmitter is connected to the flow sensor as an integral unit.

In the remote arrangement, the flow sensor and signal transmitter are housed separately and connected via a cable with a maximum length of 150 metres. The remote arrangement incorporates alternative physical seals (Figure 7).

In the remote arrangement components that are described with either the model designations of 2 (remote) or 8 (remote sensor/transmitter) are identical except for the model number.

### 3. Description of Variant 2

**approved on 03/10/19**  
**amended on 25/03/22**  
**amended on 13/05/26**

The Pattern and Variants are approved with the battery/renewable energy powered FEW4XY.R (reduced bore, rubber lined) flow sensor (Figure 8) with the different sensor sizes, accuracy classes, flowrates and associated characteristics as specified in Tables 3 to 6.

**Table 3 Reduced bore flow sensor – battery/renewable energy powered**

Flow sensor size	Accuracy class	Q <sub>1</sub> (m <sup>3</sup> /h)	Q <sub>2</sub> (m <sup>3</sup> /h)	Q <sub>3</sub> (m <sup>3</sup> /h)	Q <sub>4</sub> (m <sup>3</sup> /h)	Ratio Q <sub>3</sub> /Q <sub>1</sub>
DN40	1 & 2	0.0625	0.1	25	31.25	400
	2.5	0.1	-	25	31.25	250
DN50	1 & 2	0.1	0.16	40	50	400
	2.5	0.16	-	40	50	250
DN65	1	0.39375	0.63	63	78.75	160
	2	0.1575	0.252	63	78.75	400
	2.5	0.252	-	63	78.75	250
DN80	1	0.625	1.0	100	125	160
	2	0.25	0.4	100	125	400
	2.5	0.4	-	100	125	250
DN100	1	1.0	1.6	160	200	160
	2	0.4	0.64	160	200	400
	2.5	0.64	-	160	200	250
DN125	1	1.0	1.6	160	200	160
	2	0.4	0.64	160	200	400
	2.5	0.64	-	160	200	250

**Table 4 Reduced bore flow sensor – battery/renewable energy powered**

<b>Flow sensor size</b>	<b>Accuracy class</b>	<b>Q<sub>1</sub> (m<sup>3</sup>/h)</b>	<b>Q<sub>2</sub> (m<sup>3</sup>/h)</b>	<b>Q<sub>3</sub> (m<sup>3</sup>/h)</b>	<b>Q<sub>4</sub> (m<sup>3</sup>/h)</b>	<b>Ratio Q<sub>3</sub>/Q<sub>1</sub></b>
DN150	1 & 2	1.0	1.6	400	500	400
	2.5	1.6	-	400	500	250
DN200	1 & 2	1.575	2.52	630	787.5	400
	2.5	2.52	-	630	787.5	250
DN250	1	6.25	10	1000	1250	160
	2	2.5	4	1000	1250	400
	2.5	4	-	1000	1250	250
DN300	1	10	16	1600	2000	160
	2	4	6.4	1600	2000	400
	2.5	6.4	-	1600	2000	250
DN350	1	10	16	1600	2000	160
	2	4	6.4	1600	2000	400
	2.5	6.4	-	1600	2000	250
DN400	1	15.625	25	2500	3125	160
	2	12.5	20	2500	3125	200
	2.5	20	-	2500	3125	125
DN450	1	15.625	25	2500	3125	160
	2	12.5	20	2500	3125	200
	2.5	20	-	2500	3125	125

**Table 5 Reduced bore flow sensor – battery/renewable energy powered**

Flow sensor size	Accuracy class	Q <sub>1</sub> (m <sup>3</sup> /h)	Q <sub>2</sub> (m <sup>3</sup> /h)	Q <sub>3</sub> (m <sup>3</sup> /h)	Q <sub>4</sub> (m <sup>3</sup> /h)	Ratio Q <sub>3</sub> /Q <sub>1</sub>
DN500	1	100	160	4000	5000	40
	2	40	64	4000	5000	100
	2.5	63.5	-	4000	5000	63
DN600	1	157.5	252	6300	7875	40
	2	63	100.8	6300	7875	100
	2.5	100	-	6300	7875	63

Alternative flowrate values may be selected under the following conditions:

- Values of Q<sub>3</sub> shall not be greater than those specified in Tables 3, 4 & 5;
- Values of Q<sub>1</sub> shall not be less than those specified in Tables 3, 4 & 5;
- The ratio Q<sub>4</sub>/Q<sub>3</sub> shall be 1.25;
- For accuracy class 1 and 2, the ratio of Q<sub>2</sub>/Q<sub>1</sub> shall be 1.6;
- For accuracy class 1 and 2, the ratio of Q<sub>3</sub>/Q<sub>1</sub> shall be not less than 40 and shall be selected as per clause 4.1.4 of NMI R 49-1; and
- For accuracy class 2.5, the ratio of Q<sub>3</sub>/Q<sub>1</sub> shall be selected as per clause 3.1 of NMI M 10-1.

The Pattern and Variants incorporating the battery/renewable energy powered FEW4XY.R flow sensor have the following installation conditions:

- No flow straightener or flow conditioner is required.
- For accuracy class 1 and 2, the flow profile sensitivity class is U0/D0.
- For accuracy class 2.5, the installation conditions are specified in Table 1 (see 1.3.1. above).

The Pattern and Variants incorporating the battery/renewable energy powered FEW4XY.R flow sensor have the following power supply options:

When X is either 1 (standard) or 3 (advanced):

- Renewable energy power (DC powered): 6 V – 32 V
- Battery power: 2 x 3.6 V (operating range: 2.9 V – 3.6 V)

When X is 5 (premium - mobile communications)

- Renewable energy power (DC powered): 6 V – 32 V including 4 x 3.6 V replaceable batteries (operating range: 2.9 V – 3.6 V)
- Battery power: 6 x 3.6 V replaceable batteries (operating range: 2.9 V - 3.6 V).

The Pattern and Variants are approved with the following pressure loss classes based upon flow sensor size and type:

Reduced bore:

- For sizes DN40 and DN50:  $\Delta p_{40}$  (40 kPa)
- For sizes DN65 to DN600:  $\Delta p_{63}$  (63 kPa)

**Table 6 Flow sensor sizes, length and verification scale interval**

Flow sensor size	Meter length (mm)	Verification scale interval (m <sup>3</sup> )
DN40 & DN50	200	0.0001
DN65	200	0.001
DN80	200	
DN100 & DN125	250	
DN150	300	
DN200	350	0.01
DN250	450	
DN300	500	
DN350	550	
DN400	600	
DN450	700	
DN500	770	0.1
DN600	920	

#### 4. Description of Variant 3

**approved on 03/10/19**  
**amended on 25/03/22**  
**amended on 13/05/26**

The Pattern and Variants are approved with the AC mains powered FEW4XY.R (reduce bore, rubber lined) flow sensor, with the different sensor sizes, accuracy classes, flowrates and associated characteristics as specified in Tables 7 to 9.

AC mains power supply: 85-240 VAC @ 50/60 Hz (with internal battery back-up):

- When X is either 1 (Standard) or 3 (Advanced): 2 x 3.6 V (operating range: 2.9 V – 3.6 V)
- When X is 5 (premium - mobile communications): 4 x replaceable batteries with operating range 2.9 V to 3.6 V)

**Table 7 Reduced bore flow sensor – AC mains powered**

Flow sensor size	Accuracy class	Q <sub>1</sub> (m <sup>3</sup> /h)	Q <sub>2</sub> (m <sup>3</sup> /h)	Q <sub>3</sub> (m <sup>3</sup> /h)	Q <sub>4</sub> (m <sup>3</sup> /h)	Ratio Q <sub>3</sub> /Q <sub>1</sub>
DN40	1	0.05	0.08	25	31.25	500
	2	0.025	0.04	25	31.25	1000
	2.5	0.04	-	25	31.25	630
DN50	1	0.08	0.128	40	50	500
	2	0.04	0.064	40	50	1000
	2.5	0.063	-	40	50	630
DN65	1 & 2	0.063	0.1008	63	78.75	1000
	2.5	0.1	-	63	78.75	630
DN80	1 & 2	0.1	0.16	100	125	1000
	2.5	0.159	-	100	125	630
DN100	1	0.32	0.512	160	200	500
	2	0.16	0.256	160	200	1000
	2.5	0.254	-	160	200	630
DN125	1	0.32	0.512	160	200	500
	2	0.16	0.256	160	200	1000
	2.5	0.254	-	160	200	630
DN150	1 & 2	0.4	0.64	400	500	1000
	2.5	0.63	-	400	500	630
DN200	1 & 2	0.63	1.008	630	787.5	1000
	2.5	1.0	-	630	787.5	630

**Table 8 Reduced bore flow sensor – AC mains powered**

Flow sensor size	Accuracy class	Q <sub>1</sub> (m <sup>3</sup> /h)	Q <sub>2</sub> (m <sup>3</sup> /h)	Q <sub>3</sub> (m <sup>3</sup> /h)	Q <sub>4</sub> (m <sup>3</sup> /h)	Ratio Q <sub>3</sub> /Q <sub>1</sub>
DN250	1	2.0	3.2	1000	1250	500
	2	1.0	1.6	1000	1250	1000
	2.5	1.59	-	1000	1250	630
DN300	1	3.2	5.12	1600	2000	500
	2	1.6	2.56	1600	2000	1000
	2.5	2.54	-	1600	2000	630
DN350	1	3.2	5.12	1600	2000	500
	2	1.6	2.56	1600	2000	1000
	2.5	2.54	-	1600	2000	630
DN400	1 & 2	5.0	8.0	2500	3125	500
	2.5	7.94	-	2500	3125	315
DN450	1 & 2	5.0	8.0	2500	3125	500
	2.5	7.94	-	2500	3125	315
DN500	1	8.0	12.8	4000	5000	500
	2	4.0	6.4	4000	5000	1000
	2.5	6.35	-	4000	5000	630
DN600	1	12.6	20.16	6300	7875	500
	2	6.3	10.08	6300	7875	1000
	2.5	10.0	-	6300	7875	630

Alternative flowrate values may be selected under the following conditions:

- Values of Q<sub>3</sub> shall not be greater than those specified in Tables 7 & 8;
- Values of Q<sub>1</sub> shall not be less than those specified in Tables 7 & 8;
- The ratio Q<sub>4</sub>/Q<sub>3</sub> shall be 1.25;
- For accuracy class 1 and 2, the ratio of Q<sub>2</sub>/Q<sub>1</sub> shall be 1.6;
- For accuracy class 1 and 2, the ratio of Q<sub>3</sub>/Q<sub>1</sub> shall be not less than 40 and shall be selected as per clause 4.1.4 of NMI R 49-1; and
- For accuracy class 2.5, the ratio of Q<sub>3</sub>/Q<sub>1</sub> shall be selected as per clause 3.1 of NMI M 10-1.

The Pattern and Variants incorporating the AC mains powered (with internal battery back-up) FEW4XY.R flow sensor have the following installation conditions:

- No flow straightener or flow conditioner is required.
- For accuracy class 1 and 2, the flow profile sensitivity class is U0/D0.
- For accuracy class 2.5, the installation conditions are specified in Table 1 (see 1.3.1. above).

The Pattern and Variants are approved with the following pressure loss classes based upon flow sensor size and type:

Reduced bore:

- For sizes DN40 and DN50:  $\Delta p_{40}$  (40 kPa)
- For sizes DN65 to DN600:  $\Delta p_{63}$  (63 kPa)

**Table 9 Flow sensor sizes, length and verification scale interval**

Flow sensor size	Meter length (mm)	Verification scale interval (m <sup>3</sup> )
DN40 & DN50	200	0.0001
DN65	200	
DN80	200	
DN100 & DN125	250	0.001
DN150	300	
DN200	350	
DN250	450	
DN300	500	0.01
DN350	550	
DN400	600	
DN450	700	
DN500	770	
DN600	920	

**5. Description of Variant 4**

**approved on 03/10/19  
amended on 25/03/22  
amended on 15/03/24  
amended on 13/05/26**

The Pattern and Variants are approved with the following alternative battery/renewable energy powered flow sensors:

- AquaMaster4 FEW4XY.V (virtual full bore, polypropylene lined) (Figure 9)
- AquaMaster4 FEW4XY.F (full bore, elastomer lined) (Figure 10)

with the sensor sizes, accuracy classes, flowrates and associated characteristics as specified in Tables 10 to 15.

**Table 10 (Virtual) full bore flow sensor – battery/renewable energy powered**

<b>Flow sensor size</b>	<b>Accuracy class</b>	<b>Q1 (m<sup>3</sup>/h)</b>	<b>Q2 (m<sup>3</sup>/h)</b>	<b>Q3 (m<sup>3</sup>/h)</b>	<b>Q4 (m<sup>3</sup>/h)</b>	<b>Ratio Q3/Q1</b>
DN40	1	0.32	0.512	40	50	125
	2	0.16	0.256	40	50	250
	2.5	0.25	-	40	50	160
DN50	1	0.504	0.8064	63	78.75	125
	2	0.252	0.4032	63	78.75	250
	2.5	0.394	-	63	78.75	160
DN65	1 & 2	0.4	0.64	100	125	250
	2.5	0.625	-	100	125	160
DN80	1 & 2	0.64	1.024	160	200	250
	2.5	1.0	-	160	200	160
DN100	1 & 2	1.0	1.6	250	312.5	250
	2.5	1.56	-	250	312.5	160
DN125	1 & 2	1.0	1.6	250	312.5	250
	2.5	1.56	-	250	312.5	160
DN150	1	5.04	8.064	630	787.5	125
	2	2.52	4.032	630	787.5	250
	2.5	3.94	-	630	787.5	160

**Table 11 (Virtual) full bore flow sensor – battery/renewable energy powered**

Flow sensor size	Accuracy class	Q1 (m <sup>3</sup> /h)	Q2 (m <sup>3</sup> /h)	Q3 (m <sup>3</sup> /h)	Q4 (m <sup>3</sup> /h)	Ratio Q3/Q1
DN200	1	8.0	12.8	1000	1250	125
	2	4.0	6.4	1000	1250	250
	2.5	6.25	-	1000	1250	160
DN250	1	12.8	20.48	1600	2000	125
	2	6.4	10.24	1600	2000	250
	2.5	10	-	1600	2000	160
DN300	1	20	32	2500	3125	125
	2	10	16	2500	3125	250
	2.5	15.625	-	2500	3125	160
DN350	1 & 2	16	25.6	4000	5000	250
	2.5	25	-	4000	5000	160
DN400	1 & 2	16	25.6	4000	5000	250
	2.5	25	-	4000	5000	160
DN450	1 & 2	25.2	40.32	6300	7875	250
	2.5	39.375	-	6300	7875	160
DN500	1 & 2	25.2	40.32	6300	7875	250
	2.5	39.375	-	6300	7875	160
DN600	1	78.75	126	6300	7875	250
	2	39.375	63	6300	7875	250
	2.5	63	-	6300	7875	100
DN700	1	200	320	10,000	12,500	50
	2	100	160	10,000	12,500	100
	2.5	158.7	-	10,000	12,500	63

**Table 12 (Virtual) full bore flow sensor – battery/renewable energy powered**

Flow sensor size	Accuracy class	Q1 (m <sup>3</sup> /h)	Q2 (m <sup>3</sup> /h)	Q3 (m <sup>3</sup> /h)	Q4 (m <sup>3</sup> /h)	Ratio Q3/Q1
DN750	1	200	320	10,000	12,500	50
	2	100	160	10,000	12,500	100
	2.5	158.7	-	10,000	12,500	63
DN800	1	200	320	10,000	12,500	50
	2	100	160	10,000	12,500	100
	2.5	158.7	-	10,000	12,500	63
DN900	2	158.7	254	10,000	12,500	63
	2.5	250	-	10,000	12,500	40
DN1000	2	160	250	16,000	20,000	100
	2.5	253.97	-	16,000	20,000	63
DN1050	2	160	250	16,000	20,000	100
	2.5	253.97	-	16,000	20,000	63
DN1100	2	254	406.4	16,000	20,000	63
	2.5	400	-	16,000	20,000	40
DN1200	2	254	406.4	16,000	20,000	63
	2.5	400	-	16,000	20,000	40
DN1350	2	400	640	16,000	20,000	40
	2.5	400	-	16,000	20,000	40
DN1400	2	400	640	16,000	20,000	40
	2.5	400	-	16,000	20,000	40
DN1500	2	400	640	16,000	20,000	40
	2.5	400	-	16,000	20,000	40
DN1600	2	400	640	16,000	20,000	40
	2.5	400	-	16,000	20,000	40
DN1650	2	400	640	16,000	20,000	40
	2.5	400	-	16,000	20,000	40

Alternative flowrate values may be selected under the following conditions:

- Values of  $Q_3$  shall not be greater than those specified in Tables 10, 11 & 12;
- Values of  $Q_1$  shall not be less than those specified in Tables 10, 11 & 12;
- The ratio  $Q_4/Q_3$  shall be 1.25;
- For accuracy class 1 and 2, the ratio of  $Q_2/Q_1$  shall be 1.6;
- For accuracy class 1 and 2, the ratio of  $Q_3/Q_1$  shall be not less than 40 and shall be selected as per clause 4.1.4 of NMI R 49-1; and
- For accuracy class 2.5, the ratio of  $Q_3/Q_1$  shall be selected as per clause 3.1 of NMI M 10-1.

The Pattern and Variants incorporating the FEW4XY.V flow sensor have the following installation conditions:

- No flow straightener or flow conditioner is required.
- For accuracy class 1 and 2, the flow profile sensitivity class is U0/D0.
- For accuracy class 2.5, the installation conditions are specified in Table 13.

**Table 13 Minimum pipe lengths required by flow disturbance type**

Flow Sensor	Disturbance Type (*)	Minimum number of upstream pipe lengths (DN)	Minimum number of downstream pipe lengths (DN)
FEW4XY.V	1	0	0
	2	0	0
	3	0	0

(\*) For information on the different types of flow disturbances which are examined as part of pattern approval, refer to NMI M 10-2.

The Pattern and Variants incorporating the FEW4XY.F flow sensor have the following installation conditions:

- No flow straightener or flow conditioner is required.
- For accuracy class 1 and 2, the flow profile sensitivity class is U3/D0.
- For accuracy class 2.5, the installation conditions are specified in Table 14.

**Table 14 Minimum pipe lengths required by flow disturbance type**

Flow Sensor	Disturbance Type (*)	Minimum number of upstream pipe lengths (DN)	Minimum number of downstream pipe lengths (DN)
FEW4XY.F	1	3	0
	2	3	0
	3	3	0

(\*) For information on the different types of flow disturbances which are examined as part of pattern approval, refer to NMI M 10-2.

The Pattern and Variants incorporating the FEW4XY.V and FEW4XY.F flow sensor have the following power supply options:

When X is either 1 (standard) or 3 (advanced):

- Renewable energy power (DC powered): 6 V – 32 V
- Battery power: 2 x 3.6 V (operating range: 2.9 V – 3.6 V)

When X is 5 (premium - mobile communications):

- Renewable energy power (DC powered): 6 V – 32 V including 4 x 3.6 V replaceable batteries (operating range: 2.9 V – 3.6 V)
- Battery power: 6 x 3.6 V replaceable batteries (operating range: 2.9 V – 3.6 V)

The Pattern and Variants are approved with the following pressure loss classes based upon flow sensor size and type:

(Virtual) full bore:

- For sizes DN40 and DN50:  $\Delta p_{10}$  (10 kPa)
- For sizes DN65 to DN200:  $\Delta p_{16}$  (16 kPa)
- For sizes DN250 to DN1650:  $\Delta p_{10}$  (10 kPa)

**Table 15 Flow sensor sizes, length and verification scale interval**

<b>Flow sensor size</b>	<b>Meter length (mm)</b>	<b>Verification scale interval (m<sup>3</sup>)</b>
DN40 & DN50	200	0.001
DN65	200	
DN80	200	
DN100 & DN125	250	
DN150	300	0.01
DN200	350	
DN250	450	
DN300	500	
DN350	550	
DN400	600	
DN450	600	
DN500	600	
DN600	800	0.1
DN700	700	
DN750	762	
DN800	800	
DN900	900	1
DN1000	1000	
DN1050	1067	
DN1100	1118	
DN1200	1200	
DN1350	1350	
DN1400	1400	
DN1500	1524	
DN1600	1600	
DN1650	1650	

**6. Description of Variant 5**

**approved on 25/03/22**  
**amended on 15/03/24**  
**amended on 13/05/26**

The Pattern and Variants are approved with the following alternative AC mains powered flow sensors:

- AquaMaster4 FEW4XY.V (virtual full bore, polypropylene lined)
- AquaMaster4 FEW4XY.F (full bore, elastomer lined)

with the sensor sizes, accuracy classes, flowrates and associated characteristics as specified in Tables 16 to 22.

AC mains power supply: 85-240 VAC @ 50/60 Hz (with internal battery back-up):

- When X is either 1 (Standard) or 3 (Advanced): 2 x 3.6 V (operating range: 2.9 V – 3.6 V)
- When X is 5 (premium - mobile communications): 4 x replaceable batteries with operating range 2.9 V to 3.6 V)

**Table 16 (Virtual) full bore flow sensor – AC mains powered**

<b>Flow sensor size</b>	<b>Accuracy class</b>	<b>Q1 (m<sup>3</sup>/h)</b>	<b>Q2 (m<sup>3</sup>/h)</b>	<b>Q3 (m<sup>3</sup>/h)</b>	<b>Q4 (m<sup>3</sup>/h)</b>	<b>Ratio Q3/Q1</b>
DN40	1 & 2	0.08	0.128	40	50	500
	2.5	0.127	-	40	50	315
DN50	1 & 2	0.126	0.2016	63	78.75	500
	2.5	0.2	-	63	78.75	315
DN65	1 & 2	0.2	0.32	100	125	500
	2.5	0.32	-	100	125	315
DN80	1 & 2	0.32	0.512	160	200	500
	2.5	0.508	-	160	200	315
DN100	1 & 2	0.5	0.8	250	312.5	500
	2.5	0.79	-	250	312.5	315
DN125	1 & 2	0.5	0.8	250	312.5	500
	2.5	0.79	-	250	312.5	315
DN150	1	2.52	4.032	630	787.5	250
	2	1.26	2.016	630	787.5	500
	2.5	2.0	-	630	787.5	315
DN200	1	4.0	6.4	1000	1250	250
	2	2.0	3.2	1000	1250	500
	2.5	3.17	-	1000	1250	315

**Table 17 (Virtual) full bore flow sensor – AC mains powered**

<b>Flow sensor size</b>	<b>Accuracy class</b>	<b>Q1 (m<sup>3</sup>/h)</b>	<b>Q2 (m<sup>3</sup>/h)</b>	<b>Q3 (m<sup>3</sup>/h)</b>	<b>Q4 (m<sup>3</sup>/h)</b>	<b>Ratio Q3/Q1</b>
DN250	1	6.4	10.24	1600	2000	250
	2	3.2	5.12	1600	2000	500
	2.5	5.08	-	1600	2000	315
DN300	1	10	16	2500	3125	250
	2	5.0	8.0	2500	3125	500
	2.5	7.94	-	2500	3125	315
DN350	1 & 2	40	64	4000	5000	100
	2.5	63.49	-	4000	5000	63
DN400	1 & 2	40	64	4000	5000	100
	2.5	63.49	-	4000	5000	63
DN450	1 & 2	63	100.8	6300	7875	100
	2.5	100	-	6300	7875	63
DN500	1 & 2	63	100.8	6300	7875	100
	2.5	100	-	6300	7875	63
DN600	1 & 2	63	100.8	6300	7875	100
	2.5	100	-	6300	7875	63
DN700	1	100	160	10,000	12,500	100
	2	50	80	10,000	12,500	200
	2.5	80	-	10,000	12,500	125
DN750	1	100	160	10,000	12,500	100
	2	50	80	10,000	12,500	200
	2.5	80	-	10,000	12,500	125

**Table 18 (Virtual) full bore flow sensor – AC mains powered**

Flow sensor size	Accuracy class	Q1 (m <sup>3</sup> /h)	Q2 (m <sup>3</sup> /h)	Q3 (m <sup>3</sup> /h)	Q4 (m <sup>3</sup> /h)	Ratio Q3/Q1
DN800	1	100	160	10,000	12,500	100
	2	50	80	10,000	12,500	200
	2.5	80	-	10,000	12,500	125
DN900	1	158.7	253.9	10,000	12,500	63
	2	80	128	10,000	12,500	125
	2.5	125	-	10,000	12,500	80
DN1000	1	160	256	16,000	20,000	100
	2	80	128	16,000	20,000	200
	2.5	128	-	16,000	20,000	125
DN1050	1	160	256	16,000	20,000	100
	2	80	128	16,000	20,000	200
	2.5	128	-	16,000	20,000	125
DN1100	1	253.9	406.2	16,000	20,000	63
	2	128	204.8	16,000	20,000	125
	2.5	200	-	16,000	20,000	80
DN1200	1	253.9	406.2	16,000	20,000	63
	2	128	204.8	16,000	20,000	125
	2.5	200	-	16,000	20,000	80
DN1350	1	400	640	16,000	20,000	40
	2	200	320	16,000	20,000	80
	2.5	254	-	16,000	20,000	63
DN1400	1	400	640	16,000	20,000	40
	2	200	320	16,000	20,000	80
	2.5	254	-	16,000	20,000	63
DN1500	1	400	640	16,000	20,000	40
	2	200	320	16,000	20,000	80
	2.5	254	-	16,000	20,000	63

**Table 19 (Virtual) full bore flow sensor – AC mains powered**

DN1600	1	400	640	16,000	20,000	40
	2	200	320	16,000	20,000	80
	2.5	400	-	16,000	20,000	40
DN1650	1	400	640	16,000	20,000	40
	2	200	320	16,000	20,000	80
	2.5	400	-	16,000	20,000	40
DN1800	1	320	512	16,000	20,000	50
	2	320	512	16,000	20,000	50
	2.5	400	-	16,000	20,000	40

Alternative flowrate values may be selected under the following conditions:

- Values of  $Q_3$  shall not be greater than those specified in Tables 16, 17, 19 & 19;
- Values of  $Q_1$  shall not be less than those specified in Tables 16, 17, 18 & 19;
- The ratio  $Q_4/Q_3$  shall be 1.25;
- For accuracy class 1 and 2, the ratio of  $Q_2/Q_1$  shall be 1.6;
- For accuracy class 1 and 2, the ratio of  $Q_3/Q_1$  shall be not less than 40 and shall be selected as per clause 4.1.4 of NMI R 49-1; and
- For accuracy class 2.5, the ratio of  $Q_3/Q_1$  shall be selected as per clause 3.1 of NMI M 10-1.

The Pattern and Variants incorporating the FEW4XY.V flow sensor have the following installation conditions:

- No flow straightener or flow conditioner is required.
- For accuracy class 1 and 2, the flow profile sensitivity class is U0/D0.
- For accuracy class 2.5, the installation conditions are specified in Table 20.

**Table 20 Minimum pipe lengths required by flow disturbance type**

Flow Sensor	Disturbance Type (*)	Minimum number of upstream pipe lengths (DN)	Minimum number of downstream pipe lengths (DN)
FEW4XY.V	1	0	0
	2	0	0
	3	0	0

(\*) For information on the different types of flow disturbances which are examined as part of pattern approval, refer to NMI M 10-2.

The Pattern and Variants incorporating the FEW4XY.F flow sensor have the following installation conditions:

- No flow straightener or flow conditioner is required.
- For accuracy class 1 and 2, the flow profile sensitivity class is U3/D0.
- For accuracy class 2.5, the installation conditions are specified in Table 21.

**Table 21 Minimum pipe lengths required by flow disturbance type**

Flow Sensor	Disturbance Type (*)	Minimum number of upstream pipe lengths (DN)	Minimum number of downstream pipe lengths (DN)
FEW4XY.F	1	3	0
	2	3	0
	3	3	0

(\*) For information on the different types of flow disturbances which are examined as part of pattern approval, refer to NMI M 10-2.

The Pattern and Variants are approved with the following pressure loss classes based upon flow sensor size and type:

(Virtual) full bore:

- For sizes DN40 and DN50:  $\Delta p_{10}$  (10 kPa)
- For sizes DN65 to DN200:  $\Delta p_{16}$  (16 kPa)
- For sizes DN250 to DN1800:  $\Delta p_{10}$  (10 kPa)

**Table 22 Flow sensor sizes, length and verification scale interval**

<b>Flow sensor size</b>	<b>Meter length (mm)</b>	<b>Verification scale interval (m<sup>3</sup>)</b>
DN40 & DN50	200	0.0001
DN65	200	
DN80	200	0.001
DN100 & DN125	250	
DN150	300	
DN200	350	0.01
DN250	450	
DN300	500	
DN350	550	
DN400	600	0.1
DN450	700	
DN500	770	
DN600	920	
DN700	700	
DN750	762	
DN800	800	
DN900	900	
DN1000	1000	
DN1050	1067	
DN1100	1118	
DN1200	1200	
DN1350	1350	1
DN1400	1400	
DN1500	1524	
DN1600	1600	
DN1650	1650	
DN1800	1800	

**7. Description of Variant 6**

**approved on 25/03/22**

The Pattern and Variants are approved with the AquaMaster4 signal transmitter and the alternative AquaMaster3 FEV 2 electromagnetic full bore flow sensor (Figure 11 and 12) with the sensor sizes, flowrates and associated characteristics as specified in Tables 23 to 25.

**Table 23 AquaMaster3 FEV 2 full bore flow sensor**

<b>Flow sensor size</b>	<b>Accuracy class</b>	<b>Q1 (m<sup>3</sup>/h)</b>	<b>Q2* (m<sup>3</sup>/h)</b>	<b>Q3 (m<sup>3</sup>/h)</b>	<b>Q4 (m<sup>3</sup>/h)</b>	<b>Ratio Q3/Q1</b>
DN40	2 & 2.5	0.25	0.40	40	50	160
DN50	2 & 2.5	0.39375	0.63	63	78.75	160
DN65	2 & 2.5	0.625	1.0	100	125	160
DN80	2 & 2.5	1.0	1.6	160	200	160
DN100	2 & 2.5	1.5625	2.5	250	312.5	160
DN125	2 & 2.5	1.5625	2.5	250	312.5	160
DN150	2 & 2.5	3.9375	6.3	630	787.5	160
DN200	2 & 2.5	6.25	10	1000	1250	160

\* For class 2 meters only.

Alternative flowrate values may be selected under the following conditions:

- Values of Q<sub>3</sub> shall not be greater than those specified in Table 23;
- Values of Q<sub>1</sub> shall not be less than those specified in Table 23;
- The ratio Q<sub>4</sub>/Q<sub>3</sub> shall be 1.25;
- For accuracy class 2, the ratio of Q<sub>2</sub>/Q<sub>1</sub> shall be 1.6;
- For accuracy class 2, the ratio of Q<sub>3</sub>/Q<sub>1</sub> shall be not less than 40 and shall be selected as per clause 4.1.4 of NMI R 49-1; and
- For accuracy class 2.5, the ratio of Q<sub>3</sub>/Q<sub>1</sub> shall be selected as per clause 3.1 of NMI M 10-1.

The Pattern and Variants incorporating the AquaMaster3 FEV 2 full bore flow sensor have the following power supply options:

- Renewable energy power (DC powered): 6 – 32 V
- Battery power: 2 x 3.6 V (operating range: 2.9 V – 3.6 V)
- AC mains power supply: 85-240 VAC @ 50/60 Hz (with internal battery back-up)

The Pattern and Variants incorporating the AquaMaster3 FEV 2 full bore flow sensor have the following installation conditions:

- No flow straightener or flow conditioner is required.
- For accuracy class 2, the flow profile sensitivity class is U0/D0.
- For accuracy class 2.5, the installation conditions are specified in Table 24.

**Table 24 Minimum pipe lengths required by flow disturbance type**

Flow Sensor	Disturbance Type (*)	Minimum number of upstream pipe lengths (DN)	Minimum number of downstream pipe lengths (DN)
FEV 2	1	0	0
	2	0	0
	3	0	0

(\*) For information on the different types of flow disturbances which are examined as part of pattern approval, refer to NMI M 10-2.

The Pattern and Variants are approved with the following pressure loss classes based upon flow sensor size and type:

(Virtual) full bore:

- For sizes DN40 and DN50:  $\Delta p_{10}$  (10 kPa)
- For sizes DN65 to DN200:  $\Delta p_{16}$  (16 kPa)

**Table 25 Flow sensor sizes, length and verification scale interval**

Flow sensor size	Meter length (mm)	Verification scale interval (m <sup>3</sup> )
DN40 & DN50	200	0.001
DN65	200	0.001
DN80	200	0.001
DN100 & DN125	250	0.001
DN150	300	0.01
DN200	350	0.01

**8. Description of Variant 7**

**approved on 25/03/22**

The Pattern and Variants are approved with the alternative WaterMaster signal transmitter and WaterMaster FEV, WaterMaster FEW or WaterMaster FEF (virtual full bore, polypropylene lined or full bore, elastomer lined) electromagnetic flow sensor (Figure 13 and 14) with the sensor sizes, flowrates and associated characteristics specified in Tables 26 to 29.

**Table 26 WaterMaster virtual/ full bore flow sensor**

<b>Flow sensor size</b>	<b>Accuracy class</b>	<b>Q1 (m<sup>3</sup>/h)</b>	<b>Q2 (m<sup>3</sup>/h)</b>	<b>Q3 (m<sup>3</sup>/h)</b>	<b>Q4 (m<sup>3</sup>/h)</b>	<b>Ratio Q3/Q1</b>
DN40	2	0.25	0.40	40	50	160
	2.5	0.40	-	40	50	100
DN50	2	0.39375	0.63	63	100	160
	2.5	0.63	-	63	100	100
DN65	2	0.625	1.0	100	125	160
	2.5	1.0	-	100	125	100
DN80	2	1.0	1.6	160	200	160
	2.5	1.6	-	160	200	100
DN100	2	1.5625	2.5	250	312.5	160
	2.5	2.5	-	250	312.5	100
DN125	2	1.5625	2.5	250	312.5	160
	2.5	2.5	-	250	312.5	100
DN150	2	3.9375	6.3	630	787.5	160
	2.5	6.3	-	630	787.5	100
DN200	2	6.25	10	1000	1250	160
	2.5	10	-	1000	1250	100
DN250	2	10	16	1600	2000	160
	2.5	16	-	1600	2000	100
DN300	2	15.625	25	2500	3125	160
	2.5	25	-	2500	3125	100

**Table 27 WaterMaster virtual/ full bore flow sensor**

Flow sensor size	Accuracy class	Q1 (m <sup>3</sup> /h)	Q2 (m <sup>3</sup> /h)	Q3 (m <sup>3</sup> /h)	Q4 (m <sup>3</sup> /h)	Ratio Q3/Q1
DN350	2	25	40	4000	5000	160
	2.5	40	-	4000	5000	100
DN400	2	25	40	4000	5000	160
	2.5	40	-	4000	5000	100
DN450	2	40	64	4000	5000	100
	2.5	63.49	-	4000	5000	63
DN500	2	40	64	4000	5000	100
	2.5	63.49	-	4000	5000	63

Alternative flowrate values may be selected under the following conditions:

- Values of Q<sub>3</sub> shall not be greater than those specified in Table 26 and 27;
- Values of Q<sub>1</sub> shall not be less than those specified in Table 26 and 27;
- The ratio Q<sub>4</sub>/Q<sub>3</sub> shall be 1.25;
- For accuracy class 2, the ratio of Q<sub>2</sub>/Q<sub>1</sub> shall be 1.6;
- For accuracy class 2, the ratio of Q<sub>3</sub>/Q<sub>1</sub> shall be not less than 40 and shall be selected as per clause 4.1.4 of NMI R 49-1; and
- For accuracy class 2.5, the ratio of Q<sub>3</sub>/Q<sub>1</sub> shall be selected as per clause 3.1 of NMI M 10-1.

The Pattern and Variants incorporating the WaterMaster FEV, WaterMaster FEW or WaterMaster FEF flow sensor have the following power supply options:

- DC powered: 24 V DC (+/-30% (18.46V to 31.2V DC) @ <0.4A)
- LOW VOLTAGE 24 V AC +10 % / -30% @ <7 VA
- Mains 85 to 265 V AC @ < 7 VA

The Pattern and Variants incorporating the WaterMaster FEV, WaterMaster FEW or WaterMaster FEF flow sensor have the following installation conditions:

- No flow straightener or flow conditioner is required.
- For accuracy class 2, the flow profile sensitivity class is U0/D0.
- For accuracy class 2.5, the installation conditions are specified in Table 28.

**Table 28 Minimum pipe lengths required by flow disturbance type**

Flow Sensor	Disturbance Type (*)	Minimum number of upstream pipe lengths (DN)	Minimum number of downstream pipe lengths (DN)
FEV, FEW, FEF	1	0	0
	2	0	0
	3	0	0

(\*) For information on the different types of flow disturbances which are examined as part of pattern approval, refer to NMI M 10-2.

The Pattern and Variants are approved with the following pressure loss classes based upon flow sensor size and type:

(Virtual) full bore:

- For sizes DN40 and DN50:  $\Delta p_{10}$  (10 kPa)
- For sizes DN65 to DN200:  $\Delta p_{16}$  (16 kPa)
- For sizes DN250 to DN500:  $\Delta p_{10}$  (10 kPa)

**Table 29 Flow sensor sizes, length and verification scale interval**

Flow sensor size	Meter length (mm)	Verification scale interval (m <sup>3</sup> )
DN40 & DN50	200	0.001
DN65	200	0.001
DN80	200	0.001
DN100 & DN125	250	0.001
DN150	300	0.01
DN200	350	
DN250	450	
DN300	500	
DN350	550	
DN400	600	
DN450	700	
DN500	770	

## TEST PROCEDURE No 14/3/46

This Approval and Certificate is issued only with respect to the design (the pattern and variants) of the water meter described herein. The calibration and measurement accuracy of individual water meters manufactured and marked in accordance with the approved pattern and variants should be verified in accordance with the test procedures specified below, or as required by relevant legislation.

Water meters tested for verification shall comply with the Certificate of Approval, Technical Schedule, and the maximum permissible errors for verification at the operating conditions in effect at the time of verification. Maximum permissible errors for verification of water meters are given in the *National Trade Measurement Regulations 2009* (Cth).

Water meters shall be verified in accordance with the following national instrument test procedures:

- NITP 14.0 – Utility meters – general requirements
- NITP 14.3 – Utility meters – water meters

For accuracy class 2.5 meters:

- The maximum permissible errors for initial verification shall be  $\pm 2.5\%$  from  $Q_1$  to  $Q_4$ .

NOTE: NMI reserves the right to vary this procedure. Any such variation shall be notified in writing by NMI.

FIGURE 14/3/46 – 1



ABB AquaMaster4 Model Water Meter – The Pattern

FIGURE 14/3/46 – 2



AquaMaster4 signal transmitter (indicating device) – The Pattern

FIGURE 14/3/46 – 3



AquaMaster4 – Sealing Device: read-only switch

FIGURE 14/3/46 – 4

Tamper-detection seal /  
locking screw locations

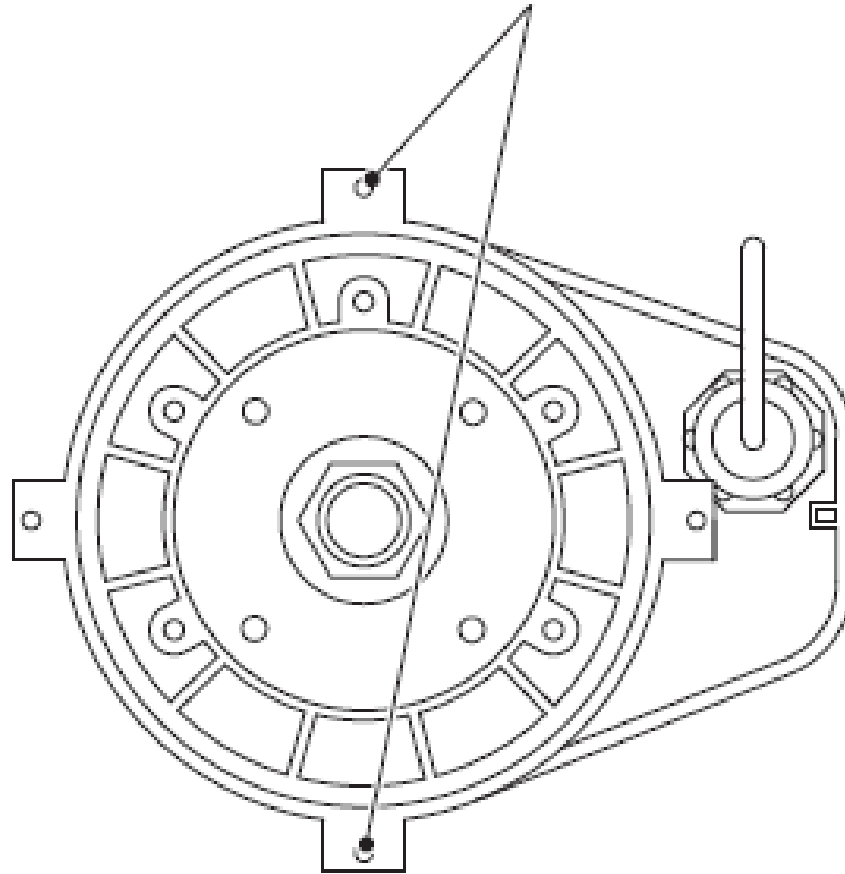

AquaMaster4 – Sealing Device: physical seals

FIGURE 14/3/46 – 5



AquaMaster4 – Example of Required Markings

FIGURE 14/3/46 – 6



AquaMaster4 – Compact and Remote Arrangements

FIGURE 14/3/46 – 7

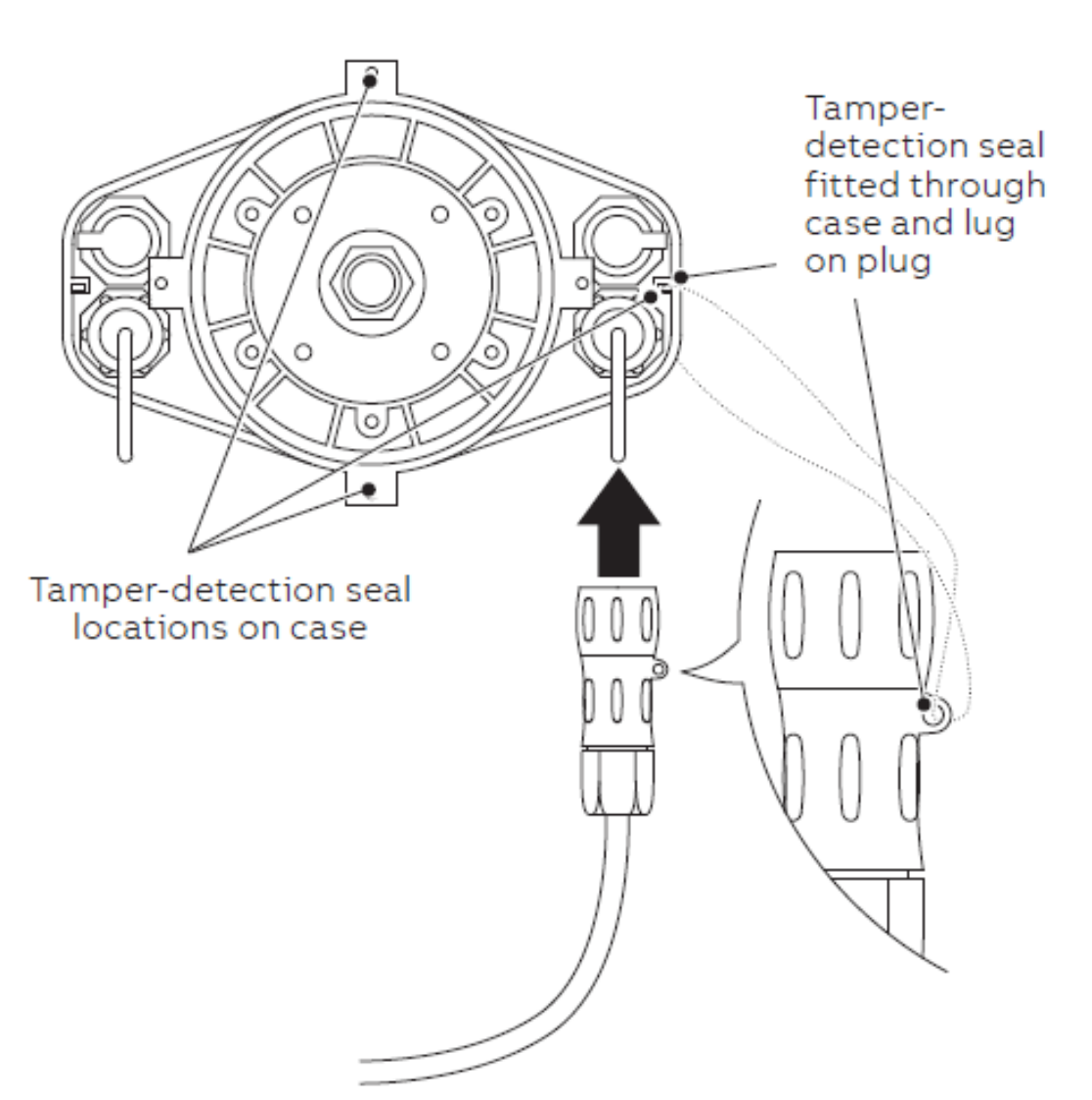

AquaMaster4 – Remote Arrangement Sealing

FIGURE 14/3/46 – 8

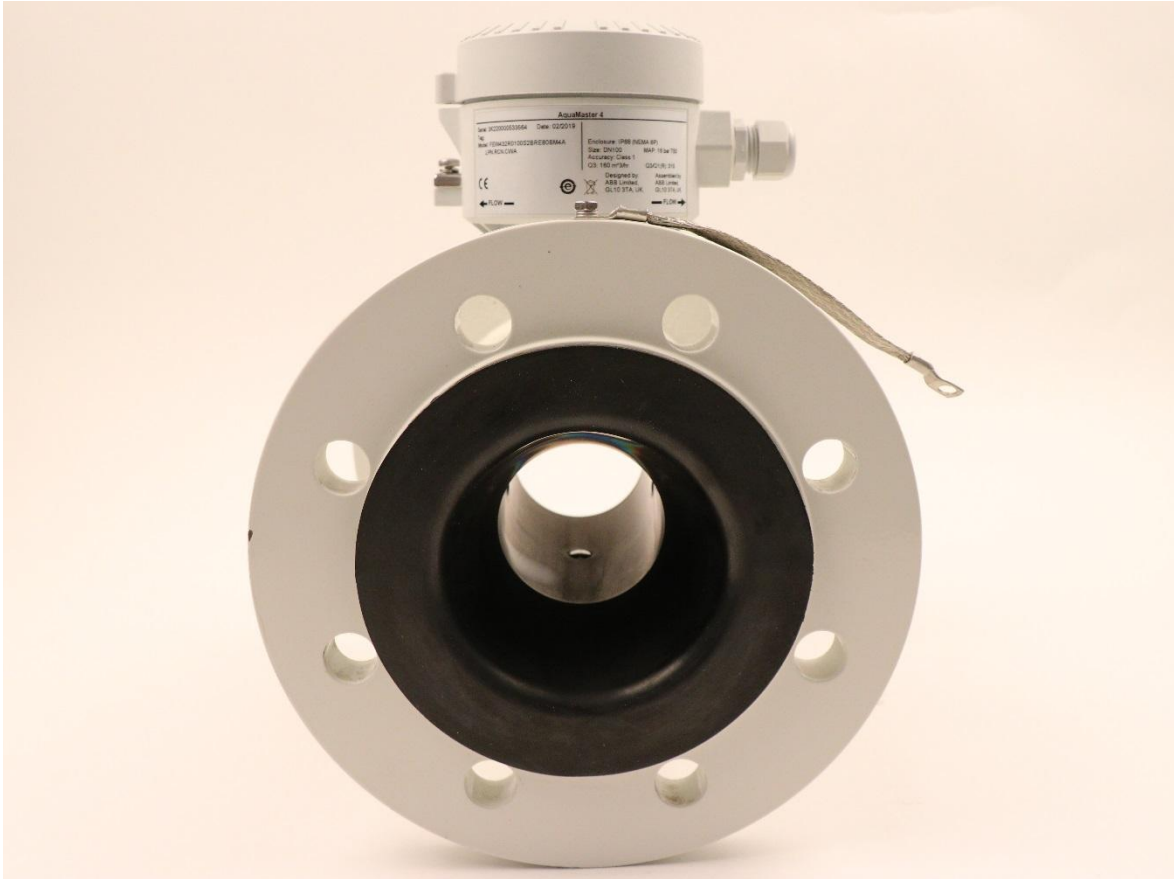

AquaMaster4 – FEW4XX.R sensor (Variant 1 to 3)

FIGURE 14/3/46 – 9



AquaMaster4 – FEW4XX.V sensor (Variant 4 & 5)

FIGURE 14/3/46 – 10



AquaMaster4 – FEW4XX.F sensor (Variant 4 & 5)

FIGURE 14/3/46 – 11



AquaMaster FEV 2 electromagnetic full bore flow sensor – Variant 6

FIGURE 14/3/46 – 12

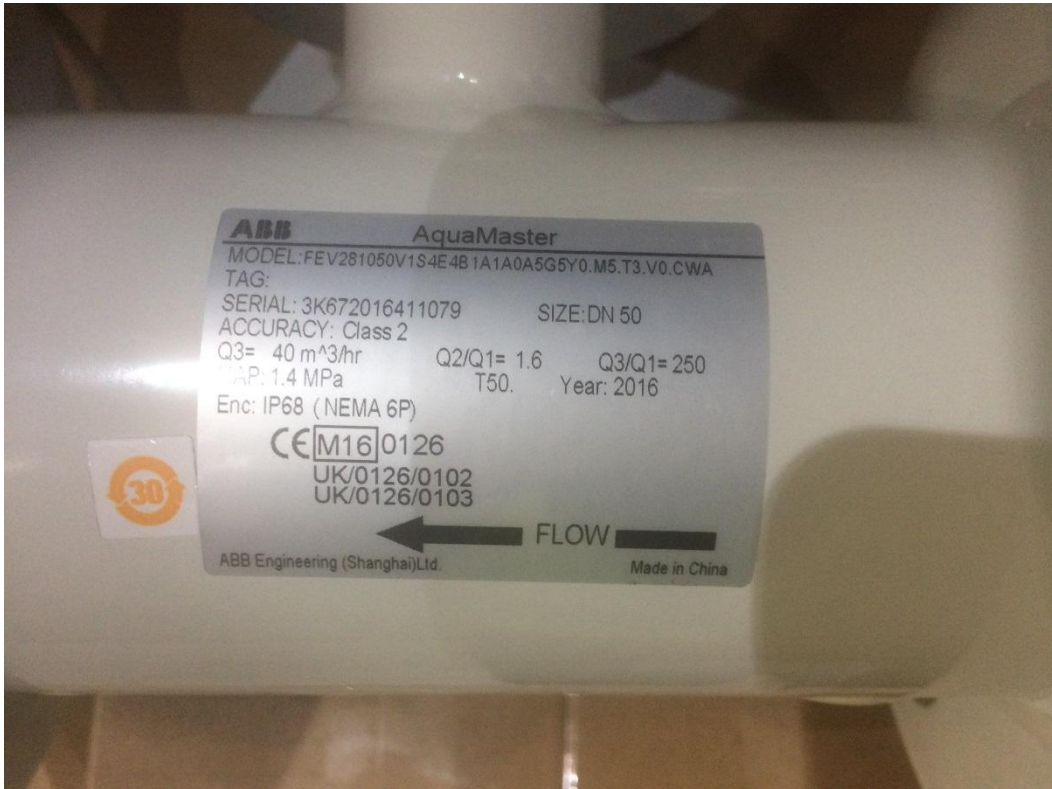

AquaMaster FEV 2 flow sensor (example markings) – Variant 6

FIGURE 14/3/46 – 13



WaterMaster compact and remote versions – Variant 7

FIGURE 14/3/46 – 14



WaterMaster (example markings) – Variant 7

~ End of Document ~