



Australian Government  
Department of Industry,  
Science and Resources

**National  
Measurement  
Institute**

36 Bradfield Road, West Lindfield NSW 2070

## **Certificate of Approval**

### **NMI 6/9C/327**

Issued by the Chief Metrologist under Regulation 60  
of the  
*National Measurement Regulations 1999*

This is to certify that an approval for use for trade has been granted in respect of the instruments herein described.

Mettler Toledo TLF820 Forklift Weighing Instrument

submitted by Mettler-Toledo Limited  
220 Turner Street  
Port Melbourne Victoria 3207

**NOTE:** This Certificate relates to the suitability of the pattern of the instrument for use for trade only in respect of its metrological characteristics. This Certificate does not constitute or imply any guarantee of compliance by the manufacturer or any other person with any requirements regarding safety.

This approval has been granted with reference to document NMI R 76, *Non-automatic weighing instruments, Parts 1 and 2*, dated October 2015.

This approval is subject to review at the decision of the Chief Metrologist in accordance with the conditions specified in the document NMI P 106.

#### DOCUMENT HISTORY

<b>Rev</b>	<b>Reason/Details</b>	<b>Date</b>
0	Pattern & variant 1 approved – certificate issued	26/04/23
1	Variant 2 provisionally approved – certificate issued	26/06/23
2	Variant 3 approved – certificate issued	07/12/23

## CONDITIONS OF APPROVAL

### General

Instruments purporting to comply with this approval shall be marked with pattern approval number 'NMI 6/9C/327' and only by persons authorised by the submittor.

It is the submittor's responsibility to ensure that all instruments marked with this approval number are constructed as described in the documentation lodged with the National Measurement Institute (NMI) and with the relevant Certificate of Approval and Technical Schedule. Failure to comply with this Condition may attract penalties under Section 19B of the National Measurement Act and may result in cancellation or withdrawal of the approval, in accordance with document NMI P 106.

Auxiliary devices used with this instrument shall comply with the requirements of General Supplementary Certificate No S1/0B.

### Special

This approval shall NOT be used in conjunction with General Certificate No 6B/0.

### Special Conditions of Approval: (Provisional Approval – Variant 2)

This variant is provisional pending the completion of satisfactory in-situ testing of a sample instrument and the evaluation of results.

Instruments purporting to comply with this variant shall be marked with approval number 'NMI P6/9C/327' and only by persons authorised by the submittor (Note: The 'P' in the approval number may be a temporary marking).

Four TLF820 Forklift Weighing Instruments with 1820 mm tines can be installed at FedEx Express / TNT Australasia, 14-32 Transport Ave, Netley, SA 5037.

In the event of unsatisfactory performance, the approval of this variant may be cancelled (or varied). The submittor shall implement such modifications as required by NMI. In the event that such modifications (if any are required by NMI) are not made to the satisfaction of NMI, the approval of this variant may be withdrawn.

Signed by a person authorised by the Chief Metrologist to exercise their powers under Regulation 60 of the *National Measurement Regulations 1999*.



**Darryl Hines**  
Manager  
Policy and Regulatory services

## TECHNICAL SCHEDULE No 6/9C/327

### 1. Description of Pattern approved on 26/04/23

A Mettler Toledo model TLF820-2-II-1040E Forklift Scale class  single interval self-indicating non-automatic weighing instrument of 2000 kg maximum capacity with a verification scale interval of 2 kg and with a minimum capacity of 40 kg fitted to a forklift truck (Figure 1 and Table 1).

The instrument is intended to operate only whilst the forklift and its carriage are stationary (i.e. not whilst the forklift is in motion, or whilst the load is being moved). It is however acceptable for the forklift or load to be moved between the zeroing of the instrument and the weighing of the load.

Instruments may be fitted with output sockets (output interfacing capability) for the connection of auxiliary and/or peripheral devices.

#### 1.1 Load Receptor/Carriage

The load receptor consists of a Mettler Toledo model VFS 120 weighing module (Figures 2a and 2b) fitted to a forklift truck, and on which two lifting forks (tines) are mounted as shown in Figure 1. The fork length of TLF820-2II-1040E forklift scale is 1220 mm.

The VFS 120 weighing module has two tension type load cells and a linkage mechanism. The weighing module is intended to be located on the forklift carriage.

#### 1.2 Load Cells

Two Mettler Toledo model TSH-2 stainless steel load cells of 2000 kg maximum capacity are used.

#### 1.3 Levelling

A tilt sensor (2-axis inclinometer) model ZCT210M-NTR is fitted within the IND236-TLF indicator, such that it will reflect tilting of the load receptor and will detect the degree to which the instrument is tilted from its reference (level) condition.

This tilt sensor provides a signal to the indicator. The indicator imposes limits on the level condition, automatically compensates for out of level conditions in longitudinal or transverse directions and disables the weight determination if acceptable levels of tilt are exceeded (nominally  $\pm 5^\circ$  tilt from horizontal).

##### (i) Stability of Ground

The site chosen for weighing should be firm and within the limits of the tilt sensor. The stability of the ground surface should also be considered as subsidence or compaction may affect accuracy.

#### 1.4 Indicator

The instrument has an IND236-TLF indicator which consists of an IND236 indicator, a tilt sensor, and a junction board.

The IND236-TLF indicator is fitted sideways on the VFS 120 weighing module and is connected to the VFS 120 weighing module and a Mettler Toledo ACM360 Bluetooth device (Figure 6). The weighing result is transmitted to a Mettler Toledo SmartPC terminal model OctoCSM by using Bluetooth protocol.

The SmartPC terminal OctoCSM provides the primary display and is mounted near

the forklift operator (Figure 3).

#### 1.4.1 Zero

The initial zero-setting device has a nominal range of not more than 20% of the maximum capacity of the instrument.

The instrument has a semi-automatic zero-setting device with a nominal range of not more than 4% of the maximum capacity of the instrument.

The zero-tracking device shall be disabled.

#### 1.4.2 Display Check

A display check is initiated whenever power is applied.

#### 1.4.3 Additional Features

Instruments also have certain additional functions (e.g. counting, animal weighing, over/under functions). These functions and displays are not approved for trade use.

#### 1.4.4 Power Supply

The instrument may be powered by 12 - 36 V DC from the forklift truck battery.

#### 1.4.5 Interfaces

Instruments may be fitted with interfaces for the connection of auxiliary and/or peripheral devices. Any interfaces shall comply with clause 5.3.6 of document NMI R76 (the basic intent of which is that it shall not be possible to alter weighing results via the interfaces).

Any measurement data output from the instrument or its interfaces shall only be used for trade in compliance with General Supplementary Certificate of Approval No S1/0B (in particular regarding the data and its format).

Instruments may be fitted with RS232, USB, and Bluetooth interfaces.

### 1.5 Descriptive Markings and Notices

Instruments are marked with the following data:

Manufacturer's mark, or name written in full	Mettler Toledo
Indication of accuracy class	
Pattern approval number for the instrument	NMI 6/9C/327
Maximum capacity	Max ..... kg #
Minimum capacity	Min ..... kg #
Verification scale interval	e =..... kg #
Serial number of the instrument	.....

# These markings are shown near the display of the result.

Instruments shall carry a notice clearly visible to the operator stating NOT TO USE THE INSTRUMENT UNLESS THE SITE FOR WEIGHING IS FIRM AND THE INSTRUMENT IS WITHIN TILT LIMIT, or similar wording.

### 1.6 Verification Provision

Provision is made for the application of a verification mark.

## 1.7 Sealing Provision

Provision is made for access to the calibration switch within the IND236-TLF indicator to be sealed by use of a 'lead and wire' or similar type seal with a drilled bolt to prevent access within the instrument housing as shown in Figure 4a.

The Bluetooth device is sealed by use of a 'lead and wire' or similar type seal with a drilled bolt as shown in Figure 4b.

## 1.8 Software

Software versions and checksums are as follows.

Display model	Software version	Checksum
IND236-TLF Indicator	1.xx.xxxx (x = 0 to 9)	No checksum
SmartPC Terminal OctoCSM	1.1.x.x	0x8d6aeabc
Data Storage Device / OctoAMS	1.1.x.x	0x2de38b57

The software identifications of IND236-TLF indicator and of the OctoCSM software can be displayed by the OctoCSM software on the SmartPC terminal after pressing the 'ABOUT' button (Figure 5).

## 2. Description of Variant 1

approved on 26/04/23

The Mettler Toledo TLF820 forklift scale as described for the pattern but of different models of differing capacities which use weighing modules as indicated in Table 1 below. (The model of weighing module described for the pattern and the specifications of pattern are shown in **bold**.)

The TLF820 forklift scale with a maximum capacity of 2000 kg or 3000 kg, and with carriage widths from 920 mm to 1150 mm, and having a fork length of 1220 mm.

The TLF820 forklift scale with a maximum capacity of 5000 kg, and with a carriage width of 1250 mm, and having a fork length of 1520 mm.

TABLE 1

Type	TLF820-2-II-XXXXE#	TLF820-3-II-XXXXE#	TLF820-5-II-XXXXE#
Accuracy class			
Maximum capacity (Max)	<b>2000 kg</b>	3000 kg	5000 kg
Minimum capacity (Min)	<b>40 kg</b>	40 kg	100 kg
Verification scale interval (e)	<b>2 kg</b>	2 kg	5 kg
Carriage height (mm)	<b>411</b>	510	639
Load cell model	<b>TSH-2</b>	TSH-3	TSH-5

#: XXXX represents carriage width from 920 mm to 1250 mm.

Note: Forklift carriage sizes are also allocated 'classes'. Care shall be taken to distinguish these classes from the non-automatic weighing instrument class (which is represented within an oval).

**3. Description of Variant 2** **provisionally approved on 26/06/23**

The Mettler Toledo TLF820-2-II-XXXXE (where XXXX represents carriage width from 920 mm to 1250 mm) forklift scales may be fitted with 1820 mm forks (tines).

**4. Description of Variant 3** **approved on 07/12/23**

The Mettler Toledo TLF820 forklift scale fitted with 1520 mm forks (tines) is similar to the pattern, but as a class III single interval self-indicating non-automatic weighing instrument and so marked, and with the specifications listed in TABLE 2.

TABLE 2

Type	TLF820-2-II-XXXXE#	TLF820-3-II-XXXXE#
Accuracy class	III	
Maximum capacity ( <i>Max</i> )	2000 kg	3000 kg
Minimum capacity ( <i>Min</i> )	40 kg	40 kg
Verification scale interval ( <i>e</i> )	2 kg	2 kg
Carriage height (mm)	411	510
Load cell model	TSH-2	TSH-3
Fork/Tine length (mm)	1520	1520

#: XXXX represents carriage width from 920 mm to 1250 mm.

## TEST PROCEDURE No 6/9C/327

Instruments shall be tested in accordance with any relevant tests specified in the National Instrument Test Procedures (NITP), taking into account the following notes.

The instrument shall not be adjusted to anything other than as close as practical to zero error, even when these values are within the maximum permissible errors.

### Maximum Permissible Errors

The maximum permissible errors are specified in Schedule 1 of the *National Trade Measurement Regulations 2009*.

### Notes:

#### Levelling Arrangements and Stability of Ground

The site chosen for weighing should be firm and within 1.5 degrees of level – the level sensing device imposes limits on the level condition, however the stability of the ground surface should also be considered as well as safety concerns.

#### Gravity Variation

Where the instrument is verified in one location and subsequently moved to another location, the effects of differences in the acceleration of gravity at each location may need to be considered.

Testing shall be carried out with the forks with which the instrument is to be used in normal operation, and with the load applied in a manner similar to normal operation (e.g., for an instrument used for weighing pallets, fit the weighing instrument to a forklift truck, place an empty standard size (1200 × 1200 mm, nominal) hardwood/plastic pallet on the forks and raise above the ground.

Testing shall be carried out with the instrument having zero set using an initial zero-setting or semi-auto zero-setting device with a pallet on the forks and having the forks tilted to their reference (level) condition.

#### Tests (in addition to those in the NITP)

##### 1) Eccentricity

Using a known load of approximately  $1/3$  *Max*, carry out tests to determine whether operation is within the maximum permissible errors with this load at the left, right, front and rear of the pallet.

##### 2) Tilting

Carry out tests to determine whether operation is within the maximum permissible errors, with loads of  $1/2$  *Max* and close to *Max* by having the forks tilted to their reference (level) condition and then having the forks tilted forward until the instrument is disabled (weighing display showing 'Err 5') and gradually reducing the degree of tilt until a weight value is reacquired.

Repeat the test with the forks tilted backward.

Repeat the test with the forklift truck tilted sideways (left and right). Note: Health and safety concerns may impose a safe tilt limit. **DO NOT EXCEED SAFE CONDITIONS.** Only perform the tilt test to its allowed safe limit.

FIGURE 6/9C/327 - 1



Mettler Toledo Model TFL820 (Pattern) with IND236-TFL Mounting Position

FIGURE 6/9C/327 – 2



(a) Mettler Toledo Model VFS120 Weighing Module – Front View

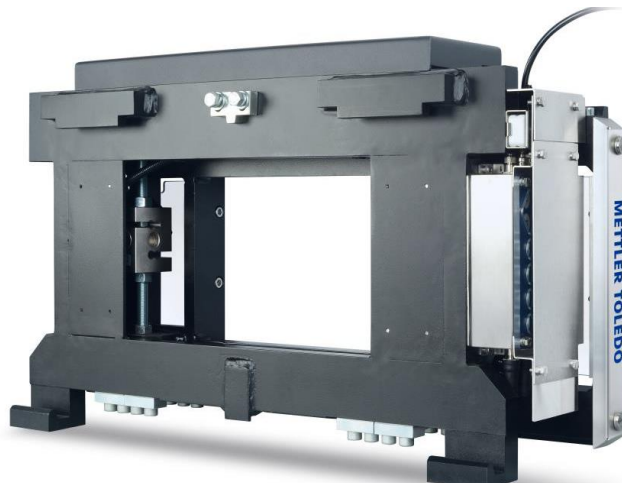

(b) Mettler Toledo Model VFS120 Weighing Module – Rear View

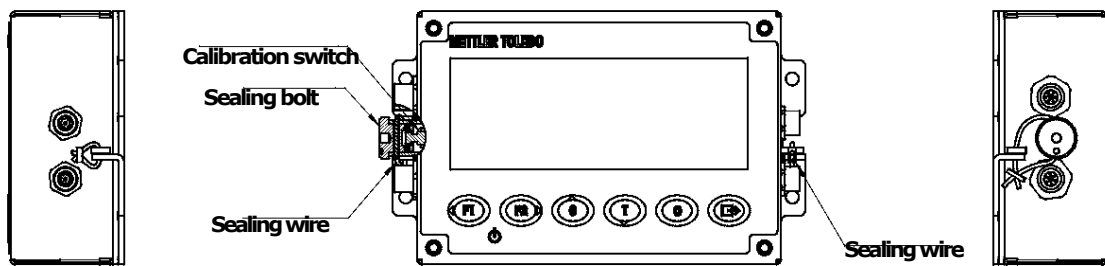

FIGURE 6/9C/327 – 3



Typical Mounting of SmartPC on Forklift

FIGURE 6/9C/327 – 4



(a) Typical IND236-TLF Sealing Method

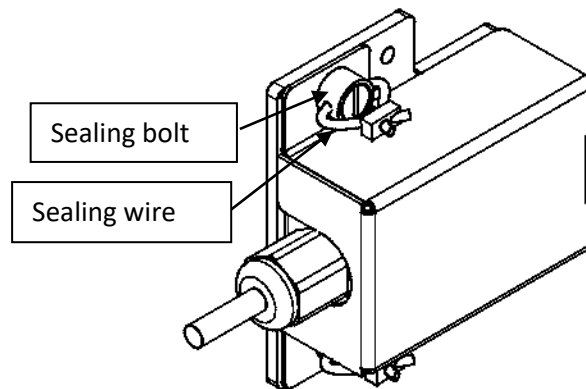

(b) Typical Bluetooth Device Sealing Method

FIGURE 6/9C/327 – 5

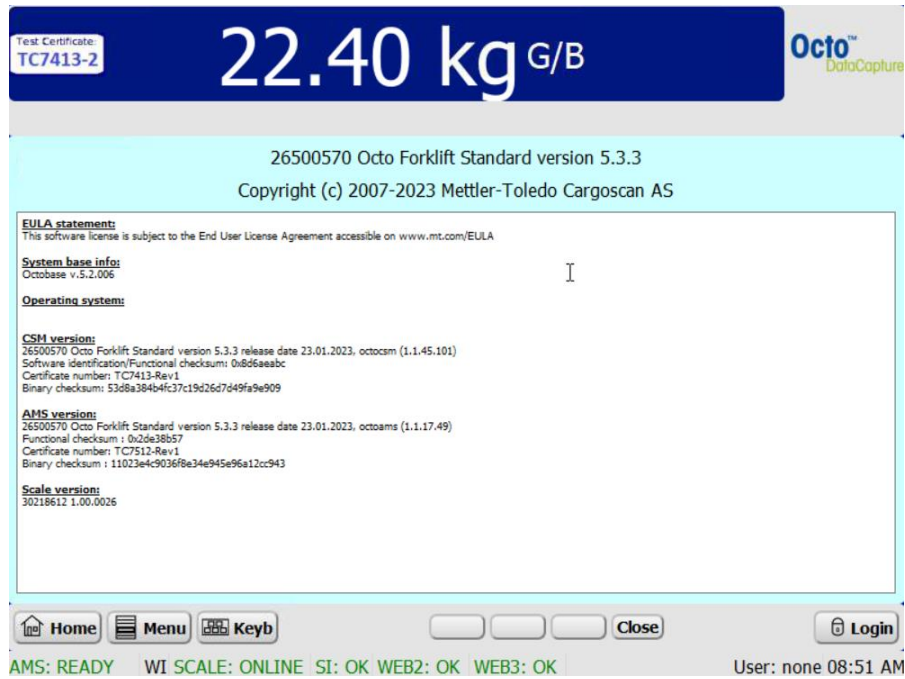

SmartPC Terminal Screen Showing Software Versions and Checksums

FIGURE 6/9C/327 – 6



Mettler Toledo ACM360 Bluetooth Device

~ End of Document ~