

Mill Cert & GA report (inspection).

DELIVERY ORDER

NO: 114325

DATE : 28/07/2017

GST NO : 000820973568

CUSTOMER CODE : I201E010 EZY TOOLS PTY LTD 17 DAVID STREET, FOOTSCRAY. 3011, AUSTRALIA TEL NO. : 613 9332 6636 FAX NO. : 613 9332 7637	DELIVERY ADDRESS 17 DAVID STREET, FOOTSCRAY. 3011, AUSTRALIA
TERMS : 30 DAYS	SUPPLY TOLERANCE : REFER TO OC

ITEM NO	ALUMINIUM SECTION			QUANTITY		UNIT IN METRE	PACKING (UNIT x BUNDLE)
	CODE	ALLOY/TEMPER	FINISH	UNIT (LGTH)	WEIGHT (KG)		

PO. NO. PI-220-190617

OC. NO. I14719

22/1	1.	AEZ212420 (IMP105)	6063/T5	YLW	937	2,139.021	4.340	5X185 3X4
10/1	2.	AEZ612385 (AVI531R)	6063/T5	NA	1,231	6,063.906	6.000	3X409 2X2
	3.	AEZ612381 (AVI532R)	6063/T5	MF	253	1,040.134	3.600	6X42 1X1
	4.	AEZ612423 (AV1457R)	6063/T5	NA	203	865.998	6.000	5X40 3X1
	5.	AEZ612423 (AV1457R)	6063/T5	YLW	125	533.250	6.000	5X25
	6.	AEZ612422 (IMP0090)	6063/T5	NA	86	568.632	6.000	4X21 1X2
	7.	AEZ612763 (E211-1045)	6063/T5	YLW	490	1,055.416	3.210	5X91 3X9 4X1 2X 2X1
	8.	AEZ612764 (E211-1046)	6063/T5	MF	178	513.277	3.010	5X35 3X1

ITEM : EIGHT (8) ONLY

INCOTERM: C&F MELBOURNE, AUSTRALIA

PACKING : 3503 PCS

No Claims will be entertained unless lodged within SEVEN (7) days from delivery

TOTAL : 3,503 12,779.634

WE HEREBY CONFIRM THAT THE GOODS RECEIVED HAVE BEING FULLY INSPECTED, ARE IN THE CORRECT QUANTITIES AND IN GOOD CONDITION.

FOR OFFICE USE ONLY :

for ALUMAC INDUSTRIES SDN. BHD.

Goods checked by :	
Vehicle No. :	
Goods sent by :	

CHOP AND SIGN

Authorised Signature

80331

ALUMAC INDUSTRIES SDN BHD

(300593-X)

Lot 8463, Kampong Jaya Industrial Area, 47000 Sungai Buloh,
Selangor Darul Ehsan, Malaysia.

Tel : +603 6156 9457

Fax : +603 6156 9357

Email : qa@alumac.com.my Website : www.alumac-aluminium.com

MILL CERTIFICATE OF ALUMINIUM EXTRUSION

28/Jul/17

MC-0004723

Customer Name **EZY TOOLS PTY LTD**
Order Confirmation No **I14719**
Delivery Order **I14325**
Purchase No **PI-220-190617**
Lot No **35971**
Product No **AEZ212420*YLV*4.3400**
Length **4.3400**
Section Weight **0.5260**
Alloy Group/Temper **6063/T5**
Remark

Chemical Composition

Element	Specification	CoA
Si	0.2 - 0.6	0.416
Fe	0 - 0.35	0.224
Cu	0 - 0.1	0.025
Mn	0 - 0.1	0.017
Mg	0.45 - 0.9	0.522
Zn	0 - 0.1	0.018
Ti	0 - 0.1	0.012
Cr	0 - 0.1	0.013
Ni	0 - 0.02	0.000
Al	90 - 100	98.760

This material complies with the chemical requirements of Aluminium Alloy 6063

Prepared by :
Name : NORA
Date : 28/Jul/17
(Q.A. Department)

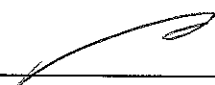
Verified by :
Name : Jimmy
Date : 28/Jul/17
(Q.A. Department)



- ALUMAC INDUSTRIES SDN BHD (300593-X)
- ALUMAC MARKETING SDN BHD (319139-H)
- ALUMAC TRADING SDN BHD (134954-V)

Lot 8463 Kampung Jaya Industrial Area,
47000 Sungai Buloh, Selangor, Malaysia
Tel : +603-6156 9457 Fax : +603-6156 9357

Doc. No : AL-FM-QA-011-02

OUTGOING QC INSPECTION REPORT

Page 1 of 1

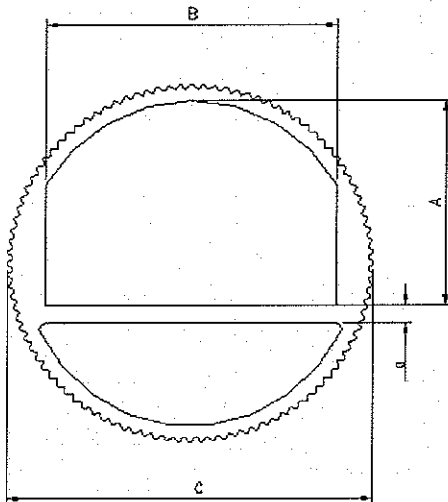

Date		07/28/17			PO No.		PI-220-190617		
DO No.		I14325			OC No.		I14719		
Section No. :		AEZ2-12420			Alloy/Temper :		6063/T5		
Quantity		937 pcs			Length		4.340 m	Finishing YLW	
Specification(mm)		1	2	3	4	5	Result	Remark	
QCP 10	A	18.30±0.23	18.30	18.32	18.32	18.31	18.32	OK	CALIPER
	B	25.50±0.31	25.25	25.27	25.25	25.28	25.27	OK	CALIPER
	C	32.00±0.40	31.96	31.95	31.99	31.90	31.94	OK	CALIPER
	a	1.50±0.18	1.45	1.42	1.43	1.47	1.45	OK	CALIPER
QCP 5		Hardness(HW)	12	13	13	11	12	OK	HARDNESS TESTER

****Note: This Report Is Based On Random Sampling Checks Only**

Prepared by: Swapon
Designation: MF Supervisor

Verified by: Jimmy
Designation: Senior QA Executive

ALUMAC INDUSTRIES SDN BHD

(300593-X)

Lot 8463, Kampong Jaya Industrial Area, 47000 Sungai Buloh,

Selangor Darul Ehsan, Malaysia.

Tel : +603 6156 9457

Fax : +603 6156 9357

Email : qa@alumac.com.my Website : www.alumac-aluminium.com

MILL CERTIFICATE OF ALUMINIUM EXTRUSION

28/Jul/17

MC-0004724

Customer Name **EZY TOOLS PTY LTD**
Order Confirmation No **I14719**
Delivery Order **I14325**
Purchase No **PI-220-190617**
Lot No **83575**
Product No **AEZ612385*NA*6.0000**
Length **6.0000**
Section Weight **0.8210**
Alloy Group/Temper **6063/T5**
Remark

Chemical Composition

Element	Specification	CoA
Si	0.2 - 0.6	0.437
Fe	0 - 0.35	0.215
Cu	0 - 0.1	0.036
Mn	0 - 0.1	0.041
Mg	0.45 - 0.9	0.516
Zn	0 - 0.1	0.039
Ti	0 - 0.1	0.011
Cr	0 - 0.1	0.016
Ni	0 - 0.02	0.000
Al	90 - 100	98.690

This material complies with the chemical requirements of Aluminium Alloy 6063

Prepared by :
Name : NORA
Date : 28/Jul/17
(Q.A. Department)

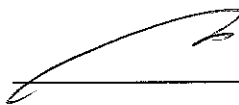
Verified by :
Name : Jimmy
Date : 28/Jul/17
(Q.A. Department)



ALUMAC INDUSTRIES SDN BHD (300593-X)
 ALUMAC MARKETING SDN BHD (319139-H)
 ALUMAC TRADING SDN BHD (134954-V)

Lot 8463 Kampung Jaya Industrial Area,
 47000 Sungai Buloh, Selangor, Malaysia
 Tel : +603-6156 9457 Fax : +603-6156 9357

Doc. No : AL-FM-QA-011-02

OUTGOING QC INSPECTION REPORT

Page 1 of 1

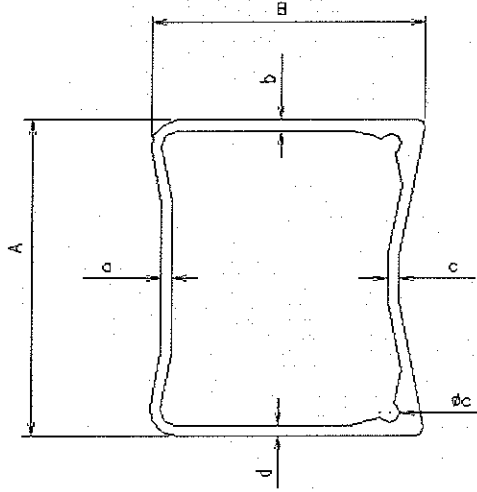

Date	07/28/17	PO No.	PI-220-190617
DO No.	I14325	OC No.	I14719
Section No. :	AEZ6-12385	Alloy/Temper :	6063/T5
Quantity	1231 pcs	Length	6.000 m
		Finishing	NA

		Specification(mm)	1	2	3	4	5	Result	Remark
QCP 10	A	50.30±0.61	50.28	50.27	50.27	50.25	50.26	OK	CALIPER
	B	40.00±0.36	40.05	40.06	40.01	40.05	40.04	OK	CALIPER
	C	3.00±0.15	3.08	3.02	3.01	3.06	3.05	OK	CALIPER
	a	1.50±0.18	1.36	1.37	1.37	1.36	1.36	OK	CALIPER
	b	1.70±0.18	1.77	1.76	1.75	1.79	1.74	OK	CALIPER
	c	1.60±0.18	1.64	1.66	1.61	1.68	1.63	OK	CALIPER
d	1.70±0.18	1.78	1.75	1.71	1.77	1.79	OK	CALIPER	
QCP 5	Hardness(HW)		11	11	11	11	11	OK	HARDNESS TESTER

****Note: This Report is Based On Random Sampling Checks Only**

Prepared by: Puspa
Designation: Line Leader

Verified by: Jimmy
Designation: Senior QA Executive

ALUMAC INDUSTRIES SDN BHD

(300593-X)

Lot 8463, Kampong Jaya Industrial Area, 47000 Sungai Buloh,
Selangor Darul Ehsan, Malaysia.

Tel : +603 6156 9457

Fax : +603 6156 9357

Email : qa@alumac.com.my Website : www.alumac-aluminium.com

MILL CERTIFICATE OF ALUMINIUM EXTRUSION

28/Jul/17
MC-0004725

Customer Name **EZY TOOLS PTY LTD**
Order Confirmation No **I14719**
Delivery Order **I14325**
Purchase No **PI-220-190617**
Lot No **35964**
Product No **AEZ612381*MF*3.6000**
Length **3.6000**
Section Weight **1.1420**
Alloy Group/Temper **6063/T5**
Remark

Chemical Composition

Element	Specification	CoA
Si	0.2 - 0.6	0.413
Fe	0 - 0.35	0.199
Cu	0 - 0.1	0.034
Mn	0 - 0.1	0.022
Mg	0.45 - 0.9	0.486
Zn	0 - 0.1	0.012
Ti	0 - 0.1	0.011
Cr	0 - 0.1	0.013
Ni	0 - 0.02	0.000
Al	90 - 100	98.810

This material complies with the chemical requirements of Aluminium Alloy 6063

Prepared by :

Name : NORA

Date : 28/Jul/17

(Q.A. Department)

Verified by :

Name : Jimmy

Date : 28/Jul/17

(Q.A. Department)



- ALUMAC INDUSTRIES SDN BHD (300593-X)
- ALUMAC MARKETING SDN BHD (319139-H)
- ALUMAC TRADING SDN BHD (134954-V)

Lot 8463 Kampung Jaya Industrial Area,
47000 Sungai Buloh, Selangor, Malaysia
Tel : +603-6156 9457 Fax : +603-6156 9357

Doc. No : AL-FM-QA-011-02

OUTGOING QC INSPECTION REPORT

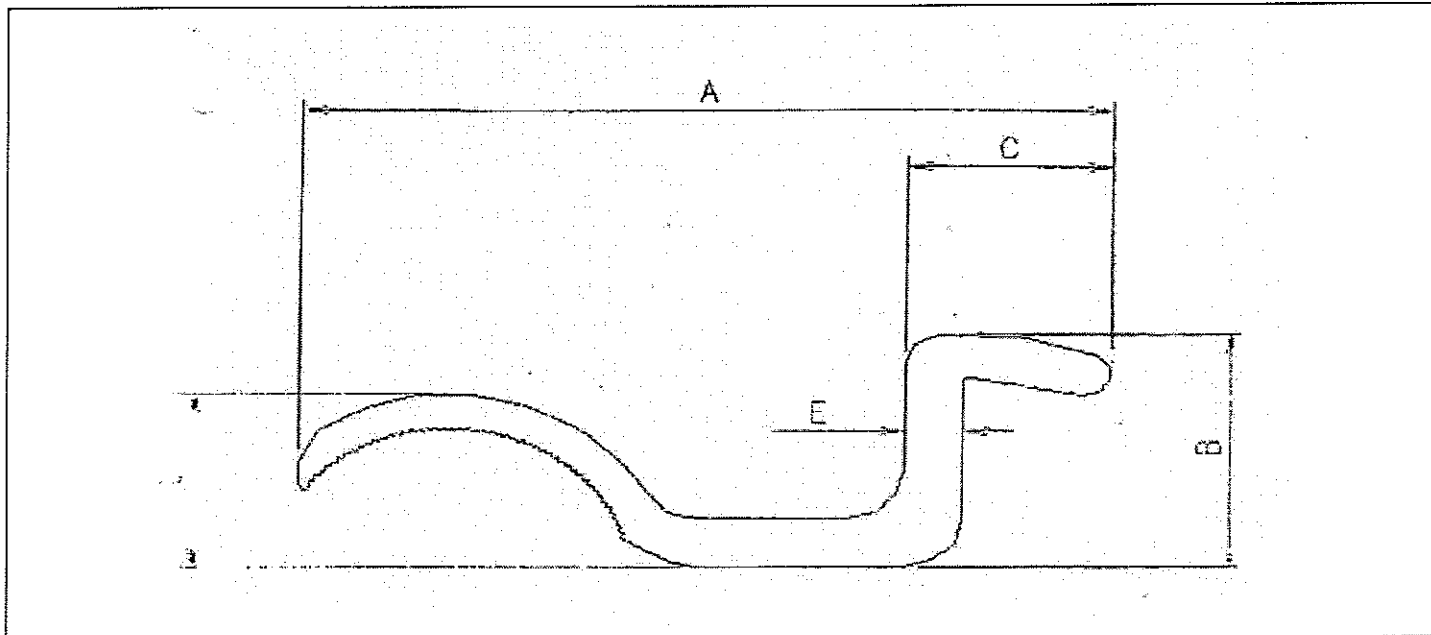

Date	07/28/17	PO No.	PI-220-190617
DO No.	I14325	OC No.	I14719
Section No. :	AEZ6-12381	Alloy/Temper :	6063/T5
Quantity	253	pcs	Length 3.600 m
			Finishing MF

	Specification(mm)	1	2	3	4	5	Result	Remark	
QCP 10	A	70.00±0.61	70.08	70.11	70.10	70.06	70.09	OK	CALIPER
	B	24.25±0.25	24.47	24.49	24.47	24.46	24.44	OK	CALIPER
	C	17.50±0.25	17.49	17.49	17.52	17.46	17.49	OK	CALIPER
	D	18.00±0.23	18.09	18.09	18.06	18.10	18.09	OK	CALIPER
	E	5.00±0.20	5.13	5.10	5.11	5.10	5.08	OK	CALIPER
QCP 5	Hardness(HW)	11	13	14	12	12	OK	HARDNESS TESTER	

****Note:** This Report Is Based On Random Sampling Checks Only

Prepared by: Swapon
Designation: MF Supervisor

Verified by: Jimmy
Designation: Senior QA Executive

ALUMAC INDUSTRIES SDN BHD

(300593-X)

Lot 8463, Kampong Jaya Industrial Area, 47000 Sungai Buloh,
Selangor Darul Ehsan, Malaysia.

Tel : +603 6156 9457

Fax : +603 6156 9357

Email : qa@alumac.com.my Website : www.alumac-aluminium.com

MILL CERTIFICATE OF ALUMINIUM EXTRUSION

28/Jul/17

MC-0004727

Customer Name **EZY TOOLS PTY LTD**
Order Confirmation No **I14719**
Delivery Order **I14325**
Purchase No **PI-220-190617**
Lot No **83471**
Product No **AEZ612423*NA*6.0000**
Length **6.0000**
Section Weight **0.7110**
Alloy Group/Temper **6063/T5**
Remark

Chemical Composition

Element	Specification	CoA
Si	0.2 - 0.6	0.426
Fe	0 - 0.35	0.189
Cu	0 - 0.1	0.033
Mn	0 - 0.1	0.023
Mg	0.45 - 0.9	0.529
Zn	0 - 0.1	0.008
Ti	0 - 0.1	0.011
Cr	0 - 0.1	0.015
Ni	0 - 0.02	0.000
Al	90 - 100	98.770

This material complies with the chemical requirements of Aluminium Alloy 6063

Prepared by :
Name : NORA
Date : 28/Jul/17
(Q.A. Department)

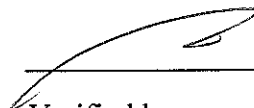
Verified by :
Name : Jimmy
Date : 28/Jul/17
(Q.A. Department)



- ALUMAC INDUSTRIES SDN BHD (300593-X)
- ALUMAC MARKETING SDN BHD (319139-H)
- ALUMAC TRADING SDN BHD (134954-V)

Lot 8463 Kampung Jaya Industrial Area,
 47000 Sungai Buloh, Selangor, Malaysia
 Tel : +603-6156 9457 Fax : +603-6156 9357

Doc. No : AL-FM-QA-011-02

OUTGOING QC INSPECTION REPORT

Page 1 of 1

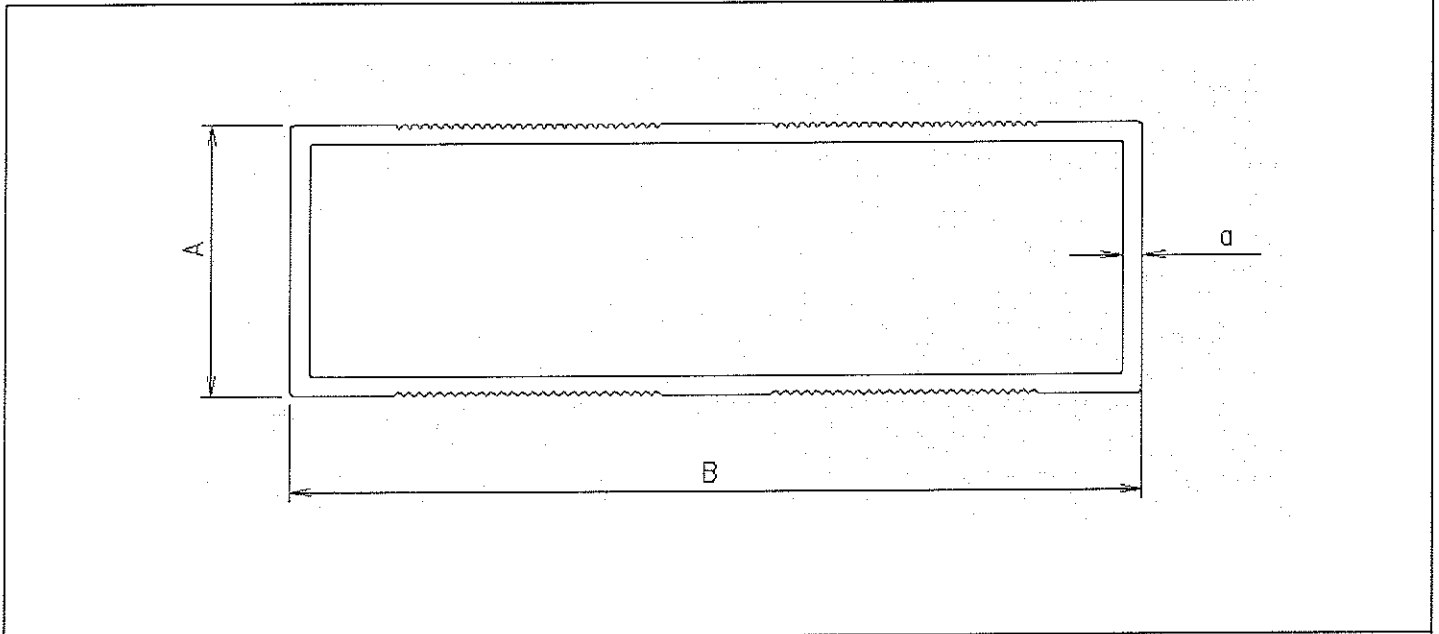

Date		07/28/17			PO No.		PI-220-190617				
DO No.		I14325			OC No.		I14719				
Section No. :		AEZ6-12423			Alloy/Temper :		6063/T5				
Quantity		203		pcs	Length		6.000		m	Finishing	NA
QCP 10	Specification(mm)								Result	Remark	
	A	19.00±0.23	19.08	19.06	19.10	19.07	19.09	OK	CALIPER		
	B	70.00±0.61	70.09	70.07	70.08	70.08	70.09	OK	CALIPER		
QCP 5	a	1.60±0.18	1.47	1.48	1.48	1.47	1.47	OK	CALIPER		
	Hardness(HW)	12	12	12	12	12	12	OK	HARDNESS TESTER		

**Note: This Report Is Based On Random Sampling Checks Only

Prepared by: Puspa
 Designation: Line Leader

Verified by: Jimmy
 Designation: Senior QA Executive

ALUMAC INDUSTRIES SDN BHD

(300593-X)

Lot 8463, Kampong Jaya Industrial Area, 47000 Sungai Buloh,
Selangor Darul Ehsan, Malaysia.

Tel : +603 6156 9457

Fax : +603 6156 9357

Email : qa@alumac.com.my Website : www.alumac-aluminium.com

MILL CERTIFICATE OF ALUMINIUM EXTRUSION

28/Jul/17

MC-0004726

Customer Name **EZY TOOLS PTY LTD**
Order Confirmation No **I14719**
Delivery Order **I14325**
Purchase No **PI-220-190617**
Lot No **E7E0388A**
Product No **AEZ612423*YLV*6.0000**
Length **6.0000**
Section Weight **0.7110**
Alloy Group/Temper **6063/T5**
Remark

Chemical Composition

Element	Specification	CoA
Si	0.2 - 0.6	0.430
Fe	0 - 0.35	0.170
Cu	0 - 0.1	0.009
Mn	0 - 0.1	0.030
Mg	0.45 - 0.9	0.480
Zn	0 - 0.1	0.009
Ti	0 - 0.1	0.009
Cr	0 - 0.1	0.009
Ni	0 - 0.02	0.000
Al	90 - 100	98.854

This material complies with the chemical requirements of Aluminium Alloy 6063



Prepared by :
Name : NORA
Date : 28/Jul/17
(Q.A. Department)

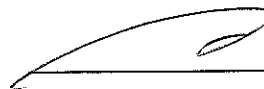

Verified by :
Name : Jimmy
Date : 28/Jul/17
(Q.A. Department)



- ALUMAC INDUSTRIES SDN BHD (300593-X)
- ALUMAC MARKETING SDN BHD (319139-H)
- ALUMAC TRADING SDN BHD (134954-V)

Lot 8463 Kampung Jaya Industrial Area,
47000 Sungai Buloh, Selangor, Malaysia
Tel : +603-6156 9457 Fax : +603-6156 9357

Doc. No : AL-FM-QA-011-02

OUTGOING QC INSPECTION REPORT

Page 1 of 1

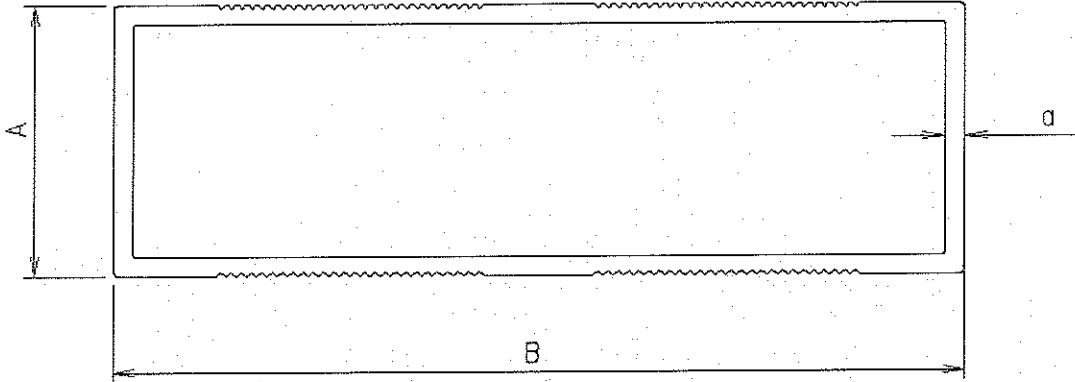

Date	07/28/17	PO No.	PI-220-190617
DO No.	I14325	OC No.	I14719
Section No. :	AEZ6-12423	Alloy/Temper :	6063/T5
Quantity	125 pcs	Length	6.000 m Finishing YLW

		Specification(mm)	1	2	3	4	5	Result	Remark
QCP 10	A	19.00±0.23	19.00	19.01	19.00	19.03	19.00	OK	CALIPER
	B	70.00±0.61	69.86	69.88	69.88	69.89	69.83	OK	CALIPER
	a	1.60±0.18	1.49	1.47	1.47	1.48	1.49	OK	CALIPER
QCP 5		Hardness(HW)	11.00	12.00	13.00	13.00	11.00	OK	HARDNESS TESTER

****Note: This Report Is Based On Random Sampling Checks Only**

Prepared by: Swapon
Designation: MF Supervisor

Verified by: Jimmy
Designation: Senior QA Executive

ALUMAC INDUSTRIES SDN BHD

(300593-X)

Lot 8463, Kampong Jaya Industrial Area, 47000 Sungai Buloh,
Selangor Darul Ehsan, Malaysia.

Tel : +603 6156 9457

Fax : +603 6156 9357

Email : qa@alumac.com.my Website : www.alumac-aluminium.com

MILL CERTIFICATE OF ALUMINIUM EXTRUSION

28/Jul/17
MC-0004728

Customer Name **EZY TOOLS PTY LTD**
Order Confirmation No **I14719**
Delivery Order **I14325**
Purchase No **PI-220-190617**
Lot No **83575**
Product No **AEZ612422*NA*6.0000**
Length **6.0000**
Section Weight **1.1020**
Alloy Group/Temper **6063/T5**
Remark

Chemical Composition

Element	Specification	CoA
Si	0.2 - 0.6	0.437
Fe	0 - 0.35	0.215
Cu	0 - 0.1	0.036
Mn	0 - 0.1	0.041
Mg	0.45 - 0.9	0.516
Zn	0 - 0.1	0.039
Ti	0 - 0.1	0.011
Cr	0 - 0.1	0.016
Ni	0 - 0.02	0.000
Al	90 - 100	98.690

This material complies with the chemical requirements of Aluminium Alloy 6063



Prepared by :
Name : NORA
Date : 28/Jul/17
(Q.A. Department)



Verified by :
Name : Jimmy
Date : 28/Jul/17
(Q.A. Department)



- ALUMAC INDUSTRIES SDN BHD (300593-X)
- ALUMAC MARKETING SDN BHD (319139-H)
- ALUMAC TRADING SDN BHD (134954-V)

Lot 8463 Kampung Jaya Industrial Area,
47000 Sungai Buloh, Selangor, Malaysia
Tel : +603-6156 9457 Fax : +603-6156 9357

OUTGOING QC INSPECTION REPORT

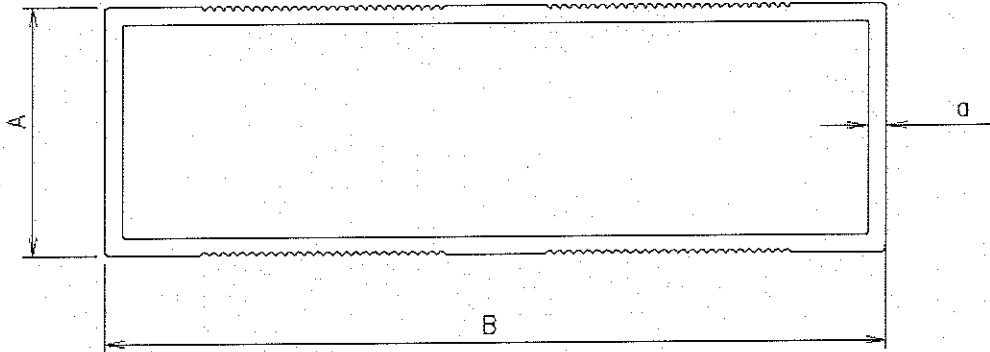

Date	07/28/17		PO No.	PI-220-190617					
DO No.	I14325		OC No.	I14719					
Section No. :	AEZ6-12422		Alloy/Temper :	6063/T5					
Quantity	86	pcs	Length	6.000	m	Finishing	NA		
		Specification(mm)	1	2	3	4	5	Result	Remark
QCP 10	A	28.50±0.31	28.60	28.59	28.59	28.61	28.60	OK	CALIPER
	B	82.50±0.61	82.58	82.54	82.54	82.55	82.55	OK	CALIPER
	a	2.00±0.18	1.91	1.91	1.91	1.91	1.91	OK	CALIPER
QCP 5		Hardness(HW)	12	12	12	12	12	OK	HARDNESS TESTER

**Note: This Report Is Based On Random Sampling Checks Only

Prepared by: Puspa
Designation: Line Leader

Verified by: Jimmy
Designation: Senior QA Executive

ALUMAC INDUSTRIES SDN BHD

(300593-X)

Lot 8463, Kampong Jaya Industrial Area, 47000 Sungai Buloh,
Selangor Darul Ehsan, Malaysia.

Tel : +603 6156 9457

Fax : +603 6156 9357

Email : qa@alumac.com.my Website : www.alumac-aluminium.com

MILL CERTIFICATE OF ALUMINIUM EXTRUSION

27/Jul/17
MC-0004729

Customer Name **EZY TOOLS PTY LTD**
Order Confirmation No **I14719**
Delivery Order **I14325**
Purchase No **PI-220-190617**
Lot No **E7E0388A**
Product No **AEZ612763*YLV*3.2100**
Length **3.2100**
Section Weight **0.6710**
Alloy Group/Temper **6063/T5**
Remark

Chemical Composition

Element	Specification	CoA
Si	0.2 - 0.6	0.430
Fe	0 - 0.35	0.170
Cu	0 - 0.1	0.009
Mn	0 - 0.1	0.030
Mg	0.45 - 0.9	0.480
Zn	0 - 0.1	0.009
Ti	0 - 0.1	0.009
Cr	0 - 0.1	0.009
Ni	0 - 0.02	0.000
Al	90 - 100	98.854

This material complies with the chemical requirements of Aluminium Alloy 6063

Prepared by :
Name : NORA
Date : 27/Jul/17
(Q.A. Department)

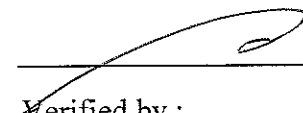
Verified by :
Name : Jimmy
Date : 27/Jul/17
(Q.A. Department)



ALUMAC INDUSTRIES SDN BHD (300593-X)
 ALUMAC MARKETING SDN BHD (319139-H)
 ALUMAC TRADING SDN BHD (134954-V)

Lot 8463 Kampung Jaya Industrial Area,
 47000 Sungai Buloh, Selangor, Malaysia
 Tel : +603-6156 9457 Fax : +603-6156 9357

Doc. No : AL-FM-QA-011-02

OUTGOING QC INSPECTION REPORT

Page 1 of 1

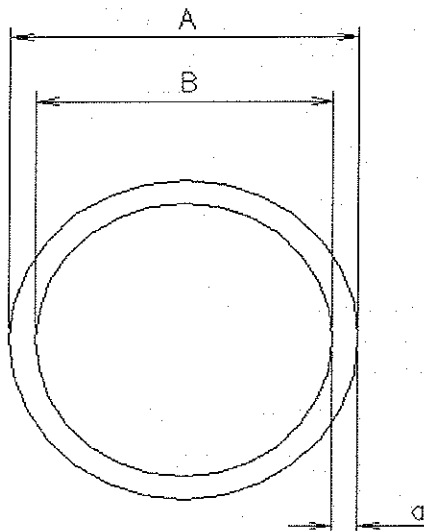

Date		07/28/17			PO No.		PI-220-190617			
DO No.		I14325			OC No.		I14719			
Section No. :		AEZ6-12763			Alloy/Temper :		6063/T5			
Quantity		490 pcs			Length		3.210 m		Finishing	YLW
		Specification(mm)	1	2	3	4	5	Result	Remark	
QCP 10	A	34.00±0.31	34.02	34.05	34.06	34.05	34.07	OK	CALIPER	
	B	29.00±0.31	29.05	29.07	29.08	29.07	29.06	OK	CALIPER	
	a	2.50±0.25	2.56	2.51	2.55	2.57	2.50	OK	CALIPER	
QCP 5		Hardness(HW)	11	11	12	13	12	OK	HARDNESS TESTER	

****Note: This Report Is Based On Random Sampling Checks Only**

Prepared by: Swapon
 Designation: MF Supervisor

Verified by: Jimmy
 Designation: Senior QA Executive

ALUMAC INDUSTRIES SDN BHD

(300593-X)

Lot 8463, Kampong Jaya Industrial Area, 47000 Sungai Buloh,

Selangor Darul Ehsan, Malaysia.

Tel : +603 6156 9457

Fax : +603 6156 9357

Email : qa@alumac.com.my Website : www.alumac-aluminium.com

MILL CERTIFICATE OF ALUMINIUM EXTRUSION

28/Jul/17

MC-0004730

Customer Name **EZY TOOLS PTY LTD**
Order Confirmation No **I14719**
Delivery Order **I14325**
Purchase No **PI-220-190617**
Lot No **83530**
Product No **AEZ612764*MF*3.0100**
Length **3.0100**
Section Weight **0.9580**
Alloy Group/Temper **6063/T5**
Remark

Chemical Composition

Element	Specification	CoA
Si	0.2 - 0.6	0.448
Fe	0 - 0.35	0.184
Cu	0 - 0.1	0.041
Mn	0 - 0.1	0.012
Mg	0.45 - 0.9	0.530
Zn	0 - 0.1	0.019
Ti	0 - 0.1	0.011
Cr	0 - 0.1	0.008
Ni	0 - 0.02	0.000
Al	90 - 100	98.750

This material complies with the chemical requirements of Aluminium Alloy 6063

Prepared by :

Name : NORA

Date : 28/Jul/17

(Q.A. Department)

Verified by :

Name : Jimmy

Date : 28/Jul/17

(Q.A. Department)



- ALUMAC INDUSTRIES SDN BHD (300593-X)
- ALUMAC MARKETING SDN BHD (319139-H)
- ALUMAC TRADING SDN BHD (134954-V)

Lot 8463 Kampung Jaya Industrial Area,
47000 Sungai Buloh, Selangor, Malaysia
Tel : +603-6156 9457 Fax : +603-6156 9357

Doc. No : AL-FM-QA-011-02

OUTGOING QC INSPECTION REPORT

Page 1 of 1

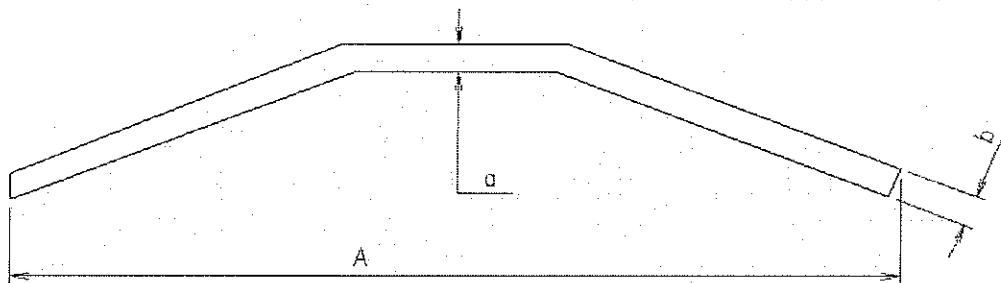

Date	07/28/17	PO No.	PI-220-190617
DO No.	I14325	OC No.	I14719
Section No. :	AEZ6-12764	Alloy/Temper :	6063/T5
Quantity	178 pcs	Length	3.010 m
		Finishing	MF

		Specification(mm)	1	2	3	4	5	Result	Remark
QCP 10	A	98.90±0.61	98.70	98.70	98.71	98.70	98.70	OK	CALIPER
	a	3.31±0.20	3.20	3.21	3.20	3.20	3.19	OK	CALIPER
	b	3.60±0.20	3.50	3.58	3.58	3.53	3.56	OK	CALIPER
QCP 5		Hardness(HW)	12.00	12.00	13.00	11.00	11.00	OK	HARDNESS TESTER

****Note: This Report Is Based On Random Sampling Checks Only**

Prepared by: Swapon
Designation: MF Supervisor

Verified by: Jimmy
Designation: Senior QA Executive