



Australian Government
Department of Industry, Science,
Energy and Resources

National
Measurement
Institute

NMI R 46-1-2

Active-energy electricity meters

Part 1: Metrological and
technical requirements

Part 2: Metrological controls
and performance tests

June 2022

www.measurement.gov.au

© Commonwealth of Australia (2021)

NMI R 46-1-2

First edition

— June 2022

National Measurement Institute
Bradfield Road, Lindfield, NSW 2070

T: +61 2 8467 3600

F: +61 2 8467 3610

W: www.measurement.gov.au

Preface

It is Australian Government policy to harmonise Australian standards with international metrological requirements to the greatest possible extent. This document presents one pathway for the pattern approval of electricity meters.

This pathway is new and is based on the International Organisation of Legal Metrology Recommendation 46, OIML R 46 (2012).

Other pathways may be available. At the time of publication, the following pathways exist:

1. NMI M 6-1 and NMI M 6-2
2. NMI M 13-1 and NMI M 13-2
3. NMI R 46-1-2 (this document) and NMI R 46-3

1 Scope and Application

2 Scope

This document contains requirements for the metrological control of active-energy electricity meters (meters) intended for use for trade. The requirements apply to watt hour meters operating on alternating current circuits, used for single-rate or multi-rate operation, in single or polyphase installations, having a nominal operating frequency of 50 Hz and a connection voltage not exceeding 600 V.

In-field performance requirements are not addressed in this document.

2.1 Application

This document describes a pathway¹ for approval of a pattern.

The National Measurement Institute (NMI) reserves the right to vary or interpret requirements if it is deemed appropriate to support new or different technologies or applications.

3 Contents

NMI R 46-1-2 (June 2022) is a modified version of OIML R 46-1/-2 (2012) *Active Electrical Energy Meters. Part 1: Metrological and Technical Requirements and Part 2: Metrological Control and Performance Tests* published by the International Organisation of Legal Metrology (OIML). These modifications are listed in clause 4.

4 Amendments and Interpretations

Amendments and interpretations have been made to the 2012 edition of OIML R 46-1/-2. These are described in the table below. Amendments shown in [blue text](#) have been made in the document body in [blue text](#). Text that has been deleted is marked in [strike-out](#).

Clause	Details
General	All references in this document to 'this Recommendation' shall be taken to refer to NMI R 46-1-2.
General	In Australia 'type' approval (or examination) is referred to as 'pattern' approval (or examination). The two terms refer to the same concept.
General	All references in this document to the 'issuing authority', or 'national authority' shall be taken to refer to the Chief Metrologist.
General	Text that refers to decisions by national authorities or regional legislation (or similar) have been modified, deleted or clarified.
General	Some references to verification and in-service inspections have been deleted as they are not within scope of this document.
2.2.19	The alternative term for 'base maximum permissible error' has been modified to 'base mpe'.
3.2; Table 1	For current, notes have been added to clarify the relationship between transitional current and other commonly used current parameters: basic current for direct connected meters and nominal current for transformer-operated meters.
3.2; Table 1	For temperature, the limits have been modified for Australian conditions. The lower temperature option of +5 °C has been deleted, and the upper temperature options of +30 °C and +40 °C have been deleted.
3.3.6.2; Table 5	Deleted durability from the disturbances table (see 3.8 for more information).
3.4	Manufacturers shall specify interval data storage capabilities and these are to be listed on Certificates of Approval.
3.5	Meter markings modified to specify and clarify information that must be marked on every meter. This includes requiring markings to be visible when installed.

¹ See the preface for information on other pathways.

3.6.1	Added that levels of authorized access may be specified for a Utility Meter Verifiers under their conditions of appointment.
3.6.8	Clarified that a meter that has been modified or repaired requires verification.
3.8	Durability requirements removed because there is no agreed national standard for durability.
4.1	Deleted references to durability in the required documentation (see 3.8 for more information).
6.2.1; Table 10	For the determination of initial intrinsic error, 10 I_r is specified as a mandatory test point.
6.4.16.1	For the dry heat test, the possible temperatures of 40 °C and 55 °C have been deleted in line with modifications to the temperature limits in 3.2, Table 1.
6.4.16.2	For the cold test, the possible temperature of -10 °C has been deleted in line with modifications to the temperature limits in 3.2, Table 1.
6.4.17	Deleted durability test (see 3.8 for more information).
8	Verification requirements have been deleted. The verification requirements in Australia are specified in the National Instrument Test Procedure, NITP 14.

**INTERNATIONAL
RECOMMENDATION**

OIML R 46-1/-2
Edition 2012 (E)

**Active Electrical Energy Meters.
Part 1: Metrological and technical requirements
Part 2 Metrological controls and performance tests**

Compteurs actifs d'énergie électrique.
Partie 1: Exigences métrologies et techniques
Partie 2: Contrôles métrologiques et essais de performance



Contents

Foreword.....	7
Part 1 Metrological and technical requirements	8
1 Scope	8
2 Terms and definitions	8
2.1 Meters and their constituents	8
2.1.1 electricity meter	8
2.1.2 interval meter	8
2.1.3 prepayment meter	8
2.1.4 multi-tariff meter, multi-rate meter	8
2.1.5 direct connected meter	8
2.1.6 transformer operated meter	8
2.1.7 electromechanical meter	8
2.1.8 static meter.....	9
2.1.9 measuring element	9
2.1.10 current circuit.....	9
2.1.11 voltage circuit	9
2.1.12 indicating device, display.....	9
2.1.13 register	9
2.1.14 primary rated register.....	9
2.1.15 register multiplier.....	9
2.1.16 meter constant	9
2.1.17 test output.....	9
2.1.18 adjustment device	9
2.1.19 ancillary device	9
2.1.20 sub-assembly.....	10
2.2 Metrological characteristics.....	10
2.2.1 current (I)	10
2.2.2 starting current (I_{st})	10
2.2.3 minimum current (I_{min}).....	10
2.2.4 transitional current (I_{tr}).....	10
2.2.5 maximum current (I_{max})	10
2.2.6 voltage (U)	10
2.2.7 nominal voltage (U_{nom})	10
2.2.8 frequency (f).....	10
2.2.9 nominal frequency (f_{nom})	10
2.2.10 harmonic	10
2.2.11 sub-harmonic	10
2.2.12 harmonic number	10
2.2.13 distortion factor (d)	10
2.2.14 power factor (PF)	11
2.2.15 active power.....	11
2.2.16 active energy	11
2.2.17 relative error of indication	11
2.2.18 maximum permissible error mpe	11
2.2.19 base maximum permissible error	11

2.2.20	maximum permissible error shift	12
2.2.21	intrinsic error	12
2.2.22	initial intrinsic error	12
2.2.23	influence quantity	12
2.2.24	influence factor	12
2.2.25	disturbance	12
2.2.26	rated operating condition	12
2.2.27	reference condition	13
2.2.28	accuracy class	13
2.2.29	durability	13
2.2.30	fault	13
2.2.31	significant fault	13
2.2.32	checking facility	13
2.2.33	primary register	14
2.2.34	bi-directional (energy) flow	14
2.2.35	positive-direction only (energy) flow	14
2.2.36	uni-directional (energy) flow	14
2.2.37	positive (energy) flow	14
2.2.38	negative (energy) flow	14
2.2.39	reverse (energy) flow	14
2.2.40	legally relevant	14
3	Metrological requirements	14
3.1	Units of measurement	14
3.2	Rated operating conditions	14
3.3	Accuracy requirements	16
3.3.1	General	16
3.3.2	Direction of energy flow	17
3.3.3	Base maximum permissible errors	17
3.3.4	No load	18
3.3.5	Allowed effects of influence quantities	18
3.3.6	Allowed effects of disturbances	20
3.4	Requirements for interval and multi-tariff meters	22
3.5	Meter markings	22
3.6	Protection of metrological properties	23
3.6.1	General	23
3.6.2	Software identification	23
3.6.3	Software protection	24
3.6.4	Parameter protection	24
3.6.5	Separation of electronic devices and sub-assemblies	25
3.6.6	Separation of software parts	25
3.6.7	Storage of data, transmission via communication systems	26
3.6.8	Maintenance and re-configuration	27
3.6.9	Checking facility event record	28
3.7	Suitability for use	28
3.7.1	Readability of result	28
3.7.2	Testability	29
3.8	Durability	29
3.9	Presumption of compliance	29

Part 2 Metrological controls and performance tests.....	30
4 Type approval.....	30
4.1 Documentation.....	30
4.2 Type definition.....	31
4.2.1 Type test sampling.....	31
4.3 Validation procedure.....	31
5 Test program.....	34
6 Test procedures for type approval.....	34
6.1 Test conditions.....	34
6.2 Tests for compliance with maximum permissible errors.....	35
6.2.1 Determination of initial intrinsic error.....	35
6.2.2 Self-heating.....	36
6.2.3 Starting current.....	36
6.2.4 Test of no-load condition.....	37
6.2.5 Meter constants.....	38
6.3 Tests for influence quantities.....	38
6.3.1 General.....	38
6.3.2 Temperature dependence.....	39
6.3.3 Load balance.....	39
6.3.4 Voltage variation.....	39
6.3.5 Frequency variation.....	40
6.3.6 Harmonics in voltage and current.....	40
6.3.7 Tilt.....	42
6.3.8 Severe voltage variations.....	42
6.3.9 One or two phases interrupted.....	42
6.3.10 Sub-harmonics in the AC current circuit.....	43
6.3.11 Harmonics in the AC current circuit.....	44
6.3.12 Reversed phase sequence (any two phases interchanged).....	45
6.3.13 Continuous (DC) magnetic induction of external origin.....	45
6.3.14 Magnetic field (AC, power frequency) of external origin.....	45
6.3.15 Electromagnetic fields.....	45
6.3.16 DC in the AC current circuit.....	47
6.3.17 High-order harmonics.....	48
6.4 Tests for disturbances.....	48
6.4.1 General instructions for disturbance tests.....	48
6.4.2 Magnetic field (AC, power frequency) of external origin.....	48
6.4.3 Electrostatic discharge.....	48
6.4.4 Fast transients.....	49
6.4.5 Voltage dips and interruptions.....	50
6.4.6 Radiated, radio frequency (RF), electromagnetic fields.....	50
6.4.7 Surges on AC mains power lines.....	50
6.4.8 Damped oscillatory waves immunity test.....	51
6.4.9 Short-time overcurrent.....	52
6.4.10 Impulse voltage.....	52
6.4.11 Earth fault.....	54
6.4.12 Operation of ancillary devices.....	55
6.4.13 Mechanical tests.....	55

6.4.14	Protection against solar radiation.....	56
6.4.15	Protection against ingress of dust.....	56
6.4.16	Climatic tests	57
6.4.17	Durability test	59
7	Type evaluation and approval.....	59
8	Verification.....	59
8.1	General	59
8.2	Testing.....	60
8.2.1	Calibration status	60
8.2.2	Conformity check	60
8.2.3	Warming up.....	60
8.2.4	Minimum test program	60
8.2.5	Sealing	61
8.3	Reference conditions for initial and subsequent verifications in a laboratory	61
8.4	Additional requirements for statistical verifications.....	62
8.4.1	Lot.....	62
8.4.2	Samples.....	62
8.4.3	Statistical testing	62
8.5	Additional requirements for statistical in-service inspections	63
Annex A	Bibliography.....	64
Annex B	69
Estimation of combined errors.....		69
B.1	Estimate of combined maximum permissible error based on the requirements of this Recommendation.....	69
B.2	Estimation of combined error based on type test results and specific conditions.....	69
B.2.1	Method 1.....	69
B.2.2	Method 2.....	70
Annex C.....		71
Legislative matters.....		71
C.1	Legislative considerations	71
C.1.1	Choice of accuracy class.....	71
C.1.2	Matters not covered by the scope of this Recommendation.....	72

Foreword

The International Organization of Legal Metrology (OIML) is a worldwide, intergovernmental organization whose primary aim is to harmonize the regulations and metrological controls applied by the national metrological services, or related organizations, of its Member States. The main categories of OIML publications are:

- **International Recommendations (OIML R)**, which are model regulations that establish the metrological characteristics required of certain measuring instruments and which specify methods and equipment for checking their conformity. OIML Member States shall implement these Recommendations to the greatest possible extent;
- **International Documents (OIML D)**, which are informative in nature and which are intended to harmonize and improve work in the field of legal metrology;
- **International Guides (OIML G)**, which are also informative in nature and which are intended to give guidelines for the application of certain requirements to legal metrology;
- **International Basic Publications (OIML B)**, which define the operating rules of the various OIML structures and systems; and

OIML Draft Recommendations, Documents and Guides are developed by Project Groups linked to Technical Committees or Subcommittees which comprise representatives from OIML Member States. Certain international and regional institutions also participate on a consultation basis. Cooperative agreements have been established between the OIML and certain institutions, such as ISO and the IEC, with the objective of avoiding contradictory requirements. Consequently, manufacturers and users of measuring instruments, test laboratories, etc. may simultaneously apply OIML publications and those of other institutions.

International Recommendations, Documents, Guides and Basic Publications are published in English (E) and translated into French (F) and are subject to periodic revision.

Additionally, the OIML publishes or participates in the publication of **Vocabularies (OIML V)** and periodically commissions legal metrology experts to write **Expert Reports (OIML E)**. Expert Reports are intended to provide information and advice, and are written solely from the viewpoint of their author, without the involvement of a Technical Committee or Subcommittee, nor that of the CIML. Thus, they do not necessarily represent the views of the OIML.

This publication - reference OIML R 46-1/-2, edition 2012 (E) – was developed by OIML TC 12 *Instruments for measuring electrical quantities*. It was approved for final publication by the International Committee of Legal Metrology at its 47th meeting in Bucharest, Romania, in October 2012. It was submitted by the 14th International Conference in 2012.

OIML Publications may be downloaded from the OIML web site in the form of PDF files. Additional information on OIML Publications may be obtained from the Organization's headquarters:

Bureau International de Métrologie Légale
11, rue Turgot - 75009 Paris - France
Telephone: 33 (0)1 48 78 12 82
Fax: 33 (0)1 42 82 17 27
E-mail: biml@oiml.org
Internet: www.oiml.org

Part 1 Metrological and technical requirements

1 Scope

This Recommendation specifies the metrological and technical requirements applicable to electricity meters subject to legal metrological controls. The requirements are to be applied during type approval, verification, and re-verification. They also apply to modifications that may be made to existing approved devices.

The provisions set out here apply only to active electrical energy meters; other meter types may be addressed in future versions of this Recommendation. Meters can be direct connected for system voltages up to 690 V, or transformer operated.

2 Terms and definitions

The terminology used in this Recommendation conforms to the *International Vocabulary of Basic and General Terms in Metrology (VIM)* [3] and the *International Vocabulary of Legal Metrology (VIML)* [4]. Terminology from OIML International Document D 11 *General requirements for electronic measuring instruments* [1], and OIML International Document D 31 *General requirements for software controlled measuring instruments* [2] is also applicable particularly for 3.6 *Protection of metrological properties* and the associated validation procedures in 4.3. In addition, for the purposes of this Recommendation, the following definitions shall apply.

2.1 Meters and their constituents

2.1.1 electricity meter

instrument intended to measure electrical energy continuously by integrating power with respect to time and to store the result

Note: It is recognized that “continuously” may also cover meters with a sampling rate sufficiently high to fulfil the requirements of this Recommendation.

2.1.2 interval meter

electricity meter which displays and stores the result as measured in predetermined time intervals

2.1.3 prepayment meter

electricity meter intended to allow electrical energy to be delivered up to a predetermined amount

Note 1: Such a meter measures energy continuously and stores and displays the measured energy.

Note 2: National authorities may specify requirements in relation to prepayment meters.

2.1.4 multi-tariff meter,

multi-rate meter

electricity meter intended to measure and display electrical energy where energy will have more than one tariff rate

Note: The tariff rate may be determined by time, load or some other quantity.

2.1.5 direct connected meter

meter intended for use by direct connection to the circuit(s) being measured, without the use of external device(s) such as instrument transformer(s)

2.1.6 transformer operated meter

meter intended for use with one or more external instrument transformers

2.1.7 electromechanical meter

meter in which currents in fixed coils react with the currents induced in the conducting moving element, generally (a) disk(s), which causes their movement proportional to the energy to be measured

[IEC 62052-11:2003, 3.1.1]

2.1.8 static meter

meter in which current and voltage act on solid state (electronic) elements to produce an output proportional to the energy to be measured

[IEC 62052-11:2003, 3.1.2]

2.1.9 measuring element

part of the meter that transforms a current and a voltage into a signal proportional to the power and or energy

Note: A measuring element can be based on an electromagnetic, electrical or an electronic principle.

2.1.10 current circuit

internal connections of the meter and part of the measuring element through which flows the current of the circuit to which the meter is connected

[IEC 62052-11:2003, 3.2.6]

2.1.11 voltage circuit

internal connections of the meter, part of the measuring element and, in the case of static meters, part of the power supply, supplied with the voltage of the circuit to which the meter is connected

[IEC 62052-11:2003, 3.2.7]

**2.1.12 indicating device,
display**

part of the meter that displays the measurement results either continuously or on demand

Note: An indicating device may also be used to display other relevant information.

2.1.13 register

part of the meter that stores the measured values.

Note: The register may be an electromechanical device or an electronic device and may be integral to the indicating device.

2.1.14 primary rated register

(for transformer operated meters)

register where the scale factor(s) due to the used instrument transformer(s) is considered such that the measured energy on the primary side of the instrument transformer(s) is indicated

2.1.15 register multiplier

constant with which the register reading shall be multiplied to obtain the value of the metered energy

2.1.16 meter constant

value expressing the relation between the energy registered by the meter and the corresponding value of the test output

2.1.17 test output

device which can be used for testing the meter, providing pulses or the means to provide pulses corresponding to the energy measured by the meter

2.1.18 adjustment device

device or function incorporated in the meter that allows the error curve to be shifted with a view to bringing errors (of indication) within the maximum permissible errors

2.1.19 ancillary device

device intended to perform a particular function, directly involved in elaborating, transmitting or displaying measurement results

[OIML V 1:2013, 5.06]

Note: An ancillary device is not part of the basic metrology function of a meter.

2.1.20 sub-assembly

part of a device having a recognizable function of its own

2.2 Metrological characteristics

2.2.1 current (I)

value of the electrical current flowing through the meter

Note: The term “current” in this Recommendation indicates r.m.s. (root mean square) values unless otherwise specified.

2.2.2 starting current (I_{st})

lowest value of current specified by the manufacturer at which the meter should register electrical energy at unity power factor and, for poly-phase meters, with balanced load

2.2.3 minimum current (I_{min})

lowest value of current at which the meter is specified by the manufacturer to meet the accuracy requirements

2.2.4 transitional current (I_{tr})

value of current at and above which the meter is specified by the manufacturer to lie within the smallest maximum permissible error corresponding to the accuracy class of the meter

2.2.5 maximum current (I_{max})

highest value of current at which the meter is specified by the manufacturer to meet the accuracy requirements

2.2.6 voltage (U)

value of the electrical voltage supplied to the meter

Note: The term “voltage” in this Recommendation indicates r.m.s. (root mean square) values unless otherwise specified.

2.2.7 nominal voltage (U_{nom})

voltage specified by the manufacturer for normal operation of the meter

Note: Meters designed for operation across a range of voltages may have several nominal voltage values.

2.2.8 frequency (f)

frequency of the voltage (and current) supplied to the meter

2.2.9 nominal frequency (f_{nom})

frequency of the voltage (and current) specified by the manufacturer for normal operation of the meter

2.2.10 harmonic

part of a signal that has a frequency that is an integer multiple of the fundamental frequency of the signal

Note: The fundamental frequency is generally the nominal frequency (f_{nom})

2.2.11 sub-harmonic

frequency that is an integer fraction of the fundamental frequency of the signal, that is, $1/n$ times the fundamental frequency, where n is an integer greater than 1

2.2.12 harmonic number

integer number used to identify a harmonic

Note: The harmonic number is the ratio of the frequency of a harmonic to the fundamental frequency of the signal.

2.2.13 distortion factor (d)

ratio of the r.m.s. value of the harmonic content to the r.m.s. value of the fundamental term

Note 1: The harmonic content is obtained e.g. by subtracting from a non-sinusoidal alternating quantity its fundamental term.

Note 2: The distortion factor is usually expressed as a percentage. It is equivalent to THD, total harmonic distortion.

2.2.14 power factor (PF)

ratio of the active power to the apparent power

Note: At sinusoidal and either one-phase or symmetrical three-phase conditions, the power factor = $\cos \Phi$ = the cosine of the phase difference Φ between voltage U and current I .

2.2.15 active power

rate at which energy is transported

Note: In an electrical system active power is measured as the time mean of the instantaneous power, which is calculated at each instant as the product of voltage and current:

$$p(t) = u(t) \cdot i(t)$$

where:

u is the instantaneous voltage,

i is the instantaneous current,

p is the instantaneous power.

At sinusoidal conditions active power is the product of the r.m.s. values of current and voltage and the cosine of the phase angle between them, calculated for each phase. It is usually expressed in kW:

$$P = U_{r.m.s.} \cdot I_{r.m.s.} \cdot \cos \Phi .$$

2.2.16 active energy

active power integrated over time

$$\text{Note 1: } E(T) = \int_0^T p(t) \cdot dt = \int_0^T u(t) \cdot i(t) \cdot dt$$

where:

E is the active energy. Other symbols are as defined in 2.2.15

Note 2: Active energy is usually expressed in kWh or MWh. Refer to 3.1 for requirements on units of measurement.

2.2.17 relative error of indication

indication minus reference quantity value, divided by the reference quantity value

Note 1: The relative error is usually expressed as a percentage of the reference quantity value.

Note 2: Since this Recommendation deals only with relative error, the short form “error” is used for relative error.

2.2.18 maximum permissible error

mpe

extreme value of measurement error, with respect to a known reference quantity value, permitted by specifications or regulations for a given measurement, measuring instrument or measuring system

Note 1: Usually, the term “maximum permissible errors” or “limits of errors” is used where there are two extreme values.

Note 2: The term “tolerance” should not be used to designate “maximum permissible error”.

[OIML V 2-200:2012, 4.26]

Note 3: In this Recommendation, the maximum permissible error is a combination of the base maximum permissible error and the maximum permissible error shift as described in Annex B.

Note 4: For the application of this Recommendation, “specifications or regulations” means: the provisions contained in this Recommendation, and the terms “measuring instrument” and “measuring system” mean: electricity meter.

2.2.19 base maximum permissible error

[base](#) mpe

extreme value of the error of indication of a meter, permitted by this Recommendation, when the current and power factor are varied within the intervals given by the rated operating conditions, and when the meter is otherwise operated at reference conditions

Note: In this Recommendation, the maximum permissible error is a combination of the base maximum permissible error and the maximum permissible error shift as described in Annex B.

2.2.20 maximum permissible error shift

extreme value of the change in error of indication of a meter, permitted by this Recommendation, when a single influence factor is taken from its value at reference conditions and varied within the rated operating conditions

Note 1: For each influence factor there is one corresponding maximum permissible error shift.

Note 2: In this Recommendation, the maximum permissible error is a combination of the base maximum permissible error and the maximum permissible error shift as described in Annex B.

2.2.21 intrinsic error

error of a measuring instrument, determined under reference conditions

[OIML V 1:2013, 0.06]

2.2.22 initial intrinsic error

intrinsic error of a measuring instrument as determined prior to performance tests and durability evaluations

[OIML V 1:2013, 5.11]

2.2.23 influence quantity

quantity that, in a direct measurement, does not affect the quantity that is actually measured, but affects the relation between the indication and the measurement result

[OIML V 2-200:2012, 2.52]

Note 1: The concept of influence quantity is understood to include values associated with measurement standards, reference materials and reference data upon which the result of a measurement may depend, as well as phenomena such as short-term measuring instrument fluctuations and quantities such as ambient temperature, barometric pressure and humidity.

Note 2: In the GUM [5], the concept 'influence quantity' is defined as in the second edition of the VIM, covering not only the quantities affecting the measuring system, as in the definition above, but also those quantities that affect the quantities actually measured. Also, in the GUM this concept is not restricted to direct measurements. [OIML V 2-200:2012, 2.52, Note 2]

2.2.24 influence factor

influence quantity having a value which ranges within the rated operating conditions of a measuring instrument

[OIML V 1:2013, 5.18]

2.2.25 disturbance

influence quantity having a value within the limits specified in this Recommendation, but outside the specified rated operating conditions of a measuring instrument

[OIML V 1:2013, 5.19]

Note: An influence quantity is a disturbance if the rated operating conditions for that influence quantity are not specified.

2.2.26 rated operating condition

operating condition that must be fulfilled during measurement in order that a measuring instrument or measuring system perform as designed

Note 1: Rated operating conditions generally specify intervals of values for a quantity being measured and for any influence quantity.

[OIML V 2-200:2012, 4.9]

Note 2: For the application of this Recommendation, the terms “measuring instrument” and “measuring system” mean: electricity meter.

2.2.27 reference condition

operating condition prescribed for evaluating the performance of a measuring instrument or measuring system or for comparison of measurement results

Note 1: Reference operating conditions specify intervals of values of the measurand and of the influence quantities.

Note 2: In IEC 60050-300, item 311-06-02, the term “reference condition” refers to an operating condition under which the specified instrumental measurement uncertainty is the smallest possible.

[OIML V 2-200:2012, 4.11]

Note 3: For the application of this Recommendation, the terms “measuring instrument” and “measuring system” mean: electricity meter.

2.2.28 accuracy class

class of measuring instruments or measuring systems that meet stated metrological requirements that are intended to keep measurement errors or instrumental measurement uncertainties within specified limits under specified operating conditions

[OIML V 2-200:2012, 4.25]

Note: In this Recommendation, the stated metrological requirements for accuracy class include permissible responses to disturbances.

2.2.29 durability

ability of the measuring instrument to maintain its performance characteristics over a period of use

[OIML V 1:2013, 5.15]

2.2.30 fault

difference between the error of indication and the intrinsic error of a measuring instrument

Note 1: Principally, a fault is the result of an undesired change of data contained in or flowing through a measuring instrument.

Note 2: From the definition it follows that a "fault" is a numerical value which is expressed either in a unit of measurement or as a relative value, for instance as a percentage.

[OIML D11:2004, 3.9]

Note 3: In this Recommendation, the above definition does not apply to the term ‘earth fault’, in which the word ‘fault’ has its usual dictionary meaning.

2.2.31 significant fault

fault exceeding the applicable fault limit value

[OIML D11:2004, 3.10]

Note: The following are also considered to be significant faults:

- a change larger than the critical change value (see 3.3.6.2) has occurred in the measurement registers due to disturbances;
- the functionality of the meter has become impaired.

2.2.32 checking facility

facility that is incorporated in a measuring instrument and which enables significant faults to be detected and acted upon

Note 1: “Acted upon” refers to any adequate response by the measuring instrument (luminous signal, acoustic signal, prevention of the measurement process, etc.).

[OIML V 1:2013, 5.07]

Note 2: For the application of this Recommendation, the term “measuring instrument” means: electricity meter and the action following the detection of a significant fault should be either to stop measuring and record

the time and duration of the stop, or record the time and duration of the fault and the amount of energy measured during the fault.

Note 3 Faults that are detected and acted upon by means of a checking facility shall not be considered as significant faults.

2.2.33 primary register

register that is subject to the requirements of this Recommendation

2.2.34 bi-directional (energy) flow

capability of the meter to measure energy flow in both directions (positive and negative)

2.2.35 positive-direction only (energy) flow

capability of the meter to measure energy flow in only one direction (positive direction)

2.2.36 uni-directional (energy) flow

capability of the meter to measure energy flow regardless of the direction of energy flow

2.2.37 positive (energy) flow

direction of energy flow towards the consumer

2.2.38 negative (energy) flow

(for bi-directional and uni-directional meters)

direction of energy flow opposite to positive

Note: For positive-direction only, the opposite direction is termed reverse energy flow (see 2.2.39).

2.2.39 reverse (energy) flow

(for positive-direction only meters)

direction of flow in the opposite direction to positive

2.2.40 legally relevant

attribute of a part of a measuring instrument, device or software subject to legal control

[OIML V 1:2013, 4.08]

3 Metrological requirements

3.1 Units of measurement

The units of measurement for active electrical energy shall be one of the following units: Wh, kWh, MWh, GWh.

3.2 Rated operating conditions

Rated operating conditions are specified in Table 1.

Table 1 Rated operating conditions

Condition or influence quantity	Values, ranges																																																		
Frequency	$f_{nom} \pm 2 \%$ where f_{nom} is to be specified by the manufacturer. If the manufacturer specifies more than one nominal frequency, the rated operating conditions shall be the combination of all $f_{nom} \pm 2 \%$ intervals.																																																		
Voltage	$U_{nom} \pm 10 \%$ where U_{nom} is to be specified by the manufacturer. Meters designed to operate across a range of voltages shall have applicable U_{nom} values specified by the manufacturer. If the manufacturer specifies more than one nominal voltage the rated operating conditions shall be the combination of all $U_{nom} \pm 10 \%$ intervals.																																																		
Current	<p>I_{st} to I_{max}</p> <p>I_{max}, I_{tr}, I_{min} and I_{st} are to be specified by the manufacturer in accordance with the following:</p> <table border="1" data-bbox="424 734 1241 987"> <thead> <tr> <th data-bbox="424 734 651 831">Direct connected</th> <th colspan="4" data-bbox="659 734 1241 786">Accuracy class</th> </tr> <tr> <th data-bbox="424 792 651 831"></th> <th data-bbox="659 792 778 831">A</th> <th data-bbox="786 792 906 831">B</th> <th data-bbox="914 792 1034 831">C</th> <th data-bbox="1042 792 1161 831">D</th> </tr> </thead> <tbody> <tr> <td data-bbox="424 837 651 875">I_{max}/I_{tr}</td> <td data-bbox="659 837 778 875">≥ 50</td> <td data-bbox="786 837 906 875">≥ 50</td> <td data-bbox="914 837 1034 875">≥ 50</td> <td data-bbox="1042 837 1161 875">≥ 50</td> </tr> <tr> <td data-bbox="424 882 651 920">I_{max}/I_{min}</td> <td data-bbox="659 882 778 920">≥ 100</td> <td data-bbox="786 882 906 920">≥ 125</td> <td data-bbox="914 882 1034 920">≥ 250</td> <td data-bbox="1042 882 1161 920">≥ 250</td> </tr> <tr> <td data-bbox="424 927 651 965">I_{max}/I_{st}</td> <td data-bbox="659 927 778 965">≥ 1000</td> <td data-bbox="786 927 906 965">≥ 1250</td> <td data-bbox="914 927 1034 965">≥ 1250</td> <td data-bbox="1042 927 1161 965">≥ 1250</td> </tr> </tbody> </table> <p data-bbox="424 994 1441 1077">Note: Other standards such as NMI M 6-1 and Australian Standards based on IEC standards use basic current (I_b) as a parameter for direct connected meters. Generally, the relationship with the transitional current is $I_b = 10 I_{tr}$.</p> <table border="1" data-bbox="424 1093 1241 1346"> <thead> <tr> <th data-bbox="424 1093 651 1189">Transformer-operated</th> <th colspan="4" data-bbox="659 1093 1241 1144">Accuracy class</th> </tr> <tr> <th data-bbox="424 1151 651 1189"></th> <th data-bbox="659 1151 778 1189">A</th> <th data-bbox="786 1151 906 1189">B</th> <th data-bbox="914 1151 1034 1189">C</th> <th data-bbox="1042 1151 1161 1189">D</th> </tr> </thead> <tbody> <tr> <td data-bbox="424 1196 651 1234">I_{max}/I_{tr}</td> <td data-bbox="659 1196 778 1234">≥ 24</td> <td data-bbox="786 1196 906 1234">≥ 24</td> <td data-bbox="914 1196 1034 1234">≥ 24</td> <td data-bbox="1042 1196 1161 1234">≥ 24</td> </tr> <tr> <td data-bbox="424 1240 651 1279">I_{max}/I_{min}</td> <td data-bbox="659 1240 778 1279">≥ 60</td> <td data-bbox="786 1240 906 1279">$\geq 120^{(1)}$</td> <td data-bbox="914 1240 1034 1279">≥ 120</td> <td data-bbox="1042 1240 1161 1279">≥ 120</td> </tr> <tr> <td data-bbox="424 1285 651 1323">I_{max}/I_{st}</td> <td data-bbox="659 1285 778 1323">≥ 480</td> <td data-bbox="786 1285 906 1323">≥ 600</td> <td data-bbox="914 1285 1034 1323">≥ 1200</td> <td data-bbox="1042 1285 1161 1323">≥ 1200</td> </tr> </tbody> </table> <p data-bbox="424 1352 1241 1391">Note ⁽¹⁾: ≥ 60 for class B transformer operated electromechanical meters.</p> <p data-bbox="424 1413 1441 1496">Note: Other standards such as NMI M 6-1 and Australian Standards based on IEC standards use nominal current (I_n) as a parameter for transformer-operated meters. Generally, the relationship with the transitional current is $I_n = 20 I_{tr}$.</p>	Direct connected	Accuracy class					A	B	C	D	I_{max}/I_{tr}	≥ 50	≥ 50	≥ 50	≥ 50	I_{max}/I_{min}	≥ 100	≥ 125	≥ 250	≥ 250	I_{max}/I_{st}	≥ 1000	≥ 1250	≥ 1250	≥ 1250	Transformer-operated	Accuracy class					A	B	C	D	I_{max}/I_{tr}	≥ 24	≥ 24	≥ 24	≥ 24	I_{max}/I_{min}	≥ 60	$\geq 120^{(1)}$	≥ 120	≥ 120	I_{max}/I_{st}	≥ 480	≥ 600	≥ 1200	≥ 1200
Direct connected	Accuracy class																																																		
	A	B	C	D																																															
I_{max}/I_{tr}	≥ 50	≥ 50	≥ 50	≥ 50																																															
I_{max}/I_{min}	≥ 100	≥ 125	≥ 250	≥ 250																																															
I_{max}/I_{st}	≥ 1000	≥ 1250	≥ 1250	≥ 1250																																															
Transformer-operated	Accuracy class																																																		
	A	B	C	D																																															
I_{max}/I_{tr}	≥ 24	≥ 24	≥ 24	≥ 24																																															
I_{max}/I_{min}	≥ 60	$\geq 120^{(1)}$	≥ 120	≥ 120																																															
I_{max}/I_{st}	≥ 480	≥ 600	≥ 1200	≥ 1200																																															
Power factor	From 0.5 inductive to 1 to 0.8 capacitive, except for classes C and D where the operating range is from 0.5 inductive to 1 to 0.5 capacitive. For bi-directional meters the power factor range limits are valid in both directions.																																																		
Temperature	From lower temperature limit to upper temperature limit as specified by manufacturer. The manufacturer shall specify the lower temperature limit from the values: $-55 \text{ }^\circ\text{C}$, $-40 \text{ }^\circ\text{C}$, $-25 \text{ }^\circ\text{C}$, $-10 \text{ }^\circ\text{C}$, $+5 \text{ }^\circ\text{C}$. The manufacturer shall specify the upper temperature limit from the values: $+30 \text{ }^\circ\text{C}$, $+40 \text{ }^\circ\text{C}$, $+55 \text{ }^\circ\text{C}$, $+70 \text{ }^\circ\text{C}$.																																																		

Condition or influence quantity	Values, ranges							
Humidity and water	<p>With respect to humidity, the manufacturer shall specify the environment class for which the instrument is intended:</p> <p>H1: enclosed locations where the instruments are not subjected to condensed water, precipitation, or ice formations,</p> <p>H2: enclosed locations where the instruments may be subjected to condensed water, to water from sources other than rain and to ice formations,</p> <p>H3: open locations with average climatic conditions.</p>							
Connection modes	<p>The manufacturer shall specify whether the meter is intended for direct connection, connection through current transformers or through current and voltage transformers.</p> <p>The manufacturer shall specify the connection mode(s), the number of measurement elements of the meter and the number of phases of the electric system for which the meter is intended.</p> <p>A meter in accordance with this Recommendation may be (but is not limited to) one or more of the following:</p> <table border="1" data-bbox="424 837 1294 1330"> <thead> <tr> <th data-bbox="424 837 1294 891">Description</th> </tr> </thead> <tbody> <tr> <td data-bbox="424 891 1294 945">single-phase two-wire, 1 element</td> </tr> <tr> <td data-bbox="424 945 1294 1025">single-phase three-wire, 1 element (applicable only for balanced and symmetrical voltages)</td> </tr> <tr> <td data-bbox="424 1025 1294 1079">single-phase three-wire, 2-element</td> </tr> <tr> <td data-bbox="424 1079 1294 1133">three-phase four-wire 3-element</td> </tr> <tr> <td data-bbox="424 1133 1294 1214">three-phase three-wire 2-element (applicable only in cases where leakage currents can be ruled out)</td> </tr> <tr> <td data-bbox="424 1214 1294 1330">two-phase three-wire 2-element (intended for operation on two phases of a three-phase service. Can also be a three-phase meter operated as two-phase three-wire)</td> </tr> </tbody> </table> <p>The manufacturer may specify alternative connection modes for poly-phase meters. These alternative connection mode(s) shall also be part(s) of the operating conditions.</p>	Description	single-phase two-wire, 1 element	single-phase three-wire, 1 element (applicable only for balanced and symmetrical voltages)	single-phase three-wire, 2-element	three-phase four-wire 3-element	three-phase three-wire 2-element (applicable only in cases where leakage currents can be ruled out)	two-phase three-wire 2-element (intended for operation on two phases of a three-phase service. Can also be a three-phase meter operated as two-phase three-wire)
Description								
single-phase two-wire, 1 element								
single-phase three-wire, 1 element (applicable only for balanced and symmetrical voltages)								
single-phase three-wire, 2-element								
three-phase four-wire 3-element								
three-phase three-wire 2-element (applicable only in cases where leakage currents can be ruled out)								
two-phase three-wire 2-element (intended for operation on two phases of a three-phase service. Can also be a three-phase meter operated as two-phase three-wire)								
Tilt	Mounting position as specified by the manufacturer ± 3 degrees. If no mounting position is given, any mounting position is allowed.							
Harmonics	The voltage and current shall be allowed to deviate from the sinusoidal form, as given by the requirements in 3.3.5, Table 4 “Harmonics in voltage and current circuits”.							
Load balance	The load balance shall be allowed to vary from fully balanced conditions to current in only one current circuit for poly-phase meters and for single-phase 3-wire meters.							
<p><i>Note:</i> National authorities or regional legislation may specify certain values for various rated operating conditions. See Annex C.</p>								

3.3 Accuracy requirements

3.3.1 General

The manufacturer shall specify the accuracy class of the meter to be one of A, B, C or D.

Note: Class B is the lowest accuracy class recommended for large consumers, i.e. where consumption exceeds 5000 kWh/year, or another value chosen by the appropriate authority.

The meter shall be designed and manufactured such that its error does not exceed the maximum permissible error for the specified class under rated operating conditions.

The meter shall be designed and manufactured such that, when exposed to disturbances, significant faults do not occur.

A fault is not considered a significant fault if it is detected and acted upon by means of a checking facility. The meter shall clearly indicate if such an event has occurred (cf. 2.2.31 and 2.2.32).

Note: The indication could take the form of a light flashing in the event of a fault.

3.3.2 Direction of energy flow

Where a manufacturer has specified that a meter shall be capable of bidirectional energy flow, the meter shall correctly handle both positive and negative mean energy flow and the meter shall fulfil the requirement of this Recommendation for energy flow in both directions. The polarity of energy flow shall be defined by the manufacturer's connection instructions for the meter. Mean energy flow refers to the active power integrated over at least one cycle of the nominal frequency.

A meter shall fall into at least one of the following categories:

- single-register, bi-directional, where the meter is specified as capable of measuring both positive and negative mean energy flow, and where the net result will be placed in a single register;
- two-register, bi-directional, where the meter is specified as capable of measuring both positive and negative mean energy flow, as defined by the connection of the meter, and where the positive result and negative result are placed in different registers;
- single-register, positive direction only, where the meter is specified as capable of measuring and registering only positive mean energy flow. It may inherently, by its design, register only positive mean energy flow or it may be equipped with a reverse running detent;
- single-register, uni-directional, where the meter is specified as capable of measuring and registering the absolute value of the mean energy flow. Normally such a meter will register all energy as consumed energy independent of the true direction of the energy flow or of how the meter is connected.

For bi-directional meters, energy registration shall occur in the correct register when the direction of flow changes.

Note 1: The terms "single-register" and "two-register" in the list above refer to the basic energy register(s) only. A meter may have other registers, e.g. for storage of tariff and/or phase information.

Note 2: ~~The national authority may determine what meter types and calculation methods are appropriate.~~

3.3.3 Base maximum permissible errors

The intrinsic error (expressed in percent) shall be within the base maximum permissible error stated in Table 2 when the current and power factor are varied within the limits given by Table 2 (operating range), and when the meter is otherwise operated at reference conditions. ~~National authorities may specify the base maximum permissible errors for subsequent verification and in-service inspections.~~

Table 2 Base maximum permissible errors and no load requirements

Quantity		Base maximum permissible errors (%) for meters of class			
Current I	Power factor	A	B	C	D
$I_{tr} \leq I \leq I_{max}$	Unity	± 2.0	± 1.0	± 0.5	± 0.2
	0.5 inductive to 1 to 0.8 capacitive (1)	± 2.5	± 1.5	± 0.6	± 0.3

$I_{\min} \leq I < I_{tr}$	Unity	± 2.5	± 1.5	± 1.0	± 0.4
	0.5 inductive to 1 to 0.8 capacitive	± 2.5	± 1.8	± 1.0	± 0.5
$I_{st} \leq I < I_{\min}$	Unity	$\pm 2.5 \cdot I_{\min}/I$	$\pm 1.5 \cdot I_{\min}/I$	$\pm 1.0 \cdot I_{\min}/I$	$\pm 0.4 \cdot I_{\min}/I$
⁽⁴⁾ The national authority may specify that the power factor requirement is from 0.5 inductive to 1 to 0.5 capacitive.					

Note: The combined maximum permissible error (CMPE) and the combined maximum error (CME) resulting from the type evaluation can be calculated as presented in Annex B (B.1 and B.2). ~~Regional or national authorities may require this CME to fulfil the CMPE or to meet other limits (not related to the CMPE) determined by the regional or national authorities.~~

3.3.4 No load

No significant energy shall be registered under conditions of no load (refer to section 6.2.4 for the test procedure).

Note: The meter is always allowed to stop for currents below I_{st} .

3.3.5 Allowed effects of influence quantities

The temperature coefficient of the meter shall fulfil the requirements of Table 3 when the meter is otherwise operated at reference conditions.

Table 3 Limits for temperature coefficient of error

Influence quantity	Power factor	Limits for temperature coefficient (%/K) for meters of class			
		A	B	C	D ⁽¹⁾
Temperature coefficient (%/K), over any interval, within the temperature range, which is not less than 15K and not greater than 23K, for current $I_{tr} \leq I \leq I_{max}$	1	± 0.1	± 0.05	± 0.03	± 0.01
	0.5 inductive	± 0.15	± 0.07	± 0.05	± 0.02
⁽¹⁾ These values are doubled below $-10\text{ }^\circ\text{C}$.					

When the load current and power factor are held constant at a point within the rated operating range with the meter otherwise operated at reference conditions, and when any single influence quantity is varied from its value at reference conditions to its extreme values defined in Table 4, the variation of error shall be such that the additional percentage error is within the corresponding limit of error shift stated in Table 4. The meter shall continue to function after the completion of each of these tests.

Table 4 Limit of error shift due to influence quantities

Influence quantity	Value	Test clause	Value of current	Power factor	Limit of error shift (%) for meters of class			
					A	B	C	D
Self-heating	Continuous current at I_{max}	6.2.2	I_{max}	1; 0.5 inductive	± 1	± 0.5	± 0.25	± 0.1
Load balance ⁽¹⁾	Current in only one current circuit	6.3.3	$I_{tr} \leq I \leq I_{max}$	1	$\pm 1.5^{(2)}$	± 1.0	± 0.7	± 0.3
				0.5 inductive	$\pm 2.5^{(2)}$	± 1.5	± 1	± 0.5
Voltage variation ⁽³⁾	$U_{nom} \pm 10\%$	6.3.4	$I_{tr} \leq I \leq I_{max}$	1	$\pm 1.0^{(9)}$	± 0.7	± 0.2	± 0.1
				0.5 inductive	± 1.5	± 1.0	± 0.4	± 0.2
		6.3.5		1	± 0.8	± 0.5	± 0.2	± 0.1

Frequency variation	$f_{nom} \pm 2\%$		$I_{tr} \leq I \leq I_{max}$	0.5 inductive	± 1.0	± 0.7	± 0.2	± 0.1
Harmonics in voltage and current circuits	d is $0 - 40\% I$, $0 - 5\% U$ ⁽⁴⁾	6.3.6	$I_{tr} \leq I \leq I_{max}$	1	$\pm 1.0^{(5)}$	± 0.6	± 0.3	± 0.2
Tilt	≤ 3 degrees	6.3.7	$I_{tr} \leq I \leq I_{max}$	1	± 1.5	± 0.5	± 0.4	n/a
Severe voltage variations	$0.8 U_{nom} \leq U < 0.9 U_{nom}$; $1.1 U_{nom} < U \leq 1.15 U_{nom}$	6.3.8	$10 I_{tr}$	1	$\pm 1.5^{(11)}$	± 1	± 0.6	± 0.3
	$U < 0.8 U_{nom}$				+10 to -100			
One or two phases interrupted ⁽⁶⁾	One or two phases removed	6.3.9	$10 I_{tr}$	1	± 4	± 2	± 1	± 0.5
Sub-harmonics in the AC current circuit	Current signal of equal power with sub-harmonics present	6.3.10	$10 I_{tr}$	1	± 3	± 1.5	± 0.75	± 0.5
Harmonics in the AC current circuit	Phase-fired at 90 degrees	6.3.11	$10 I_{tr}$	1	± 1	± 0.8	± 0.5	± 0.4
Reversed phase sequence	Any two phases interchanged	6.3.12	$10 I_{tr}$	1	± 1.5	± 1.5	± 0.1	± 0.05
Continuous (DC) magnetic induction of external origin ⁽¹⁰⁾	200 mT at 30 mm from core surface ⁽¹⁰⁾	6.3.13	$10 I_{tr}$	1	± 3	± 1.5	± 0.75	± 0.5
Magnetic field (AC, power frequency) of external origin.	400 A/m	6.3.14	$10 I_{tr}, I_{max}$	1	± 2.5	± 1.3	± 0.5	± 0.25
Radiated, RF, electromagnetic fields	$f = 80$ to 6000 MHz, Field strength ≤ 10 V/m	6.3.15.1	$10 I_{tr}$	1	± 3	± 2	± 1	± 1
Conducted disturbances, induced by radio frequency fields ⁽⁷⁾	$f = 0.15$ to 80 MHz, Amplitude ≤ 10 V	6.3.15.2	$10 I_{tr}$	1	± 3	± 2	± 1	± 1
DC in the AC current circuit ⁽⁸⁾	Sinusoidal current, twice amplitude, half-wave rectified; $I \leq I_{max}/\sqrt{2}$	6.3.16	$I_{max}/\sqrt{2}$	1	± 6	± 3	± 1.5	± 1
High-order harmonics	Superimposed: $0.02 U_{nom}$; $0.1 I_{tr}$; $15 f_{nom}$ to $40 f_{nom}$	6.3.17	I_{tr}	1	± 1	± 1	± 0.5	± 0.5

⁽¹⁾ Only for poly-phase and single-phase 3-wire meters.
⁽²⁾ The error shift may exceed the value specified in the table provided the error is within $\pm 2.5\%$.
⁽³⁾ For poly-phase meters the requirement is for symmetrical voltage variations.

- (4) As long as the r.m.s. current is not higher than I_{\max} and the peak value of the current is not higher than $1.41 \cdot I_{\max}$. Furthermore, the amplitude of individual harmonic components shall not exceed (I_1 / h) for current and $(0.12 \cdot U_1 / h)$ for voltage, where h is the harmonic order.
- (5) In the case of electromechanical meters, the error shift may exceed the value specified in the table provided the error is within $\pm 3.0 \%$.
- (6) Only for poly-phase meters. Two phases interrupted is only for those connection modes where a missing phase means that energy can be delivered. This requirement applies only to fault conditions of the network, not for an alternative connection mode. A poly-phase meter which is powered from only one of its phases shall not have the voltage of that phase interrupted for the purposes of this test.
- (7) Direct or indirect, conducted disturbances induced by radio-frequency fields.
- (8) Only for direct connected meters. ~~National authorities may determine if this requirement is applicable.~~
- (9) For class A, electromechanical meters, the requirement is not applicable below $10 I_{tr}$.
- (10) Manufacturers may additionally include an alarm upon detection of a continuous (DC) magnetic induction of greater than 200 mT. ~~National authorities may select a lower magnetic induction for national requirements.~~
- (11) For electromechanical meters, this value is doubled.

3.3.6 Allowed effects of disturbances

3.3.6.1 General

The meter shall withstand disturbances which may be encountered under conditions of normal use; as stated in 3.3.1, no significant fault shall occur for any of the disturbances listed in Table 5.

3.3.6.2 Disturbances

An error shift larger than that prescribed in Table 5 constitutes a significant fault. If a meter is operated under the conditions outlined in Table 5 and no current is applied, a change in the registers or pulses of the test output shall not be considered as a significant fault if the change in the registers or equivalent energy of the test output, expressed in kWh, is less than $m \cdot U_{nom} \cdot I_{\max} \cdot 10^{-6}$ (critical change value), where m is the number of measuring elements, U_{nom} is expressed in volts and I_{\max} is expressed in amperes.

Table 5 Disturbances

Disturbance quantity	Test Clause	Level of disturbance	Allowed effects	Limit of error shift (%) for meters of class			
				A	B	C	D
Magnetic field (AC, power frequency) of external origin.	6.4.2	1000 A/m, 3 s	No significant fault.	-	-	-	-
Electrostatic discharges	6.4.3	8 kV contact discharge; 15 kV air discharge.	No significant fault.	-	-	-	-
Fast transients	6.4.4	Voltage and current circuits: 4 kV; Auxiliary circuits: 2 kV.	No significant fault.	6.0	4.0	2.0	1.0
Voltage dips	6.4.5	Test a: 30 %, 0.5 cycles Test b: 60 %, 1 cycle Test c: 60 %, 25/30 cycles ⁽³⁾	No significant fault.	-	-	-	-
Voltage interruptions	6.4.5	0 %, 250/300 cycles ⁽³⁾	No significant fault.	-	-	-	-

Radiated, RF, electromagnetic fields	6.4.6	f = 80 to 6000 MHz, 30 V/m, amplitude modulated, without current.	No significant fault.	-	-	-	-
Surges on AC mains power lines	6.4.7	Voltage circuits: 2 kV line to line, 4 kV line to earth; Auxiliary circuits: 1 kV line to line, 2 kV line to earth.	No significant fault.	-	-	-	-
Damped oscillatory waves immunity test ⁽¹⁾	6.4.8	Voltage circuits: Common mode 2.5 kV, differential mode 1.0 kV.	No significant fault. The function of the meter shall not be perturbed.	3.0	2.0	2.0	1.0
Short-time overcurrent	6.4.9	Direct connected meters: $30 \cdot I_{max}$; Transformer-operated meters: $20 \cdot I_{max}$.	No significant fault. No damage shall occur.	Transformer-operated			
				1.0	0.5	0.05	0.05
				Direct connected			
1.5	1.5	0.05	0.05				
Impulse voltage	6.4.10	3 kV (≤ 100 V); 6 kV (≤ 150 V); 10 kV (≤ 300 V); 12 kV (≤ 600 V).	No significant fault. No damage to the meter.	-	-	-	-
Earth fault ⁽²⁾	6.4.11	Earth fault in one phase	No significant fault. No damage and shall operate correctly.	1.0	0.7	0.3	0.1
Operation of ancillary devices	6.4.12	Ancillary devices operated with $I = I_{min}$ and I_{max}	No significant fault.	1/3 base mpe			1/2 base mpe
Vibration	6.4.13.1	Vibration in three mutually perpendicular axes	No significant fault. Function of the meter shall not be impaired.	1/3 base mpe			1/2 base mpe
Shock	6.4.13.2	Pulse shape: Half-sine, Peak acceleration: 300 ms^{-2} , Pulse duration: 18 ms	No significant fault.	1/3 base mpe			1/2 base mpe
Protection against solar radiation	6.4.14	$0.76 \text{ W} \cdot \text{m}^2 \cdot \text{nm}^{-1}$ at 340 nm, with cycling rig for 66 days	No alteration in appearance or impairment in functionality, metrological properties and sealing.	-	-	-	-
Protection against ingress of dust	6.4.15	IP 5x, category 2 enclosure	No interference with correct operation or impairment of safety, including tracking along creepage distances.	-	-	-	-
Dry heat	6.4.16.1	One standard temperature higher than upper specified temperature limit, 2 h	No significant fault.	1/3 base mpe			1/2 base mpe

Cold	6.4.16.2	One standard temperature lower than lower specified temperature limit, 2 h	No significant fault.	1/3 base mpe			1/2 base mpe
Damp Heat	6.4.16.3, 6.4.16.4	H1: 30 °C, 85 %; H2: Cyclic 25 °C, 95 % to 40 °C, 93 %; H3: Cyclic 25 °C, 95 % to 55 °C, 93 %.	No significant fault. No evidence of any mechanical damage or corrosion.	±0.2	±0.1	±0.05	±0.05
Water	6.4.16.5	H3 only, 0.07 L/min (per nozzle), 0 ° and 180 °, 10 min	No significant fault. No evidence of any mechanical damage or corrosion.	-	-	-	-
Durability	6.4.17	High current and/or temperature for a sustained period of time	No significant fault.	1/3 base mpe			1/2 base mpe
<p>(1) Only for transformer operated meters.</p> <p>(2) Only for three-phase four-wire transformer-operated meters intended for use in networks equipped with earth fault neutralizers</p> <p>(3) These values are for 50 Hz / 60 Hz respectively</p>							

If no significant fault occurs during the appropriate tests described in Part 2 of this Recommendation, the meter is presumed to comply with the requirements of this sub-clause.

3.4 Requirements for interval and multi-tariff meters

Interval meters shall be able to measure and store data relevant for billing. ~~The minimum storage period for this data shall be determined by national authorities.~~ Manufacturers shall specify the interval data storage capabilities of the meters (e.g.: 200 days for 30-minute interval data). The specified storage capabilities shall be listed on the certificates of approval. For interval meters, the summation of interval data shall equate to the cumulative register value over the same period.

The internal clocks of interval and multi-tariff meters shall meet the requirements of IEC 62054-21.

For multi-tariff meters, only a single register (in addition to the cumulative register) shall be active at any time. The summation of values recorded in each multi-tariff register shall equate to the value recorded in the cumulative register.

3.5 Meter markings

~~National authorities shall determine what information must be marked on every meter. It is recommended that the following be considered:~~

The following information must be marked on every meter:

- a) Manufacturer – name or mark
- b) Meter model
- c) U_{nom}
- d) I_{max}
- e) I_{tr}
- f) I_{min}
- g) Approval mark(s) – space for pattern approval number
- h) Serial number
- i) Number of phases
- j) Number of wires
- k) Register multiplier (if other than unity)

- l) Meter constant(s)
- m) Year of manufacture
- n) Accuracy class
- ~~Directionality of energy flow if the meter is bidirectional or unidirectional. No marking is required if the meter is capable only of positive direction energy flow.~~
- ~~Meter type~~
- ~~Temperature range~~
- ~~Humidity and water protection information~~
- ~~Impulse voltage protection information~~
- o) f_{nom}
- p) The connection mode(s) for which the meter is specified
- ~~Connection terminals uniquely identified to distinguish between terminals.~~

The markings shall be indelible, distinct and legible from outside the meter. The markings of meters intended for outdoor locations shall withstand solar radiation. Multiple values of U_{nom} and f_{nom} may be marked if so specified by the manufacturer.

Markings a) to p) shall be visible when the meter is installed. If there is limited space available on the meter exterior that is visible when installed, information in points a), b), g) and h) are mandatory. In this case, other mandatory markings must be available either via the meter display, or marked elsewhere on the meter exterior.

If the serial number is affixed to dismountable parts, the serial number shall also be provided in a position where it is not readily disassociated from parts determining the metrological characteristics.

Symbols or their equivalent may be used where appropriate. See e.g. IEC 62053-52, *Electricity metering equipment (AC) – Particular requirements – Part 52: Symbols*, or other designations accepted by local jurisdictions.

3.6 Protection of metrological properties

3.6.1 General

3.6.1.1 Electricity meters shall be provided with the means to protect their metrological properties. National authorities shall determine levels of authorized access for software protection (3.6.3), parameter protection (3.6.4) and checking facility event record (3.6.9). [Utility Meter Verifiers \(UMV\) are appointed to verify electricity meters. Levels of authorised access may be specified for a UMV under their conditions of appointment.](#)

3.6.1.2 All means to protect the metrological properties of an electricity meter intended for outdoor locations shall withstand solar radiation.

3.6.2 Software identification

Legally relevant software of an electricity meter shall be clearly identified with the software version or another token. The identification may consist of more than one part but at least one part shall be dedicated to the legal purpose.

The identification shall be inextricably linked to the software itself and shall be presented on command or displayed during operation.

As an exception, an imprint of the software identification on the electricity meter shall be an acceptable solution if it satisfies the three following conditions:

- 1) The user interface does not have any control capability to activate the indication of the software identification on the display, or the display does not technically allow the identification of the software to be shown (analog indicating device or electromechanical counter).
- 2) The electricity meter does not have an interface to communicate the software identification.
- 3) After production of the electricity meter a change of the software is not possible, or only possible if the hardware or a hardware component is also changed.

The manufacturer of the hardware or the concerned hardware component is responsible for ensuring that the software identification is correctly marked on the concerned meter.

The software identification and the means of identification shall be stated in the type approval certificate.

3.6.3 Software protection

3.6.3.1 Prevention of misuse

An electricity meter shall be constructed in such a way that possibilities for unintentional, accidental, or intentional misuse are minimal.

3.6.3.2 Fraud protection

3.6.3.2.1 The legally relevant software shall be secured against unauthorized modification, loading, or changes by swapping the memory device. A secure means, such as mechanical or electronic sealing, is required to secure electricity meters having an option to load software/parameters.

3.6.3.2.2 Only clearly documented functions (see 4.1) are allowed to be activated by the user interface, which shall be realized in such a way that it does not facilitate fraudulent use.

3.6.3.2.3 Software protection comprises appropriate sealing by mechanical, electronic and/or cryptographic means, making an unauthorized intervention impossible or evident.

Examples:

- 1) The software of a measuring instrument is constructed such that there is no way to modify the parameters and legally relevant configuration but via a switch protected menu. This switch is mechanically sealed in the inactive position, making modification of the parameters and of the legally relevant configuration impossible. To modify the parameters and configuration, the switch has to be switched, inevitably breaking the seal by doing so.
- 2) The software of a measuring instrument is constructed such that there is no way to access the parameters and legally relevant configuration except by authorized persons. If a person wants to enter the parameter menu item ~~he~~ the person has to insert ~~his~~ their smart card containing a PIN as part of a cryptographic certificate. The software of the instrument is able to verify the authenticity of the PIN by the certificate and allows the parameter menu item to be entered. The access is recorded in an audit trail including the identity of the person (or at least of the smart card used).

3.6.4 Parameter protection

3.6.4.1 Parameters that fix the legally relevant characteristics of the electricity meter shall be secured against unauthorized modification. If necessary for the purpose of verification, the current parameter settings shall be able to be displayed.

Device-specific parameters may be adjustable or selectable only in a special operational mode of the electricity meter. They may be classified as those that should be secured (unalterable) and those that may be accessed (settable parameters) by an authorized person, e.g. the instrument owner, repairer.

Type-specific parameters have identical values for all specimens of a type. They are fixed at type approval of the instrument.

Note 1: A simple password is not a technically acceptable solution for protecting parameters.

Note 2: Authorized persons may be allowed to access a limited set of device-specific parameters. Such a set of device specific parameters and its access limitations/rules should be clearly documented.

3.6.4.2 Zeroing the register that stores the total energy metered shall be considered as a modification of a device specific parameter. Therefore all relevant requirements applicable to device specific parameters are applicable to the zeroing operation.

3.6.4.3 When modifying a device-specific parameter, the meter shall stop registering energy.

3.6.4.4 National regulations may prescribe that certain device-specific parameters are to be available to the user. In such a case, the measuring instrument shall be fitted with a facility to automatically and non-erasably record any adjustment of the device-specific parameter, e.g. an audit trail. The instrument shall be capable of presenting the recorded data.

The traceability means and records are part of the legally relevant software and should be protected as such. The software employed for displaying the audit trail belongs to the fixed legally relevant software.

Note: An event counter is not a technically acceptable solution.

3.6.5 Separation of electronic devices and sub-assemblies

Metrologically critical parts of an electricity meter – whether software or hardware parts – shall not be inadmissibly influenced by other parts of the meter.

3.6.5.1 Sub-assemblies or electronic devices of an electricity meter that perform legally relevant functions shall be identified, clearly defined, and documented. They form the legally relevant part of the measuring system. If the sub-assemblies that perform legally relevant functions are not identified, all sub-assemblies shall be considered to perform legally relevant functions.

Example:

- 1) An electricity meter is equipped with an optical interface for connecting an electronic device to read out measurement values. The meter stores all the relevant quantities and keeps the values available for being read out for a sufficient time span. In this system only the electricity meter is the legally relevant device. Other legally non-relevant devices may exist and may be connected to the interface of the instrument provided requirement 3.6.5.2 is fulfilled. Securing of the data transmission itself (see 3.6.7) is not required.

3.6.5.2 During type testing, it shall be demonstrated that the relevant functions and data of sub-assemblies and electronic devices cannot be inadmissibly influenced by commands received via the interface.

This implies that there is an unambiguous assignment of each command to all initiated functions or data changes in the sub-assembly or electronic device.

Note: If “legally relevant” sub-assemblies or electronic devices interact with other “legally relevant” sub-assemblies or electronic devices, refer to 3.6.7.

Examples:

- 1) The software of the electricity meter (see example of 3.6.5.1 above) is able to receive commands for selecting the quantities required. It combines the measurement value with additional information – e.g. time stamp, unit – and sends this data set back to the requesting device. The software only accepts commands for the selection of valid allowed quantities and discards any other command, sending back only an error message. There may be securing means for the contents of the data set but they are not required, as the transmitted data set is not subject to legal control.
- 2) Inside the housing that can be sealed there is a switch that defines the operating mode of the electricity meter: one switch setting indicates the verified mode and the other the non-verified mode (securing means other than a mechanical seal are possible; see examples in 3.6.3.2.3. When interpreting received commands the software checks the position of the switch: in the non-verified mode the command set that the software accepts is extended compared to the mode described above; e.g. it may be possible to adjust the calibration factor by a command that is discarded in the verified mode.

3.6.6 Separation of software parts

3.6.6.1 All software modules (programs, subroutines, objects, etc.) that perform legally relevant functions or that contain legally relevant data domains form the legally relevant software part of an electricity meter; it shall be made identifiable as described in 3.6.2. If the software modules that perform legally relevant functions are not identified, the whole software shall be considered as legally relevant.

3.6.6.2 If the legally relevant software part communicates with other software parts, a software interface shall be defined. All communication shall be performed exclusively via this interface. The legally relevant software part and the interface shall be clearly documented. All legally relevant functions and data domains of the software shall be described to enable a type approval authority to decide on correct software separation.

3.6.6.3 The data domain forming the software interface including the code that exports from the legally relevant part to the interface data domain and the code that imports from the interface to the legally relevant part shall be clearly defined and documented. The declared software interface shall not be circumvented.

3.6.6.4 There shall be an unambiguous assignment of each command to all initiated functions or data changes in the legally relevant part of the software. Commands that communicate through the software interface shall be declared and documented. Only documented commands are allowed to be activated through the software interface. The manufacturer shall state the completeness of the documentation of commands.

3.6.7 Storage of data, transmission via communication systems

3.6.7.1 General

If measurement values are used at another place than the place of measurement or at a later time than the time of measurement they possibly have to leave the meter (electronic device, sub-assembly) and be stored or transmitted in an insecure environment before they are used for legal purposes. In this case the following requirements apply:

3.6.7.1.1 The measurement value stored or transmitted shall be accompanied by all relevant information necessary for future legally relevant use.

3.6.7.1.2 The data shall be protected by software means to guarantee the authenticity, integrity and, if necessary correctness of the information concerning the time of measurement. The software that displays or further processes the measurement values and accompanying data shall check the time of measurement, authenticity, and integrity of the data after having read them from the insecure storage or after having received them from an insecure transmission channel. If an irregularity is detected, the data shall be discarded or marked unusable.

Confidential keys employed for protecting data shall be kept secret and secured in the electricity meter. Means shall be provided whereby these keys can only be input or read if a seal is broken.

3.6.7.1.3 Software modules that prepare data for storing or sending, or that check data after reading or receiving belong to the legally relevant software part.

3.6.7.2 Automatic storing

3.6.7.2.1 When data storage is required, measurement data must be stored automatically when the measurement is concluded, i.e. when the final value has been generated. When the final value is from a calculation, all data that are necessary for the calculation must be automatically stored with the final value.

3.6.7.2.2 The storage device must have sufficient permanency to ensure that the data are not corrupted under normal storage conditions. There shall be sufficient memory storage for any particular application.

3.6.7.2.3 Stored data may be deleted if either

- the transaction is settled, or
- these data are printed by a printing device subject to legal control.

Note: This shall not apply to the cumulative register and audit trail.

3.6.7.2.4 After the requirements in 3.6.7.2.3 are fulfilled and when the storage is full, it is permitted to delete memorized data when both of the following conditions are met:

- data are deleted in the same order as the recording order and the rules established for the particular application are respected;
- deletion is carried out either automatically or after a special manual operation that may require specific access rights.

3.6.7.3 Data transmission

3.6.7.3.1 The measurement shall not be inadmissibly influenced by a transmission delay.

3.6.7.3.2 If network services become unavailable, no legally relevant measurement data shall be lost.

3.6.7.4 Time stamp

The time stamp shall be read from the clock of the device. Setting the clock is considered as being legally relevant. Appropriate protection means shall be taken according to 3.6.4.

Internal clocks may be enhanced by specific means (e.g. software means) to reduce their uncertainty when the time of measurement is necessary for a specific field (e.g. multi-tariff meter, interval meter).

3.6.8 Maintenance and re-configuration

Updating the legally relevant software of an electricity meter in the field should be considered as

- a modification of the electricity meter, when exchanging the software with another approved version, or
- a repair of the electricity meter, when re-installing the same version.

An electricity meter which has been modified or repaired while in service **may** requires **initial or subsequent verification, dependant on national regulations.**

National authorities may prescribe that the software update mechanism is disabled by means of a sealable setting (physical switch, secured parameter) where software updates for instruments in use are not allowed. In this case it must not be possible to update legally relevant software without breaking the seal.

Software which is not necessary for the correct functioning of the electricity meter does not require verification after being updated.

3.6.8.1 Only versions of legally relevant software that conform to the approved type are allowed for use. This issue concerns verification in the field.

3.6.8.2 Verified update

The software to be updated can be loaded locally, i.e. directly on the measuring device or remotely via a network. Loading and installation may be two different steps or combined into one, depending on the needs of the technical solution. A person should be on the installation site of the electricity meter to check the effectiveness of the update. After the update of the legally relevant software of an electricity meter (exchange with another approved version or re-installation) the electricity meter is not allowed to be employed for legal purposes before a verification of the instrument has been performed and the securing means have been renewed.

3.6.8.3 Traced update

The software is implemented in the instrument according to the requirements for traced update (3.6.8.3.1 to 3.6.8.3.7). Traced update is the procedure of changing software in a verified instrument or device after which the subsequent verification by a responsible person on site is not necessary. The software to be updated can be loaded locally, i.e. directly on the measuring device or remotely via a network. The software update is recorded in an audit trail. The procedure of a traced update comprises several steps: loading, integrity checking, checking of the origin (authentication), installation, logging and activation.

3.6.8.3.1 Traced update of software shall be automatic. On completion of the update procedure the software protection environment shall be at the same level as required by the type approval.

3.6.8.3.2 The target electricity meter (electronic device, sub-assembly) shall have fixed legally relevant software that cannot be updated and that contains all of the checking functions necessary for fulfilling traced update requirements.

3.6.8.3.3 Technical means shall be employed to guarantee the authenticity of the loaded software, i.e. that it originates from the owner of the type approval certificate. If the loaded software fails the authenticity check, the instrument shall discard it and use the previous version of the software or switch to an inoperable mode.

3.6.8.3.4 Technical means shall be employed to ensure the integrity of the loaded software, i.e. that it has not been inadmissibly changed before loading. This can be accomplished by adding a checksum or hash code of the loaded software and verifying it during the loading procedure. If the loaded software fails this test, the instrument shall discard it and use the previous version of the software or switch to an inoperable mode. In this mode, the measuring functions shall be inhibited. It shall only be possible to resume the download procedure, without omitting any steps in the process for traced update.

3.6.8.3.5 Appropriate technical means, e.g. an audit trail, shall be employed to ensure that traced updates of legally relevant software are adequately traceable within the instrument for subsequent verification and surveillance or inspection.

The audit trail shall contain at minimum the following information: success / failure of the update procedure, software identification of the installed version, software identification of the previous installed version, time stamp of the event, identification of the downloading party. An entry shall be generated for each update attempt regardless of the success.

The storage device that supports the traced update shall have sufficient capacity to ensure the traceability of traced updates of legally relevant software between at least two successive verifications in the field/inspection. After having reached the limit of the storage for the audit trail, it shall be ensured by technical means that further downloads are impossible without breaking a seal.

Note: This requirement enables inspection authorities, which are responsible for the metrological surveillance of legally controlled instruments, to back-trace traced updates of legally relevant software over an adequate period of time (depending on national legislation).

3.6.8.3.6 It is assumed that the manufacturer of the electricity meter keeps his customer well informed about updates of the software, especially the legally relevant part, and that the customer will not refuse updates. Furthermore it is assumed that manufacturer and customer, user, or owner of the instrument will agree on an appropriate procedure of performing a download depending on the use and location of the instrument. Depending on the needs and on national legal legislation it may be necessary for the user or owner of the measuring instrument to have to give his consent to a download.

3.6.8.3.7 If the requirements in 3.6.8.3.1 through 3.6.8.3.6 cannot be fulfilled, it is still possible to update the legally non-relevant software part. In this case the following requirements shall be met:

- there is a distinct separation between the legally relevant and non-relevant software;
- the whole legally relevant software part cannot be updated without breaking a seal;
- it is stated in the type approval certificate that updating the legally non-relevant part is acceptable.

3.6.9 Checking facility event record

If the meter is equipped with a checking facility, the event record of the facility shall have room for at least 100 events (~~or an alternative number determined by the national authority~~) and shall be of a first-in-first-out type. The event record may not be changed or zeroed without breaking a seal and/or without authorized access, for example by means of a code (password) or of a special device (hard key, etc.).

3.7 Suitability for use

3.7.1 Readability of result

The meter shall have one (or more) indicating device(s) which is (are) capable of presenting or displaying the numerical value of each legal unit of measure for which the meter is approved. The indicating device shall be easy to read and the characters of measurement results shall as minimum be 4 mm high. Any decimal fractions shall be clearly indicated; for mechanical registers, any decimal fraction drum shall be marked differently.

The indicating device shall not be significantly affected by exposure to normal operating conditions over the maximum duration of the meter lifetime.

The indicating device shall be able to display all data relevant for billing purposes. In the case of multiple values presented by a single indicating device it shall be possible to display the content of all relevant memories. For automatic sequencing displays, each display of register for billing purposes shall be retained for a minimum of 5 s.

For multi-tariff meters, the register which reflects the active tariff shall be indicated. It shall be possible to read each tariff register locally and each register shall be clearly identified.

Electronic registers shall be non-volatile so that they retain stored values upon loss of power. Stored values shall not be overwritten and shall be capable of being retrieved upon restoration of power. The register shall be capable of storing and displaying an amount of energy that corresponds to the meter running at $P = U_{\text{nom}} \cdot I_{\text{max}} \cdot n$ for at least 4000 h, where n is the number of phases. This capability for storage and display applies to all registers relevant for billing including positive and negative flow registers for bi-directional meters and tariff registers for multi-tariff meters.

Note: — ~~The National Authority may change the minimum time required for register rollover.~~

In the case of electronic registers, the minimum retention time for results is one year for a disconnected meter. Electronic indicating devices shall be provided with a display test that switches all the display segments on then off for the purpose of determining whether all display segments are working.

3.7.2 Testability

The meter shall be equipped with a test output for efficient testing, such as a rotor with a mark or a test pulse output. If the design of the test output is such that the pulse rate does not correspond to the measured power in every given relevant time interval, the manufacturer shall declare the necessary number of pulses to ensure a standard deviation of measurement less than 0.1 base mpe, at I_{max} , I_{tr} and I_{min} .

The relation between the measured energy given by the test output and the measured energy given by the indicating device shall comply with the marking on the name-plate.

The wavelength of the radiated signals for emitting systems shall be between 550 nm and 1 000 nm. The output device in the meter shall generate a signal with a radiation strength E_T over a defined reference surface (optically active area) at a distance of $10 \text{ mm} \pm 1 \text{ mm}$ from the surface of the meter, with the following limiting values:

ON-condition: $50 \mu\text{W}/\text{cm}^2 \leq E_T \leq 7500 \mu\text{W}/\text{cm}^2$

OFF-condition: $E_T \leq 2 \mu\text{W}/\text{cm}^2$

3.8 Durability

~~The meter shall be designed to maintain an adequate stability of its metrological characteristics over a period of time specified by the manufacturer, provided that it is properly installed, maintained and used according to the manufacturer's instructions when in the environmental conditions for which it is intended. The manufacturer shall provide evidence to support the durability claim.~~

~~The meter shall be designed to reduce as far as possible the effect of a defect that would lead to an inaccurate measurement result.~~

~~The meter shall be designed and manufactured such that either~~

- ~~a) significant durability errors do not occur, or~~
- ~~b) significant durability errors are detected and acted upon by means of a durability protection.~~

3.9 Presumption of compliance

The type of a meter is presumed to comply with the provisions in Section 3 if it passes the examination and tests specified in Part 2 of this Recommendation.

Part 2 Metrological controls and performance tests

4 Type approval

4.1 Documentation

The documentation submitted with the application for type approval shall include:

- identification of the type, including
 - name or trademark and type designation,
 - version(s) of hardware and software,
 - drawing of name plate;
- metrological characteristics of the meter, including
 - a description of the principle(s) of measurement,
 - metrological specifications such as accuracy class and rated operating conditions (section 3.1),
 - any steps which should be performed prior to testing the meter;
- the technical specification for the meter, including
 - a block diagram with a functional description of the components and devices,
 - drawings, diagrams and general software information, explaining the construction and operation, including interlocks,
 - description and position of seals or other means of protection,
 - ~~—documentation related to durability characteristics,~~
 - any document or other evidence that the design and construction of the meter complies with the requirements of this Recommendation,
 - specified clock frequencies,
 - energy consumption of the meter;
- user manual;
- installation manual;
- a description of the checking facility for significant faults, if applicable;

In addition, software documentation shall include

- a description of the legally relevant software and how the requirements are met:
 - list of software modules that belong to the legally relevant part including a declaration that all legally relevant functions are included in the description;
 - description of the software interfaces of the legally relevant software part and of the commands and data flows via this interface including a statement of completeness;
 - description of the generation of the software identification;
 - list of parameters to be protected and description of protection means;
- a description of security means of the operating system (password, etc. if applicable);
- a description of the (software) sealing method(s);

- an overview of the system hardware, e.g. topology block diagram, type of computer(s), type of network, etc.
- where a hardware component is deemed legally relevant or where it performs legally relevant functions, this should also be identified;
- a description of the accuracy of the algorithms (e.g. filtering of A/D conversion results, price calculation, rounding algorithms, etc.);
- a description of the user interface, menus and dialogues;
- the software identification and instructions for obtaining it from an instrument in use;
- list of commands of each hardware interface of the measuring instrument / electronic device / sub-assembly including a statement of completeness;
- ~~• list of durability errors that are detected by the software and if necessary for understanding, a description of the detecting algorithms;~~
- a description of data sets stored or transmitted;
- if fault detection is realized in the software, a list of faults that are detected and a description of the detecting algorithm;
- the operating manual.

Furthermore, if the type approval is to be based on existing type test documentation, the application for type approval shall be accompanied by type test documents or other evidence that supports the assertion that the design and characteristics of the measuring instrument comply with the requirements of this Recommendation.

4.2 Type definition

Meters produced by the same manufacturer may form a type, provided they have similar metrological properties resulting from the use of the same uniform construction of parts/modules that determine the metrological properties.

A type may have several current ranges and several values of the nominal voltage and frequency, and include several connection modes and several ancillary devices.

Note: The same uniform construction normally means the same construction of the measuring elements, the same construction of metering software, the same construction of the register and indicating device, the same temperature compensation mechanism, the same construction of case, terminal block, and mechanical interface.

4.2.1 Type test sampling

The manufacturer shall provide at least as many specimens of the meter as are required by the national authority. The type test shall be made on one or more specimens of the meter, selected by the type test body, to establish its specific characteristics and to prove its conformity with the requirements of this Recommendation. In the case of modifications to the meter made after or during the type test and affecting only part of the meter, the issuing body may deem it sufficient to perform limited tests on the characteristics that may be affected by the modifications.

4.3 Validation procedure

The validation procedure consists of a combination of analysis methods and tests as shown in

Table 6. The abbreviations used are described in Table 7.

Table 6 Validation procedures for specified requirements

Requirement		Validation procedure
3.6.2	Software identification	AD + VFTSw
3.6.3.1	Prevention misuse	AD + VFTSw
3.6.3.2	Fraud protection	AD + VFTSw
3.6.4	Parameter protection	AD + VFTSw
3.6.5	Separation of electronic devices and sub-assemblies	AD
3.6.6	Separation of software parts	AD
3.6.7	Storage of data, transmission via communication systems	AD + VFTSw
3.6.7.1.2	Data protection with respect to time of measurement	AD + VFTSw
3.6.7.2	Automatic storing	AD + VFTSw
3.6.7.3.1	Transmission delay	AD + VFTSw
3.6.7.3.2	Transmission interruption	AD + VFTSw
3.6.7.4	Time stamp	AD + VFTSw
3.6.8	Maintenance and re-configuration	AD

Table 7 Validation procedure abbreviations used in

Table 6

Abbreviation	Description	OIML D 31:2008 Clause
AD	Analysis of the documentation and validation of the design	6.3.2.1
VFTSw	Validation by functional testing of software functions	6.3.2.3

5 Test program

The initial intrinsic error shall be determined as the first test on the meter, as described in 6.2.1.

At the beginning of any series of tests, the meter shall be allowed to stabilize with voltage circuits energized for a period of time specified by the manufacturer.

The order of the test points for initial intrinsic error shall be from lowest current to highest current and then from highest current to lowest current. For each test point, the resulting error shall be the mean of these measurements. For I_{\max} , the maximum measurement time shall be 10 min including stabilizing time.

The determination of the intrinsic error (at reference conditions) shall always be carried out before tests of influence quantities and before disturbance tests that relate to a limit of error shift requirement or to a significant fault condition for error.

Otherwise the order of tests is not prescribed in this Recommendation.

Test (pulse) outputs may be used for tests of accuracy requirements. A test must then be made to ensure that the relation between the basic energy register and the used test output complies with the manufacturer's specification.

If a meter is specified with alternate connection modes, such as one-phase connections for poly-phase meters, the tests for base maximum permissible error in accordance with 3.3.3 shall be made for all specified connection modes.

~~National authorities may prescribe more stringent test regimes than those described in this section.~~

6 Test procedures for type approval

6.1 Test conditions

Unless otherwise stated in the individual test instructions, all influence quantities except for the influence quantity being tested shall be held at reference conditions as given by Table 8 during type approval tests.

Table 8 Reference conditions and their tolerances

Quantity	Reference conditions	Tolerance
Voltage(s) ⁽²⁾	U_{nom}	$\pm 1 \%$
Ambient temperature	$23 \text{ }^{\circ}\text{C}^{(1)}$	$\pm 2 \text{ }^{\circ}\text{C}$
Frequency	f_{nom}	$\pm 0.3 \%$
Wave-form	Sinusoidal	$d \leq 2 \%$
Magnetic induction of external origin at reference frequency	0 T	$B \leq 0.05 \text{ mT}$
Electromagnetic RF fields 30 kHz – 6 GHz	0 V/m	$\leq 1 \text{ V/m}$
Operating position for instruments sensitive to position	Mounting as stated by manufacturer	$\pm 0.5^{\circ}$
Phase sequence for poly-phase meters	L1, L2, L3	-
Load balance	Equal current in all current circuits	$\pm 2 \%$ (current) and $\pm 2^{\circ}$ (phase angle)

- (1) Tests may be performed at other temperatures if the results are corrected to the reference temperature by applying the temperature coefficient established in the type tests, and provided an appropriate uncertainty analysis is carried out.
- (2) The requirement applies to both phase-to-phase and phase-neutral for poly-phase meters
- Note:* The reference conditions and their tolerance are given to ensure reproducibility between testing laboratories, not to determine the accuracy of the tests. The demands on short time stability during test for influence factors may be much higher than shown in this table.

Table 9 Load conditions and their tolerances in tests

Quantity	Conditions	Tolerance
Current(s)	Current range of device under test	Class A, B: $\pm 2\%$ Class C, D: $\pm 1\%$
Power factor	Power factor range of device under test	current to voltage phase difference $\pm 2^\circ$

Note: The load conditions and their tolerance are given to ensure reproducibility between testing laboratories, not to determine the accuracy of the tests. The demands on short time stability during test for influence factors may be much higher than shown in Table 9.

For most tests, the measured power will be constant if the other influence quantities are kept constant at reference conditions. However, this is not possible for some tests such as influence of voltage variation and load unbalance. Therefore, the error shift shall always be measured as the shift of the relative error and not of the absolute power.

6.2 Tests for compliance with maximum permissible errors

6.2.1 Determination of initial intrinsic error

Object of the test: To verify that the error of the meter at reference conditions is less than the relevant base mpe given in Table 2.

Test procedure: Meters that are specified as being capable of bidirectional or unidirectional energy measurement as described in 3.3.2 shall meet the relevant base mpe requirements of Table 2 for energy flow in both positive and negative directions.

Meters that are specified as capable of measuring only positive energy flow as described in 3.3.2 shall meet the relevant base mpe requirements of Table 2 for positive energy flow. These meters shall also be subjected to reversed energy flow, in response to which the meter shall not register energy in the primary register or emit more than one pulse from the test output. The test time shall be at least 1 min, or the time that the test output would register 10 pulses in the positive energy flow direction, or the time that the primary register would register 2 units of the least significant digit in the positive energy flow direction, whichever is longest.

For reverse running detent designs that are prone to be affected by heating, the test time shall be extended to 10 min at I_{\max} .

Mandatory test points: Mandatory test points are specified in Table 10 for positive, negative and reverse flow tests. ~~National authorities shall select two mandatory test points as specified in Table 10.~~

~~Note: For the calculation of the combined maximum error as defined in Annex B(B.2.1 or B.2.2) it may be required by national or regional authorities to implement some additional test points to cover the power factor range of at least of 0.5 inductive to 0.8 capacitive over the current range of at least I_{\min} to I_{\max} .~~

Table 10 Mandatory test points for the determination of initial intrinsic error test

Current	Power factor	Test point mandatory for:		
		Positive flow	Negative flow	Reverse flow
I_{\min}	Unity	Yes	No	Yes
I_{tr}	Unity	Yes	Yes	No
	Most inductive ⁽¹⁾	Yes	Yes	No
	Most capacitive ⁽¹⁾	Yes	Yes	No
A testpoint within range I_{tr} to I_{\max} selected by national authority $10 I_{tr}$	Unity	Yes	No	No
	Most inductive ⁽¹⁾	Yes	No	No
	Most capacitive ⁽¹⁾	Yes	No	No
I_{\max}	Unity	Yes	Yes	Yes
	Most inductive ⁽¹⁾	Yes	Yes	No
	Most capacitive ⁽¹⁾	Yes	Yes	No

⁽¹⁾ Most inductive or capacitive according to Table 1.

6.2.2 Self-heating

Object of the test: To verify that the meter is able to carry I_{\max} continuously as specified in Table 4.

Test procedure: The test shall be carried out as follows: the voltage circuits shall first be energized at reference voltage for at least 1 h for class A meters and at least 2 h for meters of all other classes. Then, with the meter otherwise at reference conditions, the maximum current shall be applied to the current circuits. The cable to be used for energizing the meter shall be made of copper, have a length of 1 m and a cross-section which ensures that the current density is between 3.2 A/mm² and 4 A/mm².

The error of the meter shall be monitored at unity power factor and at intervals short enough to record the curve of error variation as a function of time. The test shall be carried out for at least 1 h, and in any event until the variation of error over any 20-minute period does not exceed 10 % of the base maximum permissible error. The error shift compared to the intrinsic error shall comply with the requirements given in Table 4 at all times.

If the error shift has not levelled out (so that the variation of error over any 20-minute period does not exceed 10 % of the base maximum permissible error) by the end of the test, the meter shall either be allowed to return to its initial temperature and the entire test repeated at power factor = 0.5 inductive or, if the load can be changed in less than 30 seconds, the error of the meter shall be measured at I_{\max} and power factor = 0.5 inductive and it shall be checked that the error shift compared to the intrinsic error complies with the requirements given in Table 4.

6.2.3 Starting current

Object of the test: To verify that the meter starts and continues to operate at I_{st} as given by Table 1.

Test procedure: The meter shall be subjected to a current equal to the starting current I_{st} . If the meter is designed for the measurement of energy in both directions, then this test shall be applied with energy flowing in each direction. The effect of an intentional delay in measurement after reversal of the energy direction should be taken into account when performing the test.

The meter shall be considered to have started if the output produces pulses (or revolutions) at a rate consistent with the base maximum permissible error requirements given by Table 2.

The expected time, τ , between two pulses (period) is given by:

$$\frac{3.6 \times 10^6}{m \cdot k \cdot U_{nom} \cdot I_{st}} \text{ seconds,}$$

where:

k is the number of pulses emitted by the output device of the meter per kilowatt-hour (imp/kWh) or the number of revolutions per kilowatt-hour (rev/kWh);

m is the number of elements;

the nominal voltage U_{nom} is expressed in volts; and

the starting current I_{st} is expressed in amperes.

Steps for the test procedure:

1. Start the meter.
2. Allow $1.5 \cdot \tau$ seconds for the first pulse to occur.
3. Allow another $1.5 \cdot \tau$ seconds for the second pulse to occur.
4. Determine the effective time between the two pulses.
5. Allow the effective time (after the second pulse) for the third pulse to occur.

Mandatory test points: I_{st} at unity power factor.

6.2.4 Test of no-load condition

Object of the test: To verify the no-load performance of the meter given in 3.3.4.

Test procedure: For this test, there shall be no current in the current circuit. The test shall be performed at U_{nom} .

For meters with a test output, the output of the meter shall not produce more than one pulse. For an electromechanical meter, the rotor of the meter shall not make a complete revolution.

The minimum test period Δt shall be

$$\Delta t \geq \frac{100 \times 10^3}{b \cdot k \cdot m \cdot U_{\text{nom}} \cdot I_{\text{min}}} \text{ h,}$$

where:

b is the base maximum permissible error at I_{min} expressed as a percentage (%) and is taken as a positive value;

k is the number of pulses emitted by the output device of the meter per kilowatt-hour (imp/kWh) or the number of revolutions per kilowatt-hour (rev/kWh);

m is the number of elements;

the nominal voltage U_{nom} is expressed in volts; and

the minimum current I_{min} is expressed in amperes.

For transformer-operated meters with primary rated registers where the value of k (and possibly U_{nom}) are given as primary side values, the constant k (and U_{nom}) shall be recalculated to correspond to secondary side values (of voltage and current).

Note: As an example, the minimum test period would be 0.46 h (27.8 min) for a class B meter ($b = 1.5\%$) with the following specifications: $k = 1000$ imp/kWh, $m = 1$, $U_{\text{nom}} = 240$ V and $I_{\text{min}} = 0.6$ A.

6.2.5 Meter constants

Object of the test: To verify that the relationship between the basic energy register and the used test output(s) complies with the manufacturer's specification as required in 3.7.2. The relative difference must not be greater than one tenth of the base maximum permissible error. This test is only applicable if test (pulse) outputs are used to test accuracy requirements.

Test procedure: All registers and pulse outputs that are under legal control must be tested unless a system is in place that guarantees the identical behavior of all meter constants.

The test shall be performed by passing a quantity of energy E through the meter, where E is at least:

$$E_{\text{min}} = \frac{1000 \cdot R}{b} \text{ Wh,}$$

where:

R is the apparent resolution of the basic energy register⁽¹⁾ expressed in Wh; and

b is the base maximum permissible error⁽²⁾ expressed as a percentage (%).

The relative difference between the registered energy and the energy passed through the meter as given by the number of pulses from the test output shall be computed.

Allowed effect: The relative difference shall not be greater than one tenth of the base maximum permissible error.

Mandatory test points: The test shall be performed at a single arbitrary current $I \geq I_{\text{tr}}$.

Note⁽¹⁾: Any means may be used to enhance the apparent resolution R of the basic register, as long as care is taken to ensure that the results reflect the true resolution of the basic register.

Note⁽²⁾: The value of b shall be selected from Table 2 according to the chosen test point. The value of b may differ to that applicable for the no-load test.

6.3 Tests for influence quantities

6.3.1 General

The purpose of these tests is to verify the requirements of 3.3.3 due to the variation of a single influence quantity. For influence quantities listed in Table 4, it shall be verified that the error shift due to the variation

of any single influence quantity is within the corresponding limit of error shift stated in Table 4 (see also the definition of maximum permissible error shift in 2.2.20).

6.3.2 Temperature dependence

Object of the test: To verify that the temperature coefficient requirements of Table 3 are fulfilled.

Test procedure: For each test point, the error of the meter shall be determined at the reference temperature, at each of the upper and lower ambient temperature limits specified for the meter, and at a sufficient number of other temperatures forming temperature intervals of between 15 K and 23 K that span the specified temperature range.

Furthermore, for each test point and for each temperature interval given by adjacent upper or lower temperature limits including the reference temperature, the (mean) temperature coefficient, c , shall be determined as follows:

$$c = \frac{e_u - e_l}{t_u - t_l}$$

where e_u and e_l are the errors at the uppermost and the lowest temperatures respectively in the temperature interval of interest; and

t_u and t_l are the uppermost and the lowest temperatures respectively in the temperature interval of interest.

Each temperature coefficient shall be in accordance with the requirements of Table 3.

Mandatory test points: The test shall, at minimum, be performed at PF = 1 and PF = 0.5 inductive and for currents of I_{tr} , $10 I_{tr}$ and I_{max} .

Note: — For the calculation of the combined maximum error as defined in Annex B (B.2.1 or B.2.2) it may be required by national or regional authorities to implement some additional test points to cover the power factor range of at least 0.5 inductive to 0.8 capacitive over the current range of at least I_{min} to I_{max} .

6.3.3 Load balance

Object of the test: To verify that the error shift due to load balance complies with the requirements of Table 4. This test is only for poly-phase meters and for single-phase three-wire meters.

Test procedure: The error of the meter with current in one current circuit only shall be measured and compared to the intrinsic error at balanced load. During the test, reference voltages shall be applied to all voltage circuits.

Mandatory test points: The test shall be performed for all current circuits at PF = 1 and PF = 0.5 inductive, and, at minimum, for currents of $10 I_{tr}$ and I_{max} for direct connected meters, and, at minimum, at I_{max} for transformer operated meters.

Note: — For the calculation of the combined maximum error as defined in Annex B (B.2.2) it may be required by national or regional authorities to implement some additional test points to cover the power factor range of at least 0.5 inductive to 0.8 capacitive over the current range of at least I_{min} to I_{max} .

6.3.4 Voltage variation

Object of the test: To verify that the error shift due to voltage variations complies with the requirements of Table 4.

Test procedure: The error shift, compared to the intrinsic error at U_{nom} , shall be measured when the voltage is varied within the corresponding rated operating range. For poly-phase meters, the test voltage shall be balanced. If several U_{nom} values are stated, the test shall be repeated for each U_{nom} value.

Mandatory test points: The test shall, at minimum, be performed at PF = 1 and PF = 0.5 inductive, for a current of $10 I_{tr}$, and at voltages $0.9 U_{nom}$ and $1.1 U_{nom}$.

~~Note: For the calculation of the combined maximum error as defined in Annex B (B.2.1 or B.2.2) it may be required by national or regional authorities to implement some additional test points to cover the power factor range of at least of 0.5 inductive to 0.8 capacitive over the current range of at least I_{\min} to I_{\max} .~~

6.3.5 Frequency variation

- Object of the test: To verify that the error shift due to frequency variations complies with the requirements of Table 4.
- Test procedure: The error shift, compared to the intrinsic error at f_{nom} , shall be measured when the frequency is varied within the corresponding rated operating range. If several f_{nom} values are stated, the test shall be repeated with each f_{nom} value.
- Mandatory test points: The test shall, at minimum, be performed at PF = 1 and PF = 0.5 inductive, for a current of $10 I_{\text{tr}}$, and at frequencies of $0.98 f_{\text{nom}}$ and $1.02 f_{\text{nom}}$.

~~Note: For the calculation of the combined maximum error as defined in Annex B (B.2.1 or B.2.2) it may be required by national or regional authorities to implement some additional test points to cover the power factor range of at least of 0.5 inductive to 0.8 capacitive over the current range of at least I_{\min} to I_{\max} .~~

6.3.6 Harmonics in voltage and current

- Object of the test: To verify that the error shift due to harmonics complies with the requirements
- Test procedure: The error shift, compared to the intrinsic error at sinusoidal conditions, shall be measured when harmonics are added in both the voltage and the current. The test shall be performed using the quadriform and peaked waveforms specified in Table 11 and Table 12 respectively. The amplitude of a single harmonic shall not be more than $0.12 U_1/h$ for voltage and I_1/h for the current, where h is the harmonic number and U_1 and I_1 are the respective fundamentals. Plots of the current amplitude for the waveforms in Table 11 and Table 12 are shown in Figure 1 and Figure 2 respectively.
- The r.m.s. current may not exceed I_{max} , i.e. for Table 11, the fundamental current component I_1 may not exceed $0.93 I_{\text{max}}$. The peak value of the current may not exceed $1.4 I_{\text{max}}$, i.e. for Table 12, the fundamental current component I_1 (r.m.s.) may not exceed $0.568 I_{\text{max}}$.
- Harmonic amplitudes are calculated relative to the amplitude of the fundamental frequency component of the voltage or current respectively. Phase angle is calculated relative to the zero-crossing of the fundamental frequency voltage or current component respectively.
- Mandatory test points: The test shall, at minimum, be performed at $10 I_{\text{tr}}$, PF = 1, where the power factor is given for the fundamental component.

~~Note: For the calculation of the combined maximum error as defined in Annex B (B.2.2) it may be required by national or regional authorities to implement some additional test points to cover the power factor range of at least of 0.5 inductive to 0.8 capacitive over the current range of at least I_{\min} to I_{\max} .~~

Table 11 Quadriform waveform

Harmonic number	Current amplitude	Current phase angle	Voltage amplitude	Voltage phase angle
1	100 %	0°	100 %	0°
3	30 %	0°	3.8 %	180°
5	18 %	0°	2.4 %	180°
7	14 %	0°	1.7 %	180°
11	9 %	0°	1.0 %	180°
13	5 %	0°	0.8 %	180°

Table 12 Peaked waveform

Harmonic number	Current amplitude	Current phase angle	Voltage amplitude	Voltage phase angle
1	100 %	0°	100 %	0°
3	30 %	180°	3.8 %	0°
5	18 %	0°	2.4 %	180°
7	14 %	180°	1.7 %	0°
11	9 %	180°	1.0 %	0°
13	5 %	0°	0.8 %	180°

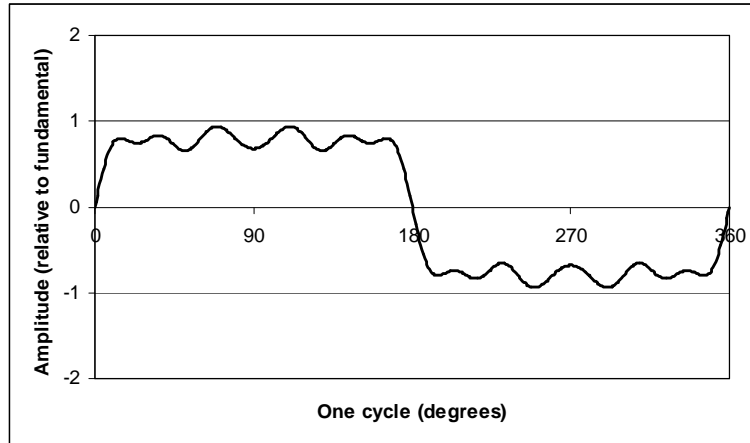

Figure 1 Current amplitude for quadriform waveform

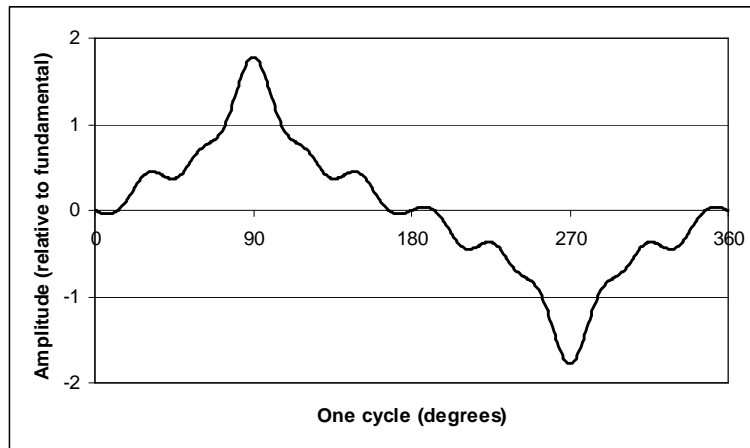

Figure 2 Current amplitude for peaked waveform.

6.3.7 Tilt

Object of the test: To verify that the error shift due to tilt complies with the requirements of Table 4. This test is only for electromechanical meters or meters of other constructions that may be influenced by the working position.

Test procedure: The error shift, compared to the intrinsic error at the operating position given by the manufacturer, shall be measured when the meter is tilted from its ideal position to an angle 3° from that position.

Mandatory test points: The test shall, at minimum, be performed at I_{tr} , PF = 1 and at two perpendicular tilting angles.

6.3.8 Severe voltage variations

Object of the test: To verify that the error shift due to severe voltage variations complies with the requirements of Table 4.

Test procedure 1: The intrinsic error shall first be measured at U_{nom} . It shall then be verified that the error shift, relative to the intrinsic error at U_{nom} complies with the requirements of Table 4 when the voltage is varied from $0.8 U_{nom}$ to $0.9 U_{nom}$ and from $1.1 U_{nom}$ to $1.15 U_{nom}$. For poly-phase meters, the test voltage shall be balanced. If several U_{nom} values are stated, the test shall be repeated for each U_{nom} value.

Mandatory test points 1: The test shall, at minimum, be performed at $10 I_{tr}$, PF = 1 and for voltages of $0.8 U_{nom}$, $0.85 U_{nom}$ and $1.15 U_{nom}$.

Test procedure 2: Further, the error shift, compared to the intrinsic error at U_{nom} , shall be measured when the voltage is varied from $0.8 U_{nom}$ down to 0.

Mandatory test points 2: The test shall, at minimum, be performed at $10 I_{tr}$, PF = 1 and for voltages of $0.7 U_{nom}$, $0.6 U_{nom}$, $0.5 U_{nom}$, $0.4 U_{nom}$, $0.3 U_{nom}$, $0.2 U_{nom}$, $0.1 U_{nom}$, and 0 V.

If the meter has a distinct shut-down voltage, then mandatory test points shall include one point above and one point below the shut-down voltage. The lower test point shall be within a 2 V range below the shut-down voltage. The upper test point shall be within a 2 V range above the turn-on voltage.

6.3.9 One or two phases interrupted

Object of the test: To verify that the error shift due to one or two phases interrupted complies with the requirements of Table 4. The test is only for poly-phase meters with three measuring elements.

Test procedure: The error shift, compared to the intrinsic error at balanced voltage and load current conditions, shall be measured when one or two of the phases are removed while keeping the load current constant. Two phases interrupted is only for those connection

modes where a missing phase means that energy can be delivered. A poly-phase meter which is powered from only one of its phases shall not have the voltage of that phase interrupted for the purposes of this test.

Mandatory test points: The test shall, at minimum, be performed at $10 I_{tr}$, with one or two of the phases removed in combinations such that each phase has been removed at least once.

6.3.10 Sub-harmonics in the AC current circuit

Object of the test: To verify that the error shift due to sub-harmonics complies with the requirements of Table 4.

Test procedure: The error shift, compared to the intrinsic error at sinusoidal conditions, shall be measured when the sinusoidal reference current is replaced by another sinusoidal signal with twice the peak value, and which is switched on and off every second period as shown by Figure 3 a) and b). (The measured power should then be the same as for the original sinusoidal signal while the r.m.s. current is 1.41 times higher). Care should be taken that no significant DC current is introduced. During the test, the peak value of the current shall not exceed $1.4 I_{max}$.

Mandatory test points: The test shall, at minimum, be performed at a reference current of $10 I_{tr}$, PF = 1.

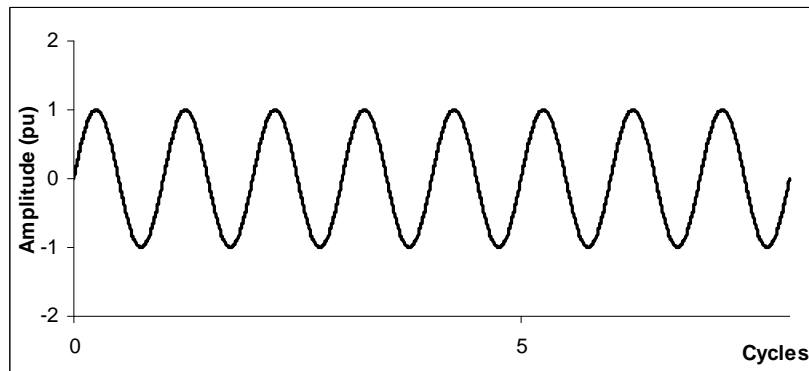

a) Continuous test current for intrinsic error

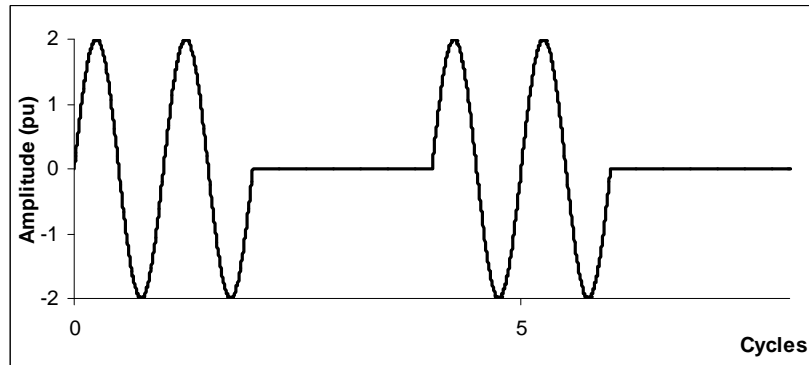

b) Sub-harmonic test current 2 cycles on, 2 cycles off

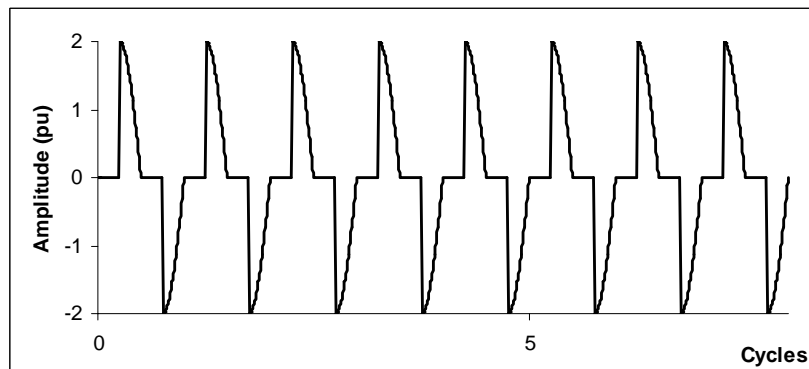

c) Harmonic test current, zero current during phase angles of 0-90° and 180-270°

Figure 3 Test currents for sub-harmonics and harmonics tests.

6.3.11 Harmonics in the AC current circuit

Object of the test: To verify that the error shift due to harmonics in the AC current circuit complies with the requirements of Table 4.

Test procedure: The error shift, compared to the intrinsic error at sinusoidal conditions, shall be measured when the sinusoidal reference current as shown in Figure 3 a) is replaced by a current with twice the original peak value where the sinusoidal waveform is set to zero during the first and third quarters of the period as shown by Figure 3 c). The measured power should then be the same as for the original sinusoidal signal while the r.m.s. current is 1.41 times higher. During the test, the peak value of the current shall not exceed $1.4 I_{max}$.

Mandatory test points: The test shall, at minimum, be performed at a reference current of $10 I_{tr}$, PF = 1. [Additional test points may be specified by national authorities.](#)

6.3.12 Reversed phase sequence (any two phases interchanged)

Object of the test: To verify that the error shift due to interchanging any two of the three phases complies with the requirements of Table 4. This test only applies to three-phase meters.

Test procedure: The error shift, compared to the intrinsic error at reference conditions, shall be measured when any two of the three phases are interchanged.

Mandatory test points: The test shall, at minimum, be performed at a reference current of $10 I_{tr}$, PF = 1 with any two of the three phases interchanged. ~~Additional test points may be specified by national authorities.~~

6.3.13 Continuous (DC) magnetic induction of external origin

Applicable standard: None.

Object of the test: To verify that the error shift due to continuous (DC) magnetic induction of external origin complies with the requirements of Table 4.

Test procedure: The error shift, compared to the intrinsic error at reference conditions, shall be measured when the meter is subjected to continuous magnetic induction with a probe in the form of a permanent magnet with a surface area of at least 2000 mm². The magnetic field along the axis of the magnet's core shall comply with details specified in Table 13 ⁽¹⁾.

~~Note ⁽⁺⁾: National authorities may select a lower magnetic induction for national requirements.~~

Table 13 Specifications of the field along axis of the magnet's core

Distance from magnet surface	Magnetic induction	Tolerance
30 mm	200 mT	± 30 mT

Mandatory test points: 6 points per meter surface. The test shall, at minimum, be performed at $10 I_{tr}$, PF = 1. The greatest error shift is to be noted as the test result.

Note: Neodymium or niobium permanent magnets are recommended for this test.

6.3.14 Magnetic field (AC, power frequency) of external origin

Applicable standard: IEC 61000-4-8.

Object of the test: To verify that the error shift due to an AC magnetic field at power frequency complies with the requirements of Table 4.

Test procedure in brief: The error shift, compared to the intrinsic error at reference conditions, shall be measured when the meter is exposed to a magnetic field at the power frequency ($f = f_{nom}$) under the most unfavourable condition of phase and direction.

Test severity: Continuous field, 400 A/m.

Mandatory test points: The test shall, at minimum, be performed at $10 I_{tr}$ and at I_{max} , PF = 1.

6.3.15 Electromagnetic fields**6.3.15.1 Radiated, radio frequency (RF), electromagnetic fields**

Applicable standard: IEC 61000-4-3.

Object of the test: To verify that the error shift due to radiated, radio frequency, electromagnetic fields complies with the requirements of Table 4. Meters such as electromechanical meters which have been constructed using only passive elements shall be assumed to be immune to radiated radiofrequency fields. Note, test condition 2 below corresponds to the disturbance test of 6.4.6.

Test procedure in brief: The error shift, compared to the intrinsic error at sinusoidal conditions, shall be measured when the meter is subjected to electromagnetic RF fields. The electromagnetic field strength shall be as specified by the severity level and the field

uniformity shall be as defined by the standard referenced. The frequency ranges to be considered are swept with the modulated signal, pausing to adjust the RF signal level or to switch oscillators and antennas as necessary. Where the frequency range is swept incrementally, the step size shall not exceed 1 % of the preceding frequency value. The test time for a 1 % frequency change shall not be less than the time to make a measurement and in any case not less than 0.5 s.

The cable length exposed to the electromagnetic field shall be 1 m.

The test shall be performed with the generating antenna facing each side of the meter. When the meter can be used in different orientations (i.e. vertical or horizontal) all sides shall be exposed to the fields during the test.

The carrier shall be modulated with 80 % AM at 1 kHz sine wave.

The meter shall be separately tested at the manufacturer’s specified clock frequencies.

Any other sensitive frequencies shall also be analyzed separately.

Note: Usually these sensitive frequencies can be expected to be the frequencies emitted by the meter.

The meter shall be tested as a table-top instrument under two test conditions, where test condition 2 corresponds to the disturbance test of 6.4.6:

Test condition 1: During the test, the meter shall be energized with reference voltage and a current equal to $10 I_{tr}$. The measurement error of the meter shall be monitored by comparison with a reference meter not exposed to the electromagnetic field or immune to the field, or by an equally suitable method. The error at each 1 % incremental interval of the carrier frequency shall be monitored and compared to the requirements of Table 4. When using a continuous frequency sweep, this can be accomplished by adjusting the ratio of the sweep time and the time of each measurement. When using incremental 1 % frequency steps, this can be accomplished by adjusting the dwell time on each frequency to fit the measurement time.

Test condition 2: During the test, the voltage and auxiliary circuits of the meter shall be energized with reference voltage. There should be no current in the current circuits and the current terminals shall be open-circuited.

Note: Test condition 2 corresponds to the disturbance test of 6.4.6, therefore the general instructions of 6.4.1 also apply.

Test severities: As defined in Table 14.

Table 14 Severity of test

For test condition	Frequency range	Field strength
Test condition 1 (with current)	80 – 6000 MHz	10 V/m
Test condition 2 (without current)	80 – 6000 MHz	30 V/m

6.3.15.2 Immunity to conducted disturbances, induced by radiofrequency fields

Applicable standard: IEC 61000-4-6.

Object of the test: To verify that the error shift due to conducted disturbances, induced by RF fields complies with the requirements of Table 4. Meters such as electromechanical meters which have been constructed using only passive elements shall be assumed to be immune to conducted disturbances induced by RF fields.

Test procedure in brief: A radiofrequency electromagnetic current to simulate the influence of electromagnetic fields shall be coupled or injected into the power ports and I/O ports of the meter using coupling/decoupling devices as defined in the standard referenced. The performance

of the test equipment consisting of an RF generator, (de)coupling devices, attenuators, etc. shall be verified.

The meter shall be tested as a table-top instrument. During the test, the meter shall be energized with reference voltage and a current equal to $10 I_{tr}$. The error at each 1 % incremental interval of the carrier frequency shall be monitored and compared to the requirements of Table 4. When using a continuous frequency sweep, this can be accomplished by adjusting the ratio of the sweep time and the time of each measurement. When using incremental 1 % frequency steps, this can be accomplished by adjusting the dwell time on each frequency to fit the measurement time.

If the meter is a poly-phase meter, the tests shall be performed at all extremities of the cable.

Test severity: RF amplitude (50 Ohm): 10 V (e.m.f.)
 Frequency range: 0.15 – 80 MHz
 Modulation: 80 % AM, 1 kHz sine wave

6.3.16 DC in the AC current circuit

Object of the test: To verify that the error shift due to DC in the AC current circuit complies with the requirements of Table 4. Electromechanical and transformer operated meters shall be assumed to be immune to DC in the AC current circuit.

Test procedure: The error shift, compared to the intrinsic error at sinusoidal conditions at $I = I_{max} / 2\sqrt{2}$, shall be measured when the current amplitude is increased to twice its value ($I = I_{max} / \sqrt{2}$) and is half-wave rectified.

Mandatory test points: The test shall be performed at PF = 1.

Note 1: The half-wave rectification and measurement can be performed as shown in Figure 4 (only the current path is shown, the voltage shall be connected as normal). The uncertainty of measurement in this method is very dependent on the (sub-period) output impedance of the current source and the current circuit impedance of the standard meter in combination with the possible impedance differences of the two current branches.

Note 2: Since the uncertainty is dependent on the absolute branch impedance difference and not the relative (if not $R_{balancing} \gg R_{source}$), the problem can generally not be remedied by introducing additional matched resistors in each branch. It can, however, be monitored by studying the DC current from the source. The DC components should not be higher than 0.5 to 1 % of the AC value. (When measuring a DC component in the order of 1 % of the AC component, the instrument should preferably be calibrated beforehand by a measurement of the test current with the test circuit diodes disconnected and short-circuited.)

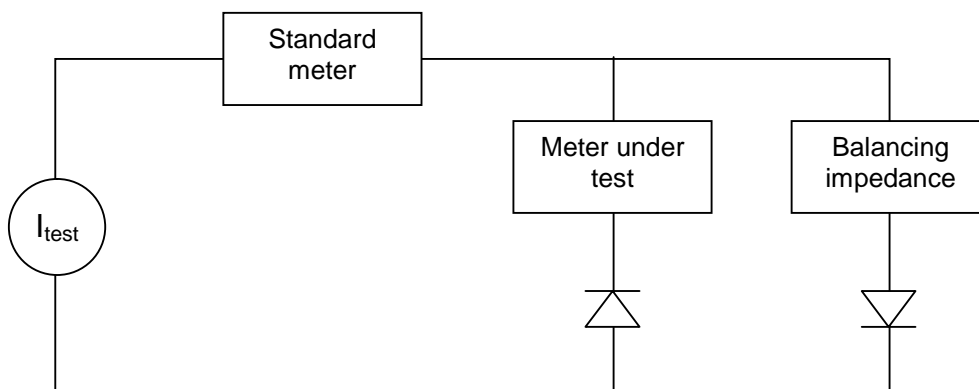

Figure 4 Proposed current test circuit for DC and even harmonic test (only one-phase current circuit shown, voltage to be connected as normal)

6.3.17 High-order harmonics

Object of the test: To verify that the error shift due to high-order harmonics complies with the requirements of Table 4. Furthermore, the function of the meter shall not be impaired.

Test procedure: The error shift, compared to the intrinsic error at sinusoidal conditions, shall be measured when asynchronous test signals, swept from $f = 15 f_{nom}$ to $40 f_{nom}$, are superimposed first on the signal to the voltage circuits and then on the signal to the current circuits. In the case of a poly-phase meter all voltage or current circuits may be tested at the same time. The signal frequency shall be swept from low frequency to high frequency and back down while the metering error is measured.

Test severity: The asynchronous signal shall have a value of $0.02 U_{nom}$ and $0.1 I_{tr}$, with a tolerance of $\pm 5\%$.

Mandatory test points: The test shall be performed at I_{tr} . One reading shall be taken per harmonic frequency.

6.4 Tests for disturbances

6.4.1 General instructions for disturbance tests

These tests are to verify that the meter fulfils the requirements for the influence of disturbances as given by Table 5. Tests are to be performed using one disturbance at a time; all other influence quantities shall be set to reference conditions unless otherwise stated in the relevant test description. No significant fault shall occur. Unless otherwise stated, each test shall include

- a) a check that any change in the registers or equivalent energy of the test output is less than the critical change value given in 3.3.6.2,
- b) an operational check to verify that the meter registers energy when subjected to current,
- c) a check for correct operation of pulse outputs and tariff change inputs, if present, and
- d) confirmation by measurement that the meter still fulfils the base maximum permissible error requirements after the disturbance test.

Temporary loss of functionality is allowed as long as the meter returns to normal functionality automatically when the disturbance is removed.

The mandatory test points for checking the base maximum permissible error are

- 1) I_{tr} , PF = 1,
- 2) $10 I_{tr}$, PF = 0.5 inductive.

6.4.2 Magnetic field (AC, power frequency) of external origin

Applicable standard: IEC 61000-4-8.

Object of the test: To verify compliance with the requirements of 3.3.6.2 and Table 5 under conditions of an AC magnetic field at power frequency of external origin.

Test procedure in brief: The meter shall be connected to the reference voltage but with no current in the current circuits. The magnetic field shall be applied along three orthogonal directions.

Allowed effects: No significant fault shall occur.

Test severity: Magnetic field strength short duration (3 s): 1000 A/m.

6.4.3 Electrostatic discharge

Applicable standard: IEC 61000-4-2.

Object of the test: To verify compliance with the requirements of 3.3.6.2 and Table 5 under conditions of direct and indirect electrostatic discharge. Meters such as electromechanical meters

which have been constructed using only passive elements shall be assumed to be immune to electrostatic discharges.

Test procedure in brief: An ESD generator shall be used with performance characteristics specified in the referenced standard. Before starting the tests, the performance of the generator shall be verified. At least 10 discharges, in the most sensitive polarity, shall be applied. For a meter not equipped with a ground terminal, the meter shall be fully discharged between discharges. Contact discharge is the preferred test method. Air discharges shall be used where contact discharge cannot be applied.

Direct application: In the contact discharge mode to be carried out on conductive surfaces, the electrode shall be in contact with the meter. In the air discharge mode on insulated surfaces, the electrode is approached to the meter and the discharge occurs by spark.

Indirect application: The discharges are applied in the contact mode to coupling planes mounted in the vicinity of the meter.

Test conditions: The test shall be done with the meter in operating condition. The voltage circuits shall be energized with U_{nom} and the current and auxiliary circuits shall be open, without any current. The meter shall be tested as table-top equipment.

Allowed effects: No significant fault shall occur.

Test severity: Contact discharge voltage ⁽¹⁾: 8 kV
Air discharge voltage ⁽²⁾: 15 kV

Note ⁽¹⁾: Contact discharges shall be applied on conductive surfaces.

Note ⁽²⁾: Air discharges shall be applied on non-conductive surfaces.

6.4.4 Fast transients

Applicable standards: IEC 61000-4-1, IEC 61000-4-4.

Object of the test: To verify compliance with the requirements of 3.3.6.2 and Table 5 under conditions where electrical bursts are superimposed on voltage and current circuits, and I/O and communication ports. Meters such as electromechanical meters which have been constructed using only passive elements shall be assumed to be immune to fast transients.

Test procedure in brief: A burst generator shall be used with the performance characteristics specified in the referenced standard. The meter shall be subjected to bursts of voltage spikes for which the repetition frequency of the impulses and peak values of the output voltage on 50 Ohm and 1000 Ohm loads are defined in the referenced standard. The characteristics of the generator shall be verified before connecting the meter. Both positive and negative polarity bursts shall be applied. The duration of the test shall not be less than 1 min for each amplitude and polarity. A capacitive coupling clamp, as defined in the standard, shall be used to couple to I/O and communication lines with a reference voltage over 40 V. The test pulses shall be applied continuously during the measurement time.

Test conditions: The meter shall be tested as table-top equipment.

The meter voltage and auxiliary circuits shall be energized with reference voltage.

The cable length between the coupling device and the meter shall be 1 m.

The test voltage shall be applied in common mode (line-to-earth) to

- a) the voltage circuits,
- b) the current circuits, if separated from the voltage circuits in normal operation,
- c) the auxiliary circuits, if separated from the voltage circuits in normal operation and with a reference voltage over 40 V.

Test severity: Test voltage on the current and voltage circuits: 4 kV.
 Test voltage on auxiliary circuits with a reference voltage over 40 V: 2 kV.

Allowed effects: The error shift, compared to the intrinsic error at reference conditions, shall be less than that given for the relevant meter class in Table 5.

Mandatory test points: $10 I_{tr}$, PF = 1.

6.4.5 Voltage dips and interruptions

Applicable standards: IEC 61000-4-11, IEC 61000-6-1, IEC 61000-6-2.

Object of the test: To verify compliance with the requirements of 3.3.6.2 and Table 5 under conditions of short time mains voltage reductions (dips and interruptions). Meters such as electromechanical meters which have been constructed using only passive elements shall be assumed to be immune to voltage dips and interruptions.

Test procedure in brief: A test generator, which is able to reduce the amplitude of the AC mains voltage over an operator-defined period of time, should be used in this test. The performance of the test generator shall be verified before connecting the meter.

The mains voltage reductions shall be repeated 10 times with an interval of at least 10 seconds.

Test conditions: Voltage circuits energized with U_{nom} .
 Without any current in the current circuits.

Test severities: Voltage dips:

Test	Test a	Test b	Test c
Reduction:	30 %	60 %	60 %
Duration:	0.5 cycles	1 cycle	25 cycles (50 Hz) 30 cycles (60 Hz)

Voltage interruption test:

Reduction:	0 %
Duration:	250 cycles (50 Hz) 300 cycles (60 Hz)

Allowed effect: No significant fault shall occur.

6.4.6 Radiated, radio frequency (RF), electromagnetic fields

Applicable standard: IEC 61000-4-3

Object of the test: To verify compliance with the requirements of 3.3.6.2 and Table 5 under conditions of radiated, radio frequency, electromagnetic fields. Meters such as electromechanical meters which have been constructed using only passive elements shall be assumed to be immune to radiated radiofrequency fields.

Test procedure: Refer to 6.3.15.1 for test procedure.

Allowed effects: No significant fault shall occur.

6.4.7 Surges on AC mains power lines

Applicable standard: IEC 61000-4-5.

Object of the test: To verify compliance with the requirements of 3.3.6.2 and Table 5 under conditions where electrical surges are superimposed on the mains voltage and, if applicable, on

I/O and communication ports. This test is not applicable for meters such as electromechanical meters which shall be assumed to be immune to surges.

Test procedure in brief: A surge generator shall be used with the performance characteristics specified in the referenced standard. The test consists of exposure to surges for which the rise time, pulse width, peak values of the output voltage/current on high/low impedance load, and minimum time interval between two successive pulses are defined in the referenced standard.

The characteristics of the generator shall be verified before connecting the meter.

Test conditions: Meter in operating condition;
 Voltage circuits energized with nominal voltage;
 Without any current in the current circuits and the current terminals shall be open;
 Cable length between surge generator and meter: 1 m;
 Tested in differential mode (line to line);
 Phase angle: pulses to be applied at 60° and 240° relative to zero crossing of AC supply.

Test severities: Voltage circuits:

- Line to line: Test voltage: 2.0 kV, generator source impedance: 2 Ω;
- Line to earth⁽¹⁾: Test voltage: 4.0 kV, generator source impedance: 2 Ω;
- Number of tests: 5 positive and 5 negative;
- Repetition rate: maximum 1/min.

Auxiliary circuits with a reference voltage over 40 V:

- Line to line: Test voltage 1.0 kV, generator source impedance 42 Ω;
- Line to earth⁽¹⁾: Test voltage 2.0 kV, generator source impedance 42 Ω;
- Number of tests: 5 positive and 5 negative;
- Repetition rate: maximum 1/min.

Note⁽¹⁾: For cases where the earth of the meter is separate to neutral.

6.4.8 Damped oscillatory waves immunity test

Applicable standard: IEC 61000-4-12.

Object of the test: To verify compliance with the requirements of 3.3.6.2 and Table 5 under conditions of damped oscillatory waves. This test is only for meters intended to be operated with voltage transformers.

Test procedure in brief: The meter is subjected to damped oscillatory voltage waveforms with a peak voltage according to the test severity stated below.

Test conditions: Meters shall be tested as table-top equipment;
 Meters shall be in operating condition;
 Voltage circuits energized with nominal voltage;
 With $I = 20 I_{tr}$ and power factor one and 0.5 inductive.

Test severities: Test voltage on voltage circuits and auxiliary circuits with an operating voltage > 40 V:

- common mode: 2.5 kV;
- differential mode: 1.0 kV;

Test frequencies:

- 100 kHz, repetition rate: 40 Hz;
- 1 MHz, repetition rate: 400 Hz;

Test duration: 60 s (15 cycles with 2 s on, 2 s off, for each frequency).

Allowed effects: During the test the function of the meter shall not be perturbed and the error shift shall be less than the limits given in Table 5.

Mandatory test points: $20 I_{tr}$, PF = 1 and 0.5 inductive.

6.4.9 Short-time overcurrent

Object of the test: To verify compliance with the requirements of 3.3.6.2 and Table 5 under conditions of a short time overcurrent.

Test procedure in brief: The meter shall be able to handle the current caused by a short-circuit within the load being metered, when that load is protected with the proper fuses or breakers.

Test current: For direct connected meters: $30 \cdot I_{max} + 0 \% - 10 \%$, for one half cycle at rated frequency or equivalent. For meters connected through current transformers: A current equivalent to $20 \cdot I_{max} + 0 \% - 10 \%$, for 0.5 s.

The test current shall be applied to one phase at the time. The test current value given is the r.m.s. value, not the peak value.

Allowed effects: No damage shall occur. With the voltage reconnected the meter shall be allowed to return to normal temperatures (about 1 h). The error shift, compared to the initial error before the test, shall then be less than the limit of error shift given by Table 5.

Mandatory test points: $10 I_{tr}$, PF = 1.

6.4.10 Impulse voltage

6.4.10.1 General

Object of the test: To verify compliance with the requirements of 3.3.6.2 and Table 5 under conditions of impulse voltage.

General test procedure: The meter and its incorporated ancillary devices, if any, shall be such that they retain adequate dielectric qualities, taking account of the atmospheric influences and different voltages to which they are subjected under normal conditions of use.

The meter shall withstand the impulse voltage test as specified below. The test shall be carried out only on complete meters.

For the purpose of this test, the term “earth” has the following meaning:

- a) when the meter case is made of metal, the “earth” is the case itself, placed on a flat, conducting surface;
- b) when the meter case or only part of it is made of insulating material, the “earth” is a conductive foil wrapped around the meter touching all accessible conductive parts and connected to the flat, conducting surface on which the meter is placed. The distances between the conductive foil and the terminals, and between the conductive foil and the holes for the conductors, shall be no more than 2 cm.

During the impulse voltage test, the circuits that are not under test shall be connected to the earth.

General test conditions: Ambient temperature: 15 °C to 25 °C;

Relative humidity: 25 % to 75 %;

Atmospheric pressure: 86 kPa to 106 kPa.

Allowed effects: After completion of the impulse voltage test, there shall be no damage to the meter and no significant fault shall occur.

6.4.10.2 Impulse voltage test procedure

Test conditions: Impulse waveform: 1.2/50 μ s impulse specified in IEC 60060-1;

Voltage rise time: ± 30 %;

Voltage fall time: ± 20 %;

Source energy: 10.0 J \pm 1.0 J;

Test voltage: in accordance with Table 15;

Test voltage tolerance: +0 –10 %.

Note: The selection of the source impedance is at the discretion of the testing laboratory.

For each test (see 6.4.10.3 and 6.4.10.4) the impulse voltage is applied ten times with one polarity and then repeated ten times with the other polarity. The minimum time between impulses shall be 30 s.

Table 15 Impulse voltage test levels

Voltage phase to earth derived from rated system voltage (V)	Rated impulse voltage (V)
$V \leq 100$	3 000
$100 < V \leq 150$	6 000
$150 < V \leq 300$	10 000
$300 < V \leq 600$	12 000
Note: The national authority may change the applicable rated impulse voltage levels.	

6.4.10.3 Impulse voltage tests for circuits and between circuits

Test procedure: The test shall be made independently on each circuit (or assembly of circuits) which is insulated from other circuits of the meter in normal use. The terminals of the circuits which are not subjected to impulse voltage shall be connected to earth.

Thus, when the voltage and current circuits of a measuring element are connected together in normal use, the test shall be made on the whole. The other end of the voltage circuit shall be connected to earth and the impulse voltage shall be applied between the terminal of the current circuit and earth. When several voltage circuits of a meter have a common point, this point shall be connected to earth and the impulse voltage successively applied between each of the free ends of the connections (or the current circuit connected to it) and earth. The other end of this current circuit shall be open.

When the voltage and current circuits of the same measuring element are separated and appropriately insulated in normal use (e.g. each circuit connected to measuring transformer), the test shall be made separately on each circuit.

During the test of a current circuit, the terminals of the other circuits shall be connected to earth and the impulse voltage shall be applied between one of the terminals of the current circuit and earth. During the test of a voltage circuit, the terminals of the other circuits and one of the terminals of the voltage circuit under test shall be connected to earth and the impulse voltage shall be applied between the other terminal of the voltage circuit and earth.

The auxiliary circuits intended to be connected either directly to the mains or to the same voltage transformers as the meter circuits, and with a reference voltage over

40 V, shall be subjected to the impulse voltage test by being tied together with a voltage circuit during tests. The other auxiliary circuits shall not be tested.

6.4.10.4 Impulse voltage test of electric circuits relative to earth

Test procedure: All the terminals of the electric circuits of the meter, including those of the auxiliary circuits with a reference voltage over 40 V, shall be connected together.

The auxiliary circuits with a reference voltage below or equal to 40 V shall be connected to earth. The impulse voltage shall be applied between all the electric circuits and earth.

Allowed effects: During this test no flashover, disruptive discharge or puncture shall occur.

6.4.11 Earth fault

Object of the test: To verify compliance with the provisions of 3.3.6.2 and Table 5 under conditions of earth fault.

This test only applies to three-phase four-wire transformer-operated meters connected to distribution networks which are equipped with earth fault neutralizers or in which the star point is isolated. In the case of an earth fault and with 10 % overvoltage, the line-to-earth voltages of the two lines which are not affected by the earth fault will rise to 1.9 times the nominal voltage.

Test procedure: The following test requirements apply:

For a test under a simulated earth fault condition in one of the three lines, all voltages are increased to 1.1 times the nominal voltages during 4 h. The neutral terminal of the meter under test is disconnected from the ground terminal of the meter test equipment (MTE) and is connected to the MTE's line terminal at which the earth fault has to be simulated (see Figure 5). In this way, the two voltage terminals of the meter under test which are not affected by the earth fault are connected to 1.9 times the nominal phase voltages.

Allowed effects: After the test, the meter shall show no damage and shall operate correctly. The change of error measured when the meter is back at nominal working temperature shall not exceed the limits given in Table 5.

Mandatory test points: $10 I_{tr}$, power factor = 1, balanced load.

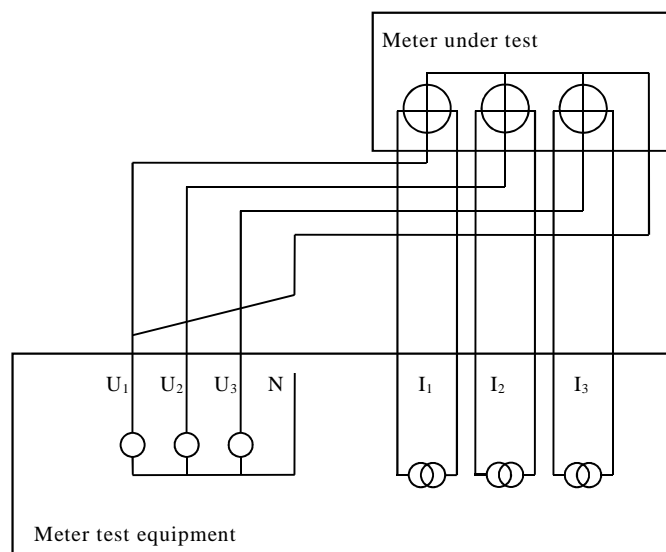

Figure 5 Set-up for earth fault test

6.4.12 Operation of ancillary devices

- Object of the test:** To verify compliance with the provisions of 3.3.6.2 and Table 5 under conditions of operation of ancillary devices. The operation of ancillary devices shall be tested to ensure that they do not affect the metrological performance of the meter.
- Test procedure:** In this test, the meter shall be operated at reference conditions and its error continuously monitored, while ancillary devices such as communication devices, relays and other I/O circuits are operated.
- Allowed effects:** The functionality of the meter shall not be impaired and the error shift due to the operation of the ancillary devices shall always be less than the error shift limit specified in Table 5.
- Mandatory test points:** I_{tr} and I_{max} at PF = 1.

6.4.13 Mechanical tests

6.4.13.1 Vibrations

Applicable standards: IEC 60068-2-47, IEC 60068-2-64.

- Object of the test:** To verify compliance with the provisions of 3.3.6.2 and Table 5 under conditions of vibrations.
- Test procedure in brief:** The meter shall, in turn, be tested in three, mutually perpendicular axes whilst mounted on a rigid fixture by its normal mounting means.
- The meter shall normally be mounted so that the gravitational force acts in the same direction as it would in normal use. Where the effect of gravitational force is not important the meter may be mounted in any position.

Test severity:

Total frequency range	10 – 150 Hz
Total r.m.s. level	$7 \text{ m}\cdot\text{s}^{-2}$
Acceleration Spectral Density (ASD) level 10 – 20 Hz	$1 \text{ m}^2\cdot\text{s}^{-3}$
Acceleration Spectral Density (ASD) level 20 – 150 Hz	–3 dB/octave
Duration per axis:	at least 2 min.

- Allowed effects:** After the test, the function of the meter shall not be impaired and the error shift, at $10 I_{tr}$, shall not exceed the limit of error shift listed in Table 5.
- Mandatory test points:** $10 I_{tr}$, PF = 1.

6.4.13.2 Shock

Applicable standard: IEC 60068-2-27.

- Object of the test:** To verify compliance with the provisions of 3.3.6.2 and Table 5 under conditions of shock.
- Test procedure in brief:** The meter is subjected to non-repetitive shocks of standard pulse shapes with specified peak acceleration and duration. During the test, the meter shall not be operational and it shall be fastened to a fixture or to the shock-testing machine.
- Test severity:** Pulse shape: half-sine;
Peak acceleration: $30 g_n$ (300 ms^{-2});

Pulse duration: 18 ms.

Allowed effects: After the test, the function of the meter shall not be impaired and the error shift, at $10 I_{tr}$, shall not exceed the limit of error shift listed in Table 5.

Mandatory test points: $10 I_{tr}$, PF = 1.

6.4.14 Protection against solar radiation

Applicable standard: ISO 4892-3.

The object of the test: To verify compliance with the requirements of 3.5, 3.6.1, 3.7.1 and 3.3.6.2 regarding protection against solar radiation. For outdoor meters only.

Test conditions: Meter in non-operating condition.

Test apparatus: Lamp type/wavelength: UVA 340;

Black panel thermometer;

Light meter;

Cycling rig with a condensation cycle to comply with the parameters in the test conditions.

Test conditions: Meter in non-operating condition

Test cycle (12 h cycle)	Lamp type	Spectral irradiance	Black panel temperature
8 h dry	UVA 340	$0.76 \text{ W} \cdot \text{m}^{-2} \cdot \text{nm}^{-1}$ at 340 nm	$60 \pm 3 \text{ }^\circ\text{C}$
4 h condensation		Light off	$50 \pm 3 \text{ }^\circ\text{C}$

Test procedure in brief: Partially mask a section of the meter for later comparison. Expose the meter to artificial radiation and weathering in accordance with ISO 4892-3 for a period of 66 days (132 cycles) and in accordance with the test conditions above.

After the test the meter shall be visually inspected and a functional test shall be performed. The appearance and, in particular, the legibility of markings and displays shall not be altered. Any means of protection of the metrological properties, such as the case and sealing, shall not be affected. The function of the meter shall not be impaired.

6.4.15 Protection against ingress of dust

Applicable standard: IEC 60529.

The object of the test: To verify compliance with the provisions of 3.3.6.2 and Table 5 regarding protection against the ingress of dust.

Test conditions: Reference conditions;

IP 5X rating;

Category 2 enclosure.

Test procedure in brief: After the test the interior of the meter shall be visually inspected and a functional test shall be performed.

Allowed effects: The talcum powder or other dust used in the test shall not have accumulated in a quantity or location such that it could interfere with the correct operation of the equipment or impair safety. No dust shall deposit where it could lead to tracking along the creepage distances. The function of the meter shall not be impaired.

6.4.16 Climatic tests**6.4.16.1 Extreme temperatures - dry heat**

Applicable standards: IEC 60068-2-2, IEC 60068-3-1.

Object of the test: To verify compliance with the provisions of 3.3.6.2 and Table 5 under conditions of dry heat.

Test procedure in brief: The test consists of exposure to the specified high temperature under “free air” conditions for 2 h (beginning from when the temperature of the meter is stable), with the meter in a non-operating state.

The change of temperature shall not exceed 1 °C/min during heating up and cooling down.

The absolute humidity of the test atmosphere shall not exceed 20 g/m³.

Test severity: The test shall be performed at a standard temperature one step higher than the upper temperature limit specified for the meter.

Possible temperatures: ~~40 °C~~ ~~55 °C~~ 70 °C 85 °C.

Allowed effects: After the test, the function of the meter shall not be impaired and the error shift shall not exceed the limit of error shift listed in Table 5.

Mandatory test points: 10 I_{tr} , PF = 1.

6.4.16.2 Extreme temperatures - cold

Applicable standards: IEC 60068-2-1, IEC 60068-3-1.

Object of the test: To verify compliance with the provisions of 3.3.6.2 and Table 5 under conditions of low temperatures.

Test procedure in brief: The test consists of exposure to the specified low temperature under “free air” conditions for 2 h (beginning from the time when the temperature of the meter is stable) with the meter in a non-operating state.

The change of temperature shall not exceed 1 °C/min during heating up and cooling down.

Test severity: The test shall be performed at a standard temperature one step lower than the lower temperature limit specified for the meter.

Possible temperatures: ~~-10 °C~~ -25 °C -40 °C -55 °C⁽¹⁾.

Allowed effects: After the test, the function of the meter shall not be impaired and the error shift shall not exceed the limit of error shift listed in Table 5.

Mandatory test points: 10 I_{tr} , PF = 1.

Note ⁽¹⁾: If specified lower temperature limit is -55 °C, then this test shall be performed at -55 °C.

6.4.16.3 Damp heat, steady-state (non-condensing), for humidity class H1

Applicable standards: IEC 60068-2-78, IEC 60068-3-4.

Object of the test: To verify compliance with the provisions in Table 4, 3.3.6.2 and Table 5 under conditions of high humidity and constant temperature. For meters that are specified for enclosed locations where the meters are not subjected to condensed water, precipitation, or ice formations (H1).

Test procedure in brief: The test consists of exposure to the specified high level temperature and the specified constant relative humidity for a certain fixed time defined by the severity level. The meter shall be handled such that no condensation of water occurs on it.

Test conditions: Voltage and auxiliary circuits energized with reference voltage;

Without any current in the current circuits.

Test severity: Temperature: 30 °C;
Humidity: 85 %;
Duration: 2 days.

Allowed effects: During the test no significant fault shall occur. Immediately after the test the meter shall operate correctly and comply with the accuracy requirements of Table 4.
24 h after the test the meter shall be submitted to a functional test during which it shall be demonstrated to operate correctly. There shall be no evidence of any mechanical damage or corrosion which may affect the functional properties of the meter.

6.4.16.4 Damp heat, cyclic (condensing) for humidity class H2 and H3

Applicable standards: IEC 60068-2-30, IEC 60068-3-4.

Object of the test: To verify compliance with the provisions in Table 4, 3.3.6.2 and Table 5 under conditions of high humidity and temperature variations. This test applies to meters with a humidity class specification either for enclosed locations where meters can be subjected to condensed water or for open locations (humidity classes H2 and H3).

Test procedure in brief: The test consists of exposure to cyclic temperature variation between 25 °C and the temperature specified as the upper temperature according to the test severities below, whilst maintaining the relative humidity above 95 % during the temperature change and low temperature phases, and at 93 % during the upper temperature phases. Condensation should occur on the meter during the temperature rise.

The 24 h cycle consists of

- 1) temperature rise during 3 h,
- 2) temperature maintained at upper value until 12 h from the start of the cycle,
- 3) temperature reduced to lower value within 3 h to 6 h, the rate of fall during the first hour and a half being such that the lower value would be reached in 3 h,
- 4) temperature maintained at lower value until the 24 h cycle is completed.

The stabilizing period before and recovery after the cyclic exposure shall be such that all parts of the meter are within 3 °C of their final temperature.

Test conditions: Voltage and auxiliary circuits energized with reference voltage;
Without any current in the current circuits;
Mounting position according to manufacturer’s specification.

Test severities: Meters with a humidity class specification for enclosed locations where meters can be subjected to condensed water shall be tested at severity level 1. Meters with a humidity class specification for open locations shall be tested at severity level 2.

Specified humidity class:	H2	H3
Severity levels:	1	2
Upper temperature (°C):	40	55
Duration (cycles):	2	2

Allowed effects: During the test no significant fault shall occur.
Immediately after the test the meter shall operate correctly and comply with the accuracy requirements of Table 4.

24 h after the test the meter shall be submitted to a functional test during which it shall be demonstrated to operate correctly. There shall be no evidence of any mechanical damage or corrosion which may affect the functional properties of the meter.

6.4.16.5 Water test

Applicable standards: IEC 60068-2-18, IEC 60512-14-7, IEC 60529.

Object of the test: To verify compliance with the provisions in 3.3.6.2 and Table 5 under conditions of rain and water splashes. The test is applicable to meters that are specified for open locations (H3).

Test procedure in brief: The meter is mounted on an appropriate fixture and is subjected to impacting water generated from either an oscillating tube or a spray nozzle used to simulate spraying or splashing water.

Test conditions: The meter shall be in functional mode during the test;

Flow rate (per nozzle): 0.07 L/min;

Duration: 10 min;

Angle of inclination: 0° and 180°.

Allowed effects: During the test no significant fault shall occur.

Immediately after the test the meter shall operate correctly and comply with the accuracy requirements of Table 2.

24 h after the test the meter shall be submitted to a functional test during which it shall be demonstrated to operate correctly and comply with the accuracy requirements of Table 2. There shall be no evidence of any mechanical damage or corrosion which may affect the functional properties of the meter.

6.4.17 Durability test

~~Object of the test: To verify compliance with the provisions in 3.8 and Table 5 for durability.~~

~~Test procedure in brief: The test procedure for durability shall be taken from national or regional standards for durability of electricity meters.~~

~~Mandatory test points: For initial and final measurement, the voltage shall be U_{nom} , with the following test points: I_{tr} , $10 I_{tr}$, and I_{max} at PF=1.~~

7 Type evaluation and approval

An examination for type evaluation shall determine whether a meter complies with all requirements in section 3, and whether documentation supplied by the manufacturer complies with the requirements in section 4.1.

A meter may only be deemed to have passed examination for type approval if the results of all type tests comply with the requirements given in section 3. The measurement uncertainty shall be small enough to allow clear discrimination between a pass result and a fail result. In particular, an uncertainty less than one fifth the maximum permissible error given for the corresponding test point must be obtained for tests described in section 6.2, unless otherwise specified in the relevant test description.

The scope of the tests performed and test severities used shall be consistent with the manufacturer's specifications and with the requirements of section 3.

8 Verification

8.1 General

~~Verification may be carried out either individually or statistically. In all cases meters shall conform to the requirements of this Recommendation. As noted in 3.3.3, national authorities may specify the base maximum permissible errors for subsequent verification and in-service inspections. The following minimum program~~

~~applies to the initial verification of all meters, whether verified individually or statistically, and to re-verification of meters which have been repaired or otherwise changed. For individual or statistical re-verification of meters that have not been repaired or otherwise changed, the program may be modified and further reduced.~~

~~The exact requirements for verification and in-service inspection shall be specified by the national authority.~~

~~8.2—Testing~~

~~8.2.1—Calibration status~~

~~Check that the test system used has sufficient accuracy to verify the meters under test, and that the calibration is valid.~~

~~8.2.2—Conformity check~~

~~Check that the instrument is manufactured in conformity with the type approval documentation.~~

~~8.2.3—Warming-up~~

~~It may be necessary to warm the meter up before full operation. The length of the warming-up period depends on the actual type of instrument and shall be determined in advance. During the test for initial intrinsic error the meter shall be allowed to stabilize at each current level before measurements for a period, no longer than 5 min, to be nominated by the manufacturer. The order of the test points shall be from lowest current to highest current and then from highest current to lowest current. For each test point, the resulting error shall be the mean of these measurements. For I_{\max} , the maximum measurement time shall be 10 min including stabilizing time.~~

~~8.2.4—Minimum test program~~

~~The minimum program consists of:~~

- ~~• No load check;~~
- ~~• Starting current check;~~
- ~~• Current dependence;~~
- ~~• Check of the register.~~

~~8.2.4.1—No load check~~

~~For this test, there shall be no current in the current circuit. The test shall be performed at U_{nom} .~~

~~For meters with a test output, the output of the meter shall not produce more than one pulse. For an electromechanical meter, the rotor of the meter shall not make a complete revolution.~~

~~The minimum test period Δt shall be as specified in 6.2.4.~~

~~A meter with more than one connection mode shall be tested in all modes. However, if the test is made *in-situ* on an installed meter, only the actual mode of connection need be tested.~~

~~For transformer operated meters with primary rated registers where the value of k (and possibly U_{nom}) are given as primary side values, the constant k (and U_{nom}) shall be recalculated to correspond to secondary side values (of voltage and current).~~

~~8.2.4.2—Starting current check~~

~~The test is performed at I_{st} and unity power factor.~~

~~For initial verification of meters produced from a continuously operating process resulting in a large number of identical units, it is sufficient for the error curve from I_{st} to I_{min} to be recorded on a sample batch every 3 months for the particular meter type.~~

~~For initial verification of meters produced by other means, it will be sufficient if the meter is observed to run continuously when the starting current is applied (refer to the test procedure in 6.2.3).~~

A meter with more than one connection mode shall be tested in all modes. However, if the test is made *in situ* on an installed meter, only the actual mode of connection need be tested.

8.2.4.3 — Current dependence

Meters shall comply with the accuracy requirements of Table 2. As a minimum these shall be checked at the following currents:

- ~~I_{\min} , PF = 1;~~
- ~~I_{tr} , PF = 1;~~
- ~~I_{tr} , PF = 0.5 inductive;~~
- ~~$10 I_{tr}$, PF = 1;~~
- ~~$10 I_{tr}$, PF = 0.5 inductive;~~
- ~~I_{\max} , PF = 1;~~
- ~~I_{\max} , PF = 0.5 inductive.~~

In the case of three phase meters with an alternative single phase connection mode or which are being used as two phase meters, the single phase load test shall be performed separately for each phase at:

- ~~$10 I_{tr}$, PF = 1; and~~
- ~~$10 I_{tr}$, PF = 0.5 inductive.~~

For meters with alternate connection modes, such as one phase connections for poly phase meters or meters being used as two phase meters, this test shall be performed separately for each connection mode.

8.2.4.4 — Check of the register

If test (pulse) outputs are used for tests of accuracy requirements, a test must be performed to ensure that the relation between the basic energy register and the relevant test output(s) complies with that specified by the manufacturer.

The test shall be performed by passing a quantity of energy E through the meter, where $E \geq E_{\min}$ specified in 6.2.5:

The energy put through the meter shall be calculated using the number of pulses from the test output; the relative difference between this energy and the energy registered shall be determined. This relative difference must not be greater than one tenth of the base maximum permissible error.

The test shall be performed at a single arbitrary current $I \geq I_{tr}$.

8.2.5 — Sealing

If there are no seals on the meter (e.g. because they have not yet been applied or because they have been removed during verification testing), the meter shall be sealed in accordance with the requirements specified by national authorities.

8.3 — Reference conditions for initial and subsequent verifications in a laboratory

Reference conditions and load conditions for initial and subsequent verifications in a laboratory are given in Tables 16 and 17. National authorities may specify tighter tolerances.

Table 16 Reference conditions and their tolerances for initial and subsequent verification

Quantity	Reference conditions	Tolerance
Voltage(s)	U_{nom}	$\pm 2\%$
Ambient temperature	23 °C	$\pm 5\text{°C}$
Frequency	f_{nom}	$\pm 0.5\%$
Wave form	Sinusoidal	$d \leq 2\%$
Magnetic induction of external origin at reference frequency	0 T	$B \leq 0.1\text{ mT}$
Electromagnetic RF fields 30 kHz—6 GHz	0 V/m	$< 2\text{ V/m}$
Operating position for instruments sensitive to position	Mounting as stated by manufacturer	$\pm 3.0\text{°}$
Phase sequence for poly-phase meters	L1, L2, L3	-
Load balance	Equal current in all current circuits	$\pm 5\%$ and $\pm 5\text{°}$

Table 17 Load conditions and their tolerances in tests for initial and subsequent verification

Current(s)	Current range of device under test	Class A, B: $\pm 10\%$ Class C, D: $\pm 10\%$
Power factor	Power factor range of device under test	current to voltage phase difference $\pm 5\text{°}$

8.4—Additional requirements for statistical verifications

This section contains additional requirements for verification on a statistical basis.

Note:—National authorities shall determine whether the use of statistical methods is permitted.

8.4.1—Lot

A lot shall consist of meters with homogeneous characteristics. All meters that comprise the lot shall correspond to the same type approval, and shall have the same year of manufacture.

8.4.2—Samples

Samples shall be randomly taken from a lot.

8.4.3—Statistical testing

The statistical control shall be based on attributes. The sampling system shall ensure:

- An Acceptance Quality Level (AQL) of not more than 1 %; and
- A Limiting Quality (LQ) of not more than 7 %.

The AQL is the maximum percentage of non-conforming items in a lot at which the lot has a probability of 95 % to be accepted.

The LQ is the percentage of non-conforming items in a lot at which the lot has a maximum probability of 5 % to be accepted.

Note:—These requirements allow for substantial freedom in the verification program. Examples are given below based on a lot of 1000 meters.

Number of meters tested	40	70	100	1000
-------------------------	----	----	-----	------

Maximum number of non-conforming meters.	0	1	2	10
---	--------------	--------------	--------------	---------------

~~8.5—Additional requirements for statistical in-service inspections~~

~~Guidance for in-service inspections of utility meters is now being drafted by OIML TC 3/SC 4 [6].~~

Annex A Bibliography

(Informative)

Ref.	Standards and reference documents	Description
[1]	OIML D 11 (2004) General requirements for electronic measuring instruments	Guidance for establishing appropriate metrological performance testing requirements for influence quantities that may affect the measuring instruments covered by International Recommendations.
[2]	OIML D 31 (2008) General requirements for software controlled measuring instruments	Guidance for establishing appropriate requirements for software related functionalities in measuring instruments covered by OIML Recommendations.
[3]	OIML V 2-200 (2012) International Vocabulary of Metrology – Basic and General Concepts and Associated Terms (VIM)	Vocabulary, prepared by a joint working group consisting of experts appointed by BIPM, IEC, IFCC, ISO, IUPAC, IUPAP, and OIML
[4]	OIML V 1 (2000) International vocabulary of terms in legal metrology (VIML)	The VIML includes only the concepts used in the field of legal metrology. These concepts concern the activities of the legal metrology service, the relevant documents, as well as other problems linked with this activity. Also included in this Vocabulary are certain concepts of a general character which have been drawn from the VIM.
[5]	OIML G 1-100 (2008), (GUM) Evaluation of measurement data - Guide to the expression of uncertainty in measurement	This Guide establishes general rules for evaluating and expressing uncertainty in measurement that are intended to be applicable to a broad spectrum of measurements.
[6]	OIML TC 3/SC 4, 3 rd committee draft, 13 July 2010 Surveillance of utility meters in service on the basis of sampling inspections	This is a draft OIML Document that relates to the method and procedure according to which the period of validity of the verification of utility meters forming part of a defined lot is extended if the correctness of the meters has been proved by sampling inspections prior to the expiry of the period of validity of the verification.
[7]	IEC 60060-1 ed 3.0 (2010) High-voltage Test Techniques. Part 1: General Definitions and Test Requirements	This part of IEC 60060 is applicable to: – dielectric tests with direct voltage; – dielectric tests with alternating voltage; – dielectric tests with impulse voltage; – dielectric tests with combinations of the above.
[8]	IEC 60068-2-1 (2007) Environmental testing. Part 2: Tests. Test A: Cold	This part of IEC 60068 deals with cold tests applicable to both non heat-dissipating and heat-dissipating specimens. The object of the cold test is limited to the determination of the ability of components, equipment or other articles to be used, transported or stored at low temperature. Cold tests covered by this Standard do not enable the ability of specimens to withstand or operate during the temperature variations to be assessed. In this case, it would be necessary to use IEC 60068-2-14.
[9]	IEC 60068-2-2 (2007) Environmental testing. Part 2: Tests. Test B: Dry heat	This part of IEC 60068 deals with dry heat tests applicable both to heat-dissipating and non heat-dissipating specimens.

		<p>The object of the dry heat test is limited to the determination of the ability of components, equipment or other articles to be used, transported or stored at high temperature.</p> <p>These dry heat tests do not enable the ability of specimens to withstand or operate during the temperature variations to be assessed. In this case, it would be necessary to use IEC 60068-2-14 Test N: Change of temperature.</p>
[10]	IEC 60068-2-18 (2000) Environmental testing. Part 2- Test R and guidance: Water	Provides methods of test applicable to products which, during transportation, storage or in service, may be subjected to falling drops, impacting water or immersion. The primary purpose of water tests is to verify the ability of enclosures, covers and seals to maintain components and equipment in good working order after and, when necessary, under a standardized dropfield or immersion in water.
[11]	IEC 60068-2-27 Ed. 4.0 (2008) Environmental testing - Part 2-27: Tests - Test Ea and guidance: Shock	Provides a standard procedure for determining the ability of a specimen to withstand specified severities of non-repetitive or repetitive shocks. The purpose of this test is to reveal mechanical weakness and/or degradation in specified performances, or accumulated damage or degradation caused by shocks.
[12]	IEC 60068-2-30 (2005) Environmental testing. Part 2-30: Tests. Test Db: Damp heat, cyclic (12+12-hour cycle)	Determines the suitability of components, equipment and other articles for use and/or storage under conditions of high humidity when combined with cyclic temperature changes.
[13]	IEC 60068-2-47 (2005) Environmental testing - Part 2-47: Test - Mounting of specimens for vibration, impact and similar dynamic tests	Provides methods of mounting components, and mounting requirements for equipment and other articles, for the families of dynamic tests in IEC 60068-2, that is impact (Test E), vibration (Test F) and acceleration, steady-state (Test G).
[14]	IEC 60068-2-64 (2008) Environmental testing - Part 2: Test methods - Test Fh: Vibration, broad-band random (digital control) and guidance	<p>Determines the ability to withstand specified severities of broad-band random vibration. Applies to specimens which may be subjected to vibration of a stochastic nature by transportation or operational environments, for example in aircraft, space vehicles and land vehicles.</p> <p>Has the status of a basic safety publication in accordance with IEC Guide 104.</p>
[15]	IEC 60068-2-78 (2001) Environmental testing - Part 2-78: Tests - Test Cab: Damp heat, steady state	Provides a test method for determining the suitability of electrotechnical products, components or equipment for transportation, storage and use under conditions of high humidity. The test is primarily intended to permit the observation of the effect of high humidity at constant temperature without condensation on the specimen over a prescribed period.
[16]	IEC 60068-3-1 Ed 2.0 (2011-08) Environmental testing - Part 3-1: Supporting documentation and guidance - Cold and dry heat tests	Gives background information for Tests A: Cold (IEC 68-2-1), and Tests B: Dry heat (IEC 68-2-2). Includes appendices on the effect of: chamber size on the surface temperature of a specimen when no forced air circulation is used; airflow on chamber conditions; on surface temperatures of test specimens; wire termination dimensions and material on surface temperature of a component; measurements of temperature, air velocity and emission coefficient.
[17]	IEC 60068-3-4 (2001)	Provides the necessary information to assist in preparing relevant specifications, such as standards for components or

	Environmental testing. Part 3-4- Supporting documentation and guidance - Damp heat tests	equipment, in order to select appropriate tests and test severities for specific products and, in some cases, specific types of application. The object of damp heat tests is to determine the ability of products to withstand the stresses occurring in a high relative humidity environment, with or without condensation, and with special regard to variations of electrical and mechanical characteristics. Damp heat tests may also be utilized to check the resistance of a specimen to some forms of corrosion attack.
[18]	IEC 60512-14-7 (1997) Electromechanical components for electronic equipment - Basic testing procedures and measuring methods - Part 14: Sealing tests - Section 7: Test 14g: Impacting water	Defines a standard test method to assess the effects of impacting water or specified fluid on electrical connecting devices.
[19]	IEC 60529 (2001), Corrigenda IEC 60529-cor1 (2003), IEC 60529-cor2 (2007) and IEC 60529 Corr.3 (2009-10) Degrees of protection provided by enclosures (IP Code)	Applies to the classification of degrees of protection provided by enclosures for electrical equipment with a rated voltage not exceeding 72.5 kV. Has the status of a basic safety publication in accordance with IEC Guide 104.
[20]	IEC 61000-4-1 (2006) Electromagnetic compatibility (EMC) - Part 4-1: Testing and measurement techniques - Overview of IEC 61000-4 series	Gives applicability assistance to the users and manufacturers of electrical and electronic equipment on EMC standards within the IEC 61000-4 series on testing and measurement techniques. Provides general recommendations concerning the choice of relevant tests.
[21]	IEC 61000-4-2 (2008) Electromagnetic compatibility (EMC) - Part 4-2: Testing and measurement techniques - Electrostatic discharge immunity test	Relates to the immunity requirements and test methods for electrical and electronic equipment subjected to static electricity discharges, from operators directly, and to adjacent objects. Additionally defines ranges of test levels which relate to different environmental and installation conditions and establishes test procedures. The object of this standard is to establish a common and reproducible basis for evaluating the performance of electrical and electronic equipment when subjected to electrostatic discharges. In addition, it includes electrostatic discharges which may occur from personnel to objects near vital equipment.
[22]	IEC 61000-4-3 (2010). Electromagnetic compatibility (EMC). Part 4-3: Testing and measurement techniques - Radiated, radio-frequency, electromagnetic field immunity test	Applies to the immunity of electrical and electronic equipment to radiated electromagnetic energy. Establishes test levels and the required test procedures. Establishes a common reference for evaluating the performance of electrical and electronic equipment when subjected to radio-frequency electromagnetic fields.
[23]	IEC 61000-4-4 (2012) Electromagnetic compatibility (EMC). Part 4-4: Testing and measurement techniques - Electrical fast transient/burst immunity tests	Establishes a common and reproducible reference for evaluating the immunity of electrical and electronic equipment when subjected to electrical fast transient/burst on supply, signal, control and earth ports. The test method documented in this part of IEC 61000-4 describes a consistent method to assess the immunity of an equipment or system against a defined phenomenon.
[24]	IEC 61000-4-5 (2005), corr. 1 (2009-10)	Relates to the immunity requirements, test methods, and range of recommended test levels for equipment to unidirectional surges caused by overvoltages from switching

	Electromagnetic compatibility (EMC). Part 4-5: Testing and measurement techniques - Surge immunity test	and lightning transients. Several test levels are defined which relate to different environment and installation conditions. These requirements are developed for and are applicable to electrical and electronic equipment. Establishes a common reference for evaluating the performance of equipment when subjected to high-energy disturbances on the power and inter-connection lines.
[25]	IEC 61000-4-6 (2008) Electromagnetic compatibility (EMC) - Part 4-6: Testing and measurement techniques - Immunity to conducted disturbances, induced by radio-frequency fields	Relates to the conducted immunity requirements of electrical and electronic equipment to electromagnetic disturbances coming from intended radio-frequency (RF) transmitters in the frequency range 9 kHz - 80 MHz. Equipment not having at least one conducting cable (such as mains supply, signal line or earth connection), which can couple the equipment to the disturbing RF fields is excluded.
[26]	IEC 61000-4-8, Ed. 2.0 (2009-09) Electromagnetic compatibility (EMC) - Part 4-8: Testing and measurement techniques - Power frequency magnetic field immunity test	Relates to the immunity requirements of equipment, only under operational conditions, to magnetic disturbances at power frequency related to: <ul style="list-style-type: none"> – residential and commercial locations; – industrial installations and power plants; and – medium voltage and high voltage sub-stations.
[27]	IEC 61000-4-11 (2004) Electromagnetic compatibility (EMC). Part 4-11: Testing and measurement techniques -: Voltage dips, short interruptions and voltage variation immunity tests	Defines the immunity test methods and range of preferred test levels for electrical and electronic equipment connected to low-voltage power supply networks for voltage dips, short interruptions, and voltage variations. This standard applies to electrical and electronic equipment having a rated input current not exceeding 16 A per phase, for connection to 50 Hz or 60 Hz a.c. networks.
[28]	IEC 61000-4-12 (2006) Electromagnetic compatibility (EMC) - Part 4-12: Testing and measurement techniques - Ring wave immunity test	Relates to the immunity requirements and test methods for electrical and electronic equipment, under operational conditions, to non-repetitive damped oscillatory transients (ring waves) occurring in low-voltage power, control and signal lines supplied by public and non-public networks.
[29]	IEC 61000-6-1(2005) Electromagnetic compatibility (EMC) - Part 6-1: Generic standards - Immunity for residential, commercial and light-industrial environments	Defines the immunity test requirements in relation to continuous and transient, conducted and radiated disturbances, including electrostatic discharges, for electrical and electronic apparatus intended for use in residential, commercial and light-industrial environment, and for which no dedicated product or product-family standard exists. Immunity requirements in the frequency range 0 kHz - 400 GHz are covered and are specified for each port considered. This standard applies to apparatus intended to be directly connected to a low-voltage public mains network or connected to a dedicated DC source which is intended to interface between the apparatus and the low-voltage public mains network.
[30]	IEC 61000-6-2 (2005) Electromagnetic compatibility (EMC) - Part 6-2: Generic standards - Immunity for industrial environments	Applies to electrical and electronic apparatus intended for use in industrial environments, for which no dedicated product or product-family immunity standard exists. Immunity requirements in the frequency range 0 Hz - 400 GHz are covered, in relation to continuous and transient, conducted and radiated disturbances, including electrostatic discharges. Test requirements are specified for each port considered.

		<p>Apparatus intended to be used in industrial locations are characterized by the existence of one or more of the following:</p> <ul style="list-style-type: none"> - a power network powered by a high or medium voltage power transformer dedicated to the supply of an installation feeding manufacturing or similar plant; - industrial, scientific and medical (ISM) apparatus; - heavy inductive or capacitive loads that are frequently switched; - currents and associated magnetic fields that are high.
[31]	IEC 62052-11 (2003) Electricity metering equipment (AC) - General requirements, tests and test conditions - Part 11: Metering equipment	Covers type tests for electricity metering equipment for indoor and outdoor application and to newly manufactured equipment designed to measure the electric energy on 50 Hz or 60 Hz networks, with a voltage up to 600 V. It applies to electromechanical or static meters for indoor and outdoor application consisting of a measuring element and register(s) enclosed together in a meter case. It also applies to operation indicator(s) and test output(s)
[32]	IEC 62053-52 (2005) Electricity metering equipment (AC) - Particular requirements - Part 52: Symbols	Applies to letter and graphical symbols intended for marking on and identifying the function of electromechanical or static a.c. electricity meters and their auxiliary devices. The symbols specified in this standard shall be marked on the name-plate, dial plate, external labels or accessories, or shown on the display of the meter as appropriate.
[33]	IEC 62054-21 (2005) Electricity metering (a.c.) – Tariff and load control – Part 21: Particular requirements for time switches	Specifies particular requirements for newly manufactured indoor time switches with operation reserve that are used to control electrical loads, multi-tariff registers and maximum demand devices of electricity metering equipment.
[34]	ISO 4892-3 Plastics – Methods of exposure to laboratory light sources – Part 3: Fluorescent UV lamps	Specifies methods for exposing specimens to fluorescent UV radiation and water in apparatus to designed reproduce the weathering effects that occur when materials are exposed in actual end-use environments to daylight, or to daylight through window glass.

Annex B

Estimation of combined errors

(Informative)

B.1 Estimate of combined maximum permissible error based on the requirements of this Recommendation

This Recommendation permits a base maximum permissible error plus an error shift caused by influence quantities. The actual error of a complying meter when in use could therefore exceed the base maximum permissible error. There is a need to estimate an overall maximum permissible error that indicates the largest error that can reasonably be attributed to a meter type that complies with this Recommendation. This entails estimating the errors of a measurement of an arbitrary meter within the rated operating conditions.

However, adding the base maximum permissible error and all error shifts algebraically would give a much too pessimistic estimate of the metering uncertainty, for two reasons. For an arbitrary set of influence factor values, some of the error shifts will be low and some will probably have opposite signs, tending to cancel each other out. Furthermore, the electricity meter is an integrating device, thus the errors caused by influence quantities will average out to some extent as the values of the influence factors vary over time.

If we make the following assumptions:

- a) the integrating effect may be ignored,
- b) none of the effects of the influence factors are correlated,;
- c) the values of the influence quantities are more likely to be close to the reference values than to limits of the rated operated conditions,
- d) the influence quantities, and the effects of the influence factors, can be treated as Gaussian distributions, and thus a value of half the maximum permissible error shift can be used for the standard uncertainty,

then the combined maximum permissible error (assuming a coverage factor of two corresponding to a coverage probability of approximately 95 %) can be estimated using the formula⁽¹⁾:

$$v = 2 * \sqrt{\frac{v_{base}^2}{4} + \frac{v_{voltage}^2}{4} + \frac{v_{frequency}^2}{4} + \frac{v_{unbalance}^2}{4} + \frac{v_{harmonic}^2}{4} + \frac{v_{temperature}^2}{4}}$$

where:

v_{base} is the base maximum permissible error;

$v_{voltage}$ is the maximum error shift permitted for voltage variation;

$v_{frequency}$ is the maximum error shift permitted for frequency variation;

$v_{unbalance}$ is the maximum error shift permitted for unbalance variation;

$v_{harmonics}$ is the maximum error shift permitted for the variation of harmonic content;

$v_{temperature}$ is the maximum error shift permitted for temperature variation.

Note (1): This is in line with the ISO *Guide to the expression of uncertainty of measurement* (GUM).

B.2 Estimation of combined error based on type test results and specific conditions

B.2.1 Method 1

The combined maximum error can also be estimated for a particular meter type using type test results. Type test results can often show a smaller variation than that required by this Recommendation, leading to an assured smaller value for the overall maximum error.

Keeping the assumption of a Gaussian distribution being valid the combined maximum error can then be estimated from a combination of test results using the formula ⁽³⁾:

$$e_{c(p,i)} = \sqrt{(e^2(PF_p, I_i) + \delta e_{p,i}^2(T) + \delta e_{p,i}^2(U) + \delta e_{p,i}^2(f))}$$

where:

For each current I_i and each power factor PF_p

- $e(PF_p, I_i)$ is the intrinsic error of the meter measured in the course of the tests, at current I_i and power factor PF_p ;
- $\delta e_{p,i}(T)$, $\delta e_{p,i}(U)$, $\delta e_{p,i}(f)$ are the maximum additional errors measured in the course the test, when the temperature, the voltage and the frequency are respectively varied over the whole range specified in the rated operated conditions, at current I_i and power factor PF_p

B.2.2 Method 2

When assuming that a Gaussian distribution may no longer be valid, instead a rectangular distribution should be assumed for the effects of influence factors.

Thus, the combined maximum error can then be estimated from a combination of test results using the formula ⁽³⁾:

$$e_c = 2 * \sqrt{\frac{e_{base}^2}{3} + \frac{e_{voltage}^2}{3} + \frac{e_{frequency}^2}{3} + \frac{e_{unbalance}^2}{3} + \frac{e_{harmonic}^2}{3} + \frac{e_{temperature}^2}{3}}$$

where:

e_{base} is the maximum error obtained in the test for base maximum error, taking into account the measurement uncertainty of the type test⁽²⁾;

$e_{voltage}$ is the maximum error shift obtained in the test for voltage variation, taking into account the measurement uncertainty of the type test;

$e_{frequency}$ is the maximum error shift obtained in the test for frequency variation, taking into account the measurement uncertainty of the type test;

$e_{unbalance}$ is the maximum error shift obtained in the test for unbalance variation, taking into account the measurement uncertainty of the type test;

$e_{harmonics}$ is the maximum error shift obtained in the test for variation of harmonic content, taking into account the measurement uncertainty of the type test;

$e_{temperature}$ is the maximum error shift obtained in the test for temperature variation, taking into account the measurement uncertainty of the type test.

Note (2): The measurement uncertainty must be included in each component e_i of the overall error. Since one term is a known value and the other an uncertainty they cannot be treated as two uncorrelated statistical distributions, and must hence be added algebraically.

Note (3): Components contributing to the combined error may be selected by national or regional authorities and should at least comprise: e_{base} , $e_{frequency}$, $e_{temperature}$ and $e_{voltage}$.

The effects of correlations between factors such as load profiles and ambient temperature variation on meter accuracy have not been included in the above calculations, but could be modeled in situations where appropriate.

Annex C

Legislative matters

(Informative)

C.1 Legislative considerations

It would be impractical to develop this Recommendation to fit each and every one of the wide variety of situations and meter applications which exist around the world. It is therefore inevitable that some issues may need to be addressed by national authorities or at a regional level.

One way in which this Recommendation seeks to provide an appropriate balance between flexibility and uniformity is by the provision of options for a number of conditions, such as:

- a) Nominal voltage;
- b) Nominal frequency;
- c) Rated temperature;
- d) Level of protection from water and humidity;
- e) Level of protection from impulse voltages;
- f) Handling of energy flow direction.

It should be noted that in some countries or regions, local legislation may also include specific requirements relating to matters such as:

- g) Electrical interface;
- h) Mechanical interface and housing.

It should also be noted that, while the maximum current is most often specified by the characteristics of the installation, the value of the transitional current and/or the ratio between the maximum current and the transitional current are important for end customers with low power consumption, since these customers could experience large relative metering errors if the load current is lower than the transitional current for a large part of the time. It is thus recommended that the values of I_{tr} and I_{max} be chosen from Table 18.

Table 18 Preferred current ranges

Type of meter connection	Preferred values of I_{tr} and I_{max} (Amperes)	Other values of I_{tr} and I_{max} (Amperes)
Direct connection	Standard I_{tr} values: 0.125, 0.25, 0.5, 1, 2, 3. Standard I_{max} values: 10, 20, 40, 60, 80, 100, 120, 200, 320	Other I_{tr} values: 0.75, 1.5, 2.5, 4, 5 Other I_{max} values: 30, 50, 160
Connection through current transformer(s)	Standard I_{tr} values: 0.05, 0.1, 0.25 Standard I_{max} values: 1.2, 1.5, 2, 2.4, 3, 4, 6, 7.5, 10, 20	Other I_{tr} values: 0.125 Other I_{max} values 3.75, 5

Note 1: The current range of transformer operated meters should be compatible with the current range of current transformers.

Note 2: The legislator may prescribe the maximum permissible I_{tr} value, prescribe a minimum current range, or a minimum ratio between I_{max} and I_{tr} . These can be prescribed as absolute values or values based on the typical power demand for certain types of customers etc.

C.1.1 Choice of accuracy class

More accurate meters should be used when metering large flows of electricity in order to minimize the economic impact of unavoidable measurement errors. While class A meters may be acceptable for situations

involving low energy consumption, higher class indices should be used when higher rates of energy consumption are involved.

The accuracy of the meter will be independent of the power grid characteristics for most meter connection modes; however, there may be a need to evaluate the influence of grid characteristics, especially for meters with higher class indices, in cases where there are underlying assumptions of grid symmetry and/or lack of leakage currents. It is possible that contributions to the overall meter error due to grid characteristics in such situations may be larger than contributions from the meter itself, especially at higher accuracy; it may therefore be appropriate to limit the use of connection modes of this type.

C.1.2 Matters not covered by the scope of this Recommendation

This Recommendation is limited to describing the relevant metrological requirements of an electricity meter and therefore does not cover certain matters which may or should be regulated by legislation, such as:

- a) EMC emissions;
- b) Electrical safety and personal safety;
- c) Security of communication protocols and further handling of measurement results.