



Australian Government
**National Measurement
Institute**



NMI R 71 Fixed Storage Tanks. General Requirements

(OIML R 71:2008(E), IDT)

The English version of international standard OIML R 71: 2008 *Fixed Storage Tanks. General Requirements* is adopted as the identical national standard with the reference number NMI R 71

© Commonwealth of Australia 1993

First edition — February 1993 (OIML R 71:1993 adopted as Document 124)
First edition, first revision — November 2001 (renamed NSC R 71)
First edition, second revision — July 2004 (renamed NMI R 71)
Second edition — February 2013 (OIML R 71:2008 adopted as NMI R 71)

National Measurement Institute
Bradfield Road, Lindfield, NSW 2070
PO Box 264, Lindfield, NSW 2070

T (61 2) 8467 3600
F (61 2) 8467 3610
W www.measurement.gov.au

1. SCOPE

NMI R 71 specifies the general requirements for fixed (stationary) storage tanks onshore with fixed or floating roofs including pressured, non-pressured, refrigerated and non-refrigerated tanks.

2. CONTENTS

NMI R 71 is identical to OIML R 71:2008 *Fixed Storage Tanks. General Requirements* published by the International Organisation of Legal Metrology (OIML).

3. VARIATIONS AND INTERPRETATIONS

Please note:

- References to 'this Recommendation' substitute 'NMI R 71'.
- References to 'national regulations' substitute 'the Regulations'.
- References to 'competent authority' substitute 'National Measurement Institute'.
- References to 'OIML R 85' and 'OIML R 85-1/2' substitute 'NMI R 85-1 & 2'.
- References to 'OIML R 35-1' substitute 'NMI M 1'.
- References to 'type approval' substitute 'pattern approval'.
- References to 'initial verification' and 'subsequent verification' substitute 'verification'.

INTERNATIONAL
RECOMMENDATION

OIML R 71
Edition 2008 (E)

Fixed storage tanks. General requirements

Réservoirs de stockage fixes. Prescriptions générales



Contents

<i>Foreword</i>	4
1 Introduction	5
2 Scope	5
3 Terminology	5
4 Classification and description	7
5 Units of measurement	7
6 Technical characteristics of tanks	7
7 Metrological characteristics of tanks	8
8 Metrological controls	9
9 Additional information of the specific types of tanks	11
Annex A Practical solutions	13
Annex B Examples of location of gauge hatches and of realization of the reference points	16
Annex C Bibliography	20

Foreword

The International Organization of Legal Metrology (OIML) is a worldwide, intergovernmental organization whose primary aim is to harmonize the regulations and metrological controls applied by the national metrological services, or related organizations, of its Member States. The main categories of OIML publications are:

- **International Recommendations (OIML R)**, which are model regulations that establish the metrological characteristics required of certain measuring instruments and which specify methods and equipment for checking their conformity. OIML Member States shall implement these Recommendations to the greatest possible extent;
- **International Documents (OIML D)**, which are informative in nature and which are intended to harmonize and improve work in the field of legal metrology;
- **International Guides (OIML G)**, which are also informative in nature and which are intended to give guidelines for the application of certain requirements to legal metrology; and
- **International Basic Publications (OIML B)**, which define the operating rules of the various OIML structures and systems.

OIML Draft Recommendations, Documents and Guides are developed by Technical Committees or Subcommittees which comprise representatives from the Member States. Certain international and regional institutions also participate on a consultation basis. Cooperative agreements have been established between the OIML and certain institutions, such as ISO and the IEC, with the objective of avoiding contradictory requirements. Consequently, manufacturers and users of measuring instruments, test laboratories, etc. may simultaneously apply OIML publications and those of other institutions.

International Recommendations, Documents, Guides and Basic Publications are published in English (E) and translated into French (F) and are subject to periodic revision.

Additionally, the OIML publishes or participates in the publication of **Vocabularies (OIML V)** and periodically commissions legal metrology experts to write **Expert Reports (OIML E)**. Expert Reports are intended to provide information and advice, and are written solely from the viewpoint of their author, without the involvement of a Technical Committee or Subcommittee, nor that of the CIML. Thus, they do not necessarily represent the views of the OIML.

This publication - reference OIML R 71, edition 2008 (E) - was developed by the OIML Technical Subcommittee TC 8/SC 1 *Static volume and mass measurement*. It was sanctioned for final publication by the International Conference of Legal Metrology in 2008. This Edition supersedes the previous edition of OIML R 71 (Edition 1985).

OIML Publications may be downloaded from the OIML web site in the form of PDF files. Additional information on OIML Publications may be obtained from the Organization's headquarters:

Bureau International de Métrologie Légale
11, rue Turgot - 75009 Paris - France
Telephone: 33 (0)1 48 78 12 82
Fax: 33 (0)1 42 82 17 27
E-mail: biml@oiml.org
Internet: www.oiml.org

Fixed storage tanks

General requirements

1 Introduction

The revision of this Recommendation was made necessary by the revision of OIML R 85 (1998) “Automatic level gauges for measuring the level of liquid in fixed storage tanks”.

The requirements for tanks and gauges have now been separated, and R 71 has been completed with test procedures.

As a result, R 71 has been completely redrafted, including a revision of the structure of this Recommendation.

2 Scope

2.1 Fixed storage tanks at atmospheric pressure or under pressure (hereinafter called “tanks”) are built for bulk liquid storage and may be used for the measurement of quantities (volume or mass) of liquid contained. When used for that measurement, they shall comply with the requirements of this Recommendation.

2.2 In addition to the requirements for parts of the tank, such as the gauging hatch and datum plate, the calibration table should be accurately determined as it is a component of the measurement of quantity (volume or mass) of liquid in the tank.

2.3 This Recommendation specifies the general requirements for all stationary storage tanks onshore with fixed or floating roofs including pressured, non-pressured, refrigerated and non refrigerated tanks. Additional information for the different types of tanks is stated in clause 9.

3 Terminology

3.1 Calibration

Set of operations carried out to establish, under specified conditions, the relationship between the liquid level in the tank and the volume of that liquid.

3.2 Nominal capacity

Rounded value of the maximum volume of liquid that a tank may contain under normal conditions of use.

3.3 Gauge hatch (Dip-hatch)

Opening in the top of a tank through which dipping and sampling operations are carried out.

3.4 Vertical measurement axis

Vertical line which passes through the middle of the still well (guide pipe), if provided, belonging to the gauge hatch concerned, and corresponding to the position intended for automatic or manual level gauges.

3.5 Dipping datum plate (see Annex A)

Horizontal plate located along the vertical axis descending from the upper reference point, providing a fixed contact surface from which manual liquid depth measurements are made.

Note: The term “datum plate” is synonymous.

3.6 Dipping datum point

Intersection of the vertical measurement axis with the upper surface of the dipping datum plate, or with the bottom surface of the tank if a dipping datum plate is not provided. It constitutes the origin for the measurement of liquid levels (zero reference or dipping reference point).

3.7 Upper reference point

Point located on the vertical measurement axis, with reference to which the ullage is measured.

3.8 Reference height

Distance between the dipping datum point and the upper reference point.

3.9 Ullage

Distance between the free surface of the liquid and the upper reference point, measured along the vertical measurement axis.

3.10 Reference conditions

Reference conditions applicable for the calibration certificate.

3.11 Automatic level gauge (ALG)

Instrument intended to measure automatically and display the level of the liquid contained in a tank with respect to a fixed reference.

An automatic level gauge includes at least a liquid level sensor, a transducer, and an indicating device.

Note: See OIML Recommendation R 85-1/2 for general requirements.

3.12 Deadwood

Tank fittings, structure, piping and other equipment which affects the capacity of a tank.

Deadwood is referred to as “positive deadwood” when the capacity of the fitting adds to the effective capacity of the tank, or “negative deadwood” when the volume of the fitting displaces liquid and reduces the effective capacity.

3.13 Calibration table

Expression in the form of a table, of the mathematical function $V(h)$ which represents the relation between the height h (independent variable) and the volume V (dependent variable).

3.14 Lower limit of accurate capacity

Capacity below which the maximum permissible error is exceeded, taking account of the shape of the tank and the calibration method.

3.15 Dipping tape

Material measure of length for measuring the liquid level.

Note: See OIML Recommendation R 35-1 for general requirements.

4 Classification and description

Regarding their calibration and the establishing of calibration tables, the tanks may be classified according to the following criteria (more information is given in clause 9):

- shape (9.1.1);
- position with reference to the ground (9.1.2);
- means used for measuring levels or volumes (quantities) of liquid contained (9.1.3);
- kind of liquid(s) to be contained (hydrostatic pressure; 9.1.4);
- conditions of use (supplementary influence quantities; 9.1.4).

5 Units of measurement

The authorized units of measurement are those of the International System of Units (SI).

If, in any country, units of measurement outside the SI are authorized, the legal units of measurement of that country may be used. In international trade, the officially agreed equivalents between these units of measurement and those of the SI shall be applied.

6 Technical characteristics of tanks

6.1 The tanks shall be built in accordance with sound engineering practice. With reference to their construction, position and conditions of use, the tanks shall comply with the legal requirements for storage of contained liquids, in relation to the characteristics of these liquids (potable, petroleum, chemical, etc.).

6.2 The tanks may be provided with devices necessary to reduce, as much as practical, evaporative losses. Installation and the use of these devices shall not lead to serious measurement errors.

6.3 In order to be accepted for fiscal / custody transfer applications, the tanks shall comply with the following general requirements, which aim to ensure the accuracy of measurement of the volume of liquid contained:

- (a) The shape, material, reinforcement, construction and assembly shall be such that the tank is sufficiently resistant to the atmosphere and the effects of the contained liquid and that, under normal conditions of use, it suffers no serious deformation which may adversely affect the capacity of the tank;
- (b) The dipping datum point and the upper reference point shall be constructed so that their positions remain practically most stable, minimizing the impact due to tank filling and emptying, and due to variations in process and ambient conditions.

Examples for the position of gauge hatches and the construction of reference points are shown in Annex A;

- (c) Still pipes are frequently used as support for the reference point (upper end) and datum plate (lower end). The installation shall be such that the lower tip is fixed close to the bottom and the upper end is guided at the top of the tank. Perforations must be designed to allow free flow of liquid to ensure level and temperature measurement (see ISO 4266-1 and Annex B);
- (d) The shape of the tanks shall be such that the formation of air pockets during filling, or of pockets of liquid after draining is prevented;
- (e) The tanks shall be stable on their foundations; this may be ensured by anchoring or by an adequate period of stabilization, the tank remaining full, so that its base will not vary greatly with time.

6.4 If a calibration table is obligatory, the tanks shall be provided with a data plate bearing an identification of the tank.

The data plate shall be made of a metal which remains practically unchanged under normal conditions of use. The plate shall be fixed on an integral part of the tank, so located that it is readily visible and easily legible, not subject to deterioration, and in such a manner that it cannot be removed without breaking the seals which carry the verification marks.

At least the following information shall be available on the data plate:

- date the tank was built;
- builder;
- nominal capacity;
- max fill height;
- reference height.

Other forms of identification and records of data may be authorized or required by national regulations.

6.5 A dipping datum plate is not required when the tank bottom is sufficiently stable and no risk of sediment forming is present.

7 Metrological characteristics of tanks

The maximum permissible calibration uncertainty applies to the values between the lower limit of accurate capacity and the nominal capacity, shown in the calibration table.

The maximum permissible uncertainty, calculated according to the GUM [1] for $k = 2$, positive or negative, shall be equal to:

- 0.2 % of the indicated volume for vertical cylindrical tanks;
- 0.3 % of the indicated volume for horizontal or tilted cylindrical tanks;
- 0.5 % of the indicated volume for other tanks.

The maximum permissible uncertainties indicated above do not include the uncertainty of the quantity below the datum plate, which is stated in the tank calibration table.

Note: For ISO Standards dealing with tank calibration, see the referent standards listed in Annex C.

8 Metrological controls

8.1 The granting of the “legal” status to a tank and the retention of that status shall include all or part of the following operations:

- initial verification;
- subsequent verification or recalibration in service.

These operations are carried out by or under the control of the national authorities.

8.2 In countries where type approval is mandatory, the approval of design drawings partially replaces type approval which is normally required for ordinary measuring instruments. This approval must be obtained by the manufacturer before he starts construction. For this purpose, he shall submit to the competent authority the design drawings of the tank, showing:

- the general layout;
- the method of fixing the tank on the ground (or underground);
- the position of the valves and of the inlet and outlet pipes, so that the way in which the tank can be completely emptied for the purpose of cleaning and subsequent calibration can be deduced;
- the position and dimensions of deadwoods (positive and negative);
- the details concerning the floating roof or floating cover (if provided) including its mass;
- the details of fitting the liquid level measuring device in the tank;
- the details of fitting the temperature and pressure sensors in the tank;
- the position of the data plate.

If a type approval is not required, a similar procedure shall be applied during initial verification of the tank.

8.3 Initial verification (carried out in two stages)

8.3.1 Examination of the tank in situ

During the in situ examination, the finished construction of the tank shall be checked for conformity to the “as built” drawings. Conformity to all requirements shall be established and documented. The following shall be taken into consideration: the uniformity of construction, any possible permanent deformations, the rigidity of the structure, stability, manholes, access to the gauge hatch, the ability to carry out calibration (if necessary, additional work to facilitate calibration may be required), internal fittings (deadwood), floating roof or floating cover, and attachments for the fitting of the calibration information plate.

The tanks shall be pressure tested, leak proof and cleaned, the results being recorded in a document which shall be presented before calibration starts.

8.3.2 Calibration

The tank calibration shall be carried out in accordance with the applicable ISO Standards, or national standards as required. See 8.5.

8.4 Tank re-calibration and subsequent verification

The national authorities determine the frequency of tank re-calibration, and the requirements.

Tank re-calibration shall also be carried out if deformation of the tank causes a change in its metrological qualities (including reference gauge points, floating roof, and other modifications).

Subsequent verification, when carried out, shall include examination of the construction and of its external appearance. For tanks, used in custody transfer service, the bottom course diameter, bottom course plate thickness, and tank tilt, shall be verified.

8.4.1 Examination of the construction and external appearance of the tank shall be used to ensure that no modifications to the “as build” drawings have occurred. If modifications have occurred, the problem may be solved in situ if it is of minor importance, or the drawings shall be amended and their approval renewed.

8.4.2 Recalibration may be carried out after it has been confirmed that:

- the result of the examination of construction and external appearance is satisfactory;
- the requirements in 6.4 are complied with.

Concerning the calibration itself, the requirements in 8.5 shall also be taken into account.

8.5 Calibration

For the calibration of a tank, one of the following methods shall be used:

- geometric (e.g. optical, strapping);
- volumetric;
- a combination of the two;
- other accepted methods.

The choice of the method or of the procedure is imposed by the nominal capacity of the tank, the shape, the position, the conditions of use, etc.

For more detailed information, see Annex A.

For calibration one of the ISO calibration methods shall be used.

The calibration table shall be made according to applicable ISO Standards:

- ISO 4512 [2];
- ISO 4269 [3];
- ISO series 7507 [4] - [8];
- ISO 12917 [9, 10].

If these Standards cannot be applied, the authority decides on the method which is acceptable.

8.6 Granting of the calibration certificate and application of the verification mark (according to national regulations)

8.6.1 Tanks which comply with all the requirements of this Recommendation shall be accepted for fiscal and custody transfer applications. After calibration, the calibration certificate is issued and the markings on the data plate are completed.

8.6.2 The calibration certificate shall be issued in accordance with the standard used for the calibration.

8.6.3 The legality of the verification is confirmed by applying a verification mark on:

- the calibration certificate;
- the data plate.

8.7 Re-computation of calibration table

In addition to 8.4, the calibration table should be re-computed when encountering:

- a large change in density (specific gravity) of the liquid in the tank since this changes the liquid head correction;
- encrustation.

9 Additional information of the specific types of tanks

9.1 Specific types of tanks

9.1.1 The most common shapes of the tanks are the following:

- cylindrical with vertical or horizontal axis, and with flat, conical, truncated, hemispherical, elliptical or dome-shaped bottom or ends;
- spherical or spheroidal;
- parallelepipedic.

The vertical cylindrical tanks may have a fixed or floating roof (or a floating cover).

9.1.2 The position of the tanks with reference to the ground may be:

- on the ground;
- partially underground;
- underground;
- above ground.

9.1.3 The means used for measuring the levels or volumes (quantities) of liquid contained may be:

- a single graduation mark;
- a measuring device with a graduated scale (with a viewing window or an external gauge tube);
- a graduated rule (dipstick), divided into units of volume or of length, or a graduated tape (dipping tape), divided into units of length, with a dip-weight or sinker (manual measurement);
- an automatic level gauge (automatic measurement).

Tanks, where the quantity of liquid is determined by use of a graduated dipstick or dipping tape, divided into units of length or by use of an automatic level gauge shall be accompanied by a calibration table. See also OIML R 35-1 [15] and OIML R 85-1/2 [16].

9.1.4 The main influence quantities which affect calibration are pressure and temperature. Pressure, including hydrostatic pressure, may alter the apparent volume by distorting the shell; differences from the reference temperature will alter the volumes by expansion or contraction of the shell.

Note: With reference to pressure and temperature, the tanks may be:

- at ambient atmospheric pressure;
- closed, at low pressure (Reid vapor pressure less than 100 kPa);
- closed, at high pressure (Reid vapor pressure more than 100 kPa);
- without heating;
- with heating, but without thermal insulation;
- with heating and thermal insulation;
- with refrigeration and thermal insulation.

Annex A

Practical solutions

(Informative)

A.1 Description of different methods of calibration

A.1.1 The geometric methods consist of direct or indirect measurement of external or internal dimensions of the tank, of the positive and negative deadwood and of the floating roof or floating cover, if provided.

Note: The procedure of internal measurement by means of a tape with a tensioning device is generally not admitted for calibration of tanks containing liquids involved in international trade, except when no better method is applicable (for example, in the case of a thermally insulated tank).

The geometric methods may be used on tanks with a nominal capacity of about 50 m³ and greater, which have a regular geometric shape and show no deformation.

A.1.2 The volumetric method consists in establishing directly the internal capacity, by measuring, by means of a measurement standard, the partial volumes of a non-volatile liquid which are successively delivered into, or withdrawn from the tank. Water is a very suitable non-volatile liquid with the additional advantage of having a small coefficient of expansion.

The volumetric method is generally used for the calibration of the following categories of tanks:

- underground tanks, of any type;
- tanks on the ground or above ground, with a nominal capacity up to 100 m³;
- tanks of a shape not suitable for a geometric method.

A.1.3 The combination method consists in establishing, by means of the geometric method, the volumes corresponding to the shell of the tank and by means of the volumetric method, the volumes corresponding to the bottom of the tank.

This method applies, under the same conditions as the geometric method, to tanks of which the lower part consists of a shape for which the volume cannot be determined with sufficient accuracy, for example due to deadwood, by means of the geometric method.

A.2 General recommendations

A.2.1 The recommended minimum diameter of a perforated or slotted still pipe is 20 cm. Smaller diameter still pipes may be used provided that sufficient space is available for taking manual tank samples with a sample bottle or thief. If smaller diameter still pipes are used, the design and construction of the still pipe should be checked for mechanical rigidity and strength.

A.2.2 The still pipe should be guided at the top of the tank and not rigidly attached.

A.2.3 The lower lip of the still pipe should extend to within 30 cm of the tank bottom.

A.2.4 The still pipe shall have two rows of slots, or two rows of holes (i.e. perforations) located on the opposite sides of the pipe, which start at the lower end of the pipe and continue to above the maximum liquid level. Typical sizes of the slots are 2.5 cm in width and 25 cm in length. Typical diameter of the perforation is 5 cm.

Note 1: In the event a smaller diameter still pipe is retrofitted inside a larger still pipe, the slots or perforations must be designed to allow free flow of liquid to ensure accuracy of the tank measurement (level, sample, and temperature).

Note 2: In certain locations, still pipes without slots (“solid” or “non-perforated”) have been used to comply with local air pollution regulations. Solid still pipes can lead to serious errors in level and temperature measurements and may cause tank overfills. They should not be used for measurement.

Alternatives to solid still pipes which meet air pollution regulations are available.

A.2.5 It is recommended that the still pipe be supported either:

- (a) at the bottom corner of the tank, where the shell plate is welded to the bottom plate, i.e. the stable point to which the datum plate is referred; or
- (b) on the bottom of the tank; or
- (c) by a non-rigid hinged bracket connected to the bottom course of the shell.

A.2.6 The upper end of the still pipe and the sliding guide should be designed to allow vertical expansion of the still pipe when the tank shell bulges or moves vertically. The construction of the pipe and the top guide should not restrict floating roof movement in the vertical direction.

The still pipe may be supported on the bottom of the tank if the tank bottom does not move in relation to the joint where the shell and bottom meet.

For tank construction considerations, the centerline of the still pipe should be located between 450 mm to 800 mm from the shell of the tank.

Note: When a tank is filled, the bottom of the tank may be deflected upwards by the angular deflection of the shell in the area immediately adjacent to the bottom joint. Further from the shell, the bottom is usually deflected downward. The amount of deflection depends on the soil conditions and the foundation design. In most cases, the bulging of the shell ceases to cause bottom movement approximately 450 mm to 600 mm from the shell.

After the tank has been hydrostatically tested, the still pipe should remain vertical.

A.2.7 A water draw valve, a drain, a sump, and a weir (baffle) may be needed in the tank to facilitate water draining. Locks, seals, or other means of positive isolation are recommended.

A.2.8 Proper light at or on the tank should be provided to allow the operator to take measurements at night, if required by operations.

A.2.9 A separate thermometer well, extended from the top of the tank to near the bottom may be desirable for temperature probe installation.

A.2.10 The shape of the tanks shall be such that the formation of air pockets of liquid after draining is prevented.

A.2.11 The gauging platform should be stable such that the effect of the gauger's weight will have negligible effect on the change of the reference gauge height.

A.2.12 If the storage tank is equipped with more than one gauging hatch, an official gauging hatch should be designated and used for opening and closing the gauge during fiscal transfer. The upper reference gauge point should be clearly marked on the hatch.

A.2.13 If side sample taps are installed, they should be positioned to allow tank samples to be taken and for composing an overall representative sample.

A.2.14 The tanks shall be stable on their foundations; this may be ensured by proper soil compressing, anchoring, and/or by an adequate period of stabilization (the tank remaining full, so that its base will not vary greatly with time).

Annex B

Examples of location of gauge hatches and of realization of the reference points (Informative)

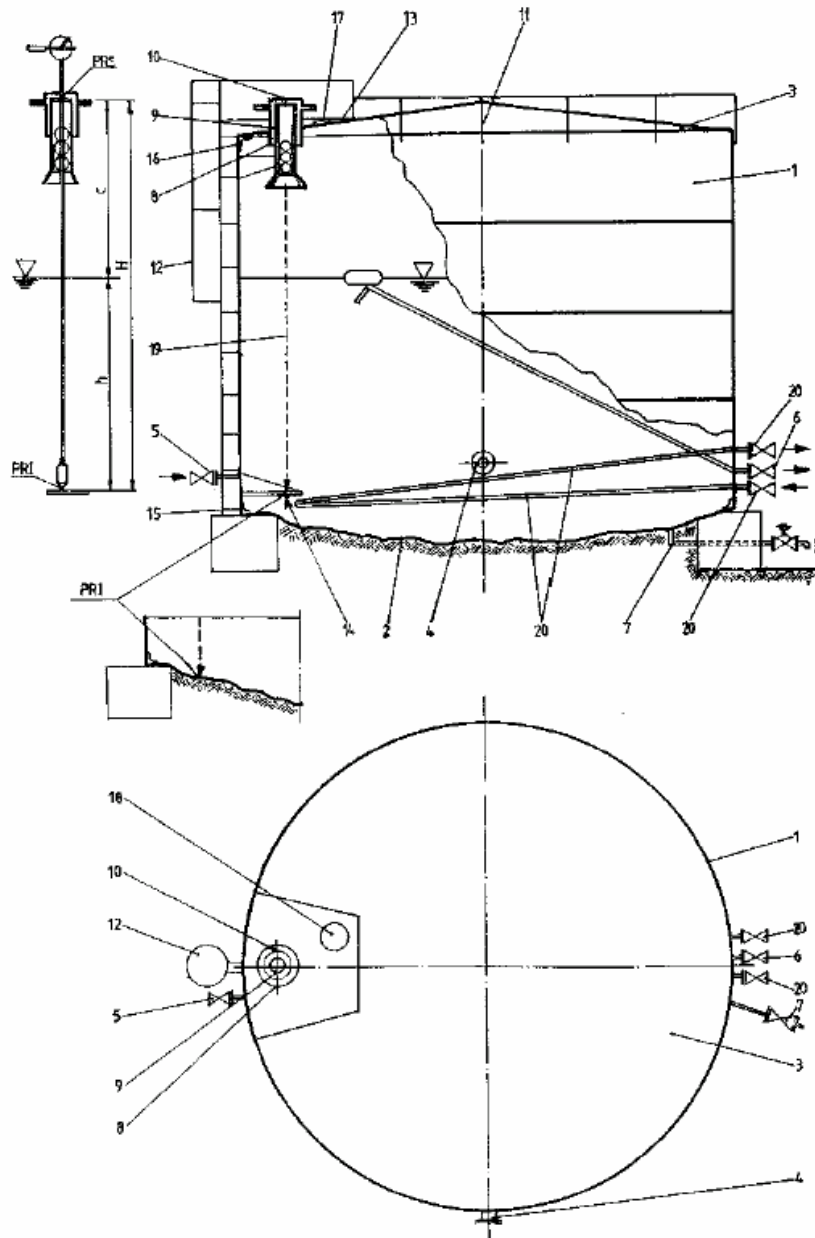

Figure 1 Diagram of a vertical cylindrical tank with fixed roof

1	Shell	10	Lid of the guide pipe	19	Vertical measurement axis
2	Bottom of the tank	11	Handrail	20	Heating coil
3	Roof	12	Access ladder with guard rail	PRS	Upper reference point
4	Manhole	13	Measurement platform	PRI	Dipping datum point
5	Inlet line	14	Dip plate	H	Reference height
6	Outlet line	15	Lower angle-irons	C	Ullage
7	Drain line	16	Upper angle-irons	h	Level of the liquid in the tank
8	Gauge hatch	17	Calibration information plate		
9	Guide pipe	18	Opening		

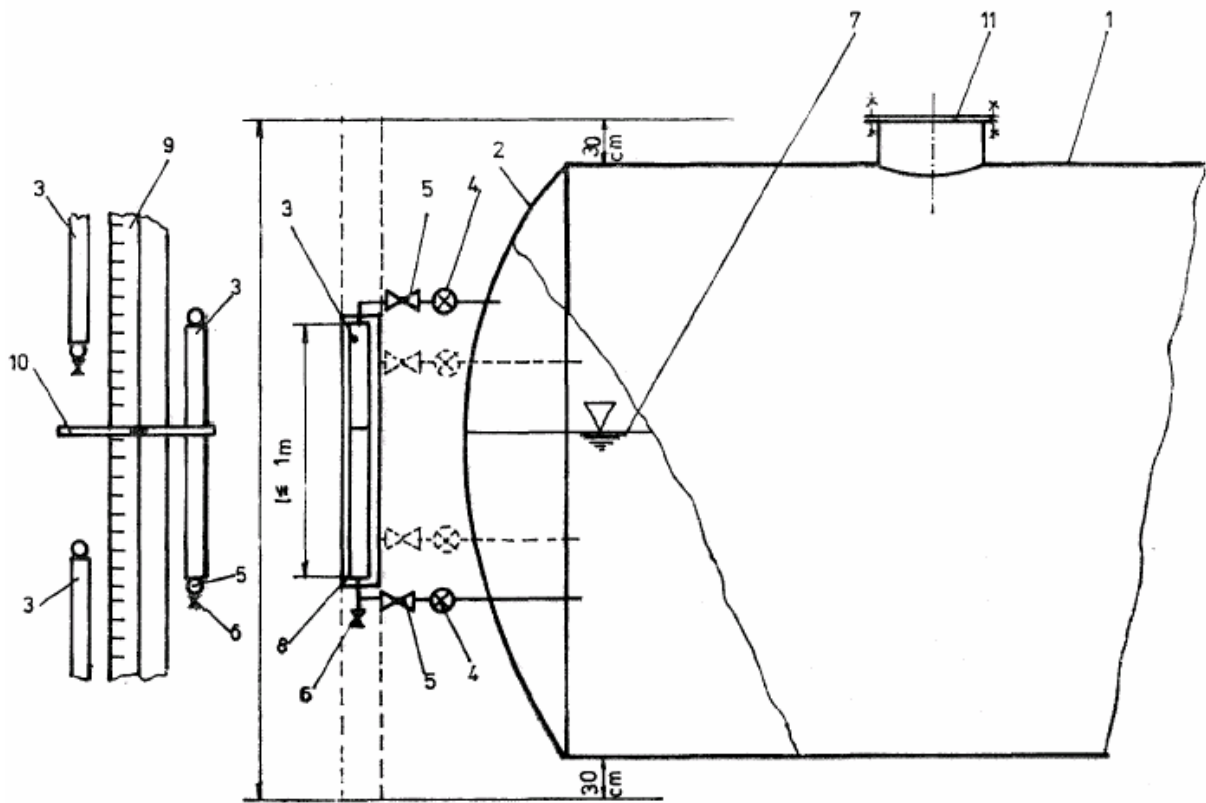

Figure 2 Diagram of a horizontal cylindrical tank with level tube

- | | | | | | |
|---|------------------------|---|---------------------------------|----|-----------------|
| 1 | Cylindrical shell | 5 | Safety shut-off valve | 9 | Graduated scale |
| 2 | End | 6 | Drain valve | 10 | Cursor |
| 3 | Glass tube level gauge | 7 | Level of the liquid in the tank | 11 | Manhole |
| 4 | Isolating valve | 8 | Gauge glass protection | | |

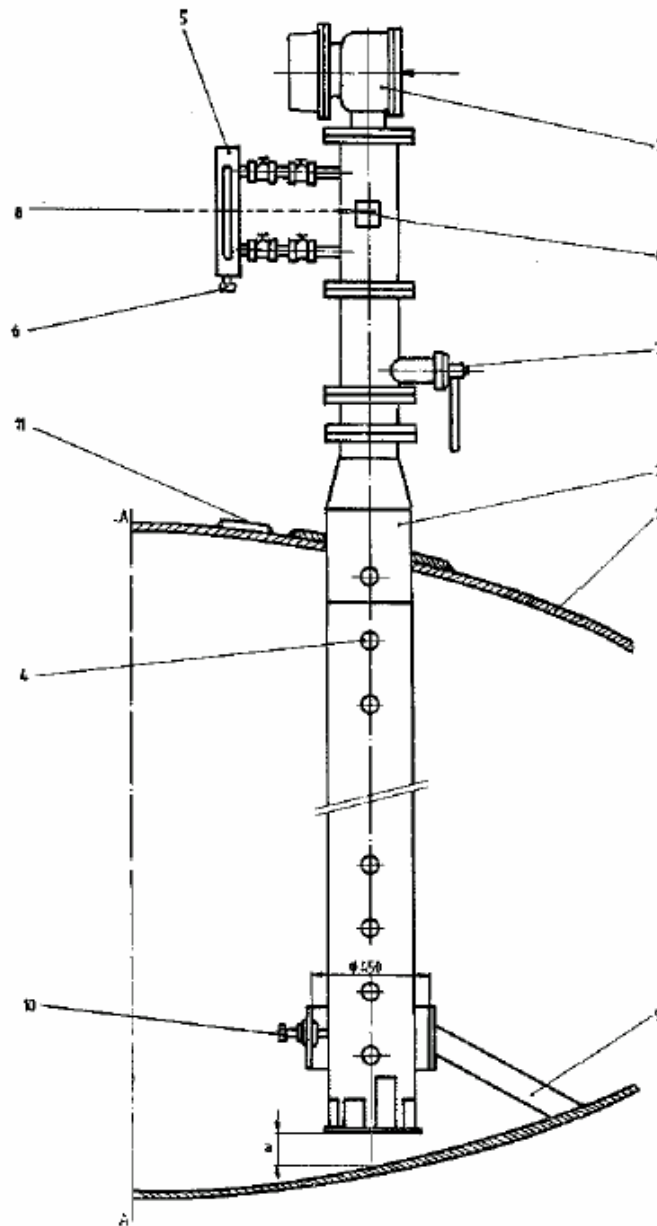

Figure 3 Diagram of a spherical pressurized tank

- 1 Metal wall (sphere)
- 2 Pipe ($\text{Ø}_{\text{int}} = 300 \text{ mm}$) to be adjusted vertically (5 mm tolerance between the vertical determined by plumb bob and three generating lines at 120°)
- 3 Indicating device of the level gauge
- 4 Holes $\text{Ø} 40 \text{ mm}$ at 200 mm pitch
- 5 Glass level indicator, with metal casing
- 6 Drain plug or valve
- 7 Spherical isolating valve
- 8 Mark of reference level (for in-service checking of zero adjustment of the level gauge)
- 9 Three gussets at 120°
- 10 Three bolts for vertical alignment of the guide pipe
- 11 Calibration information plate
- AA Axis of the sphere
- a Minimum dimension compatible with the deformation of the sphere

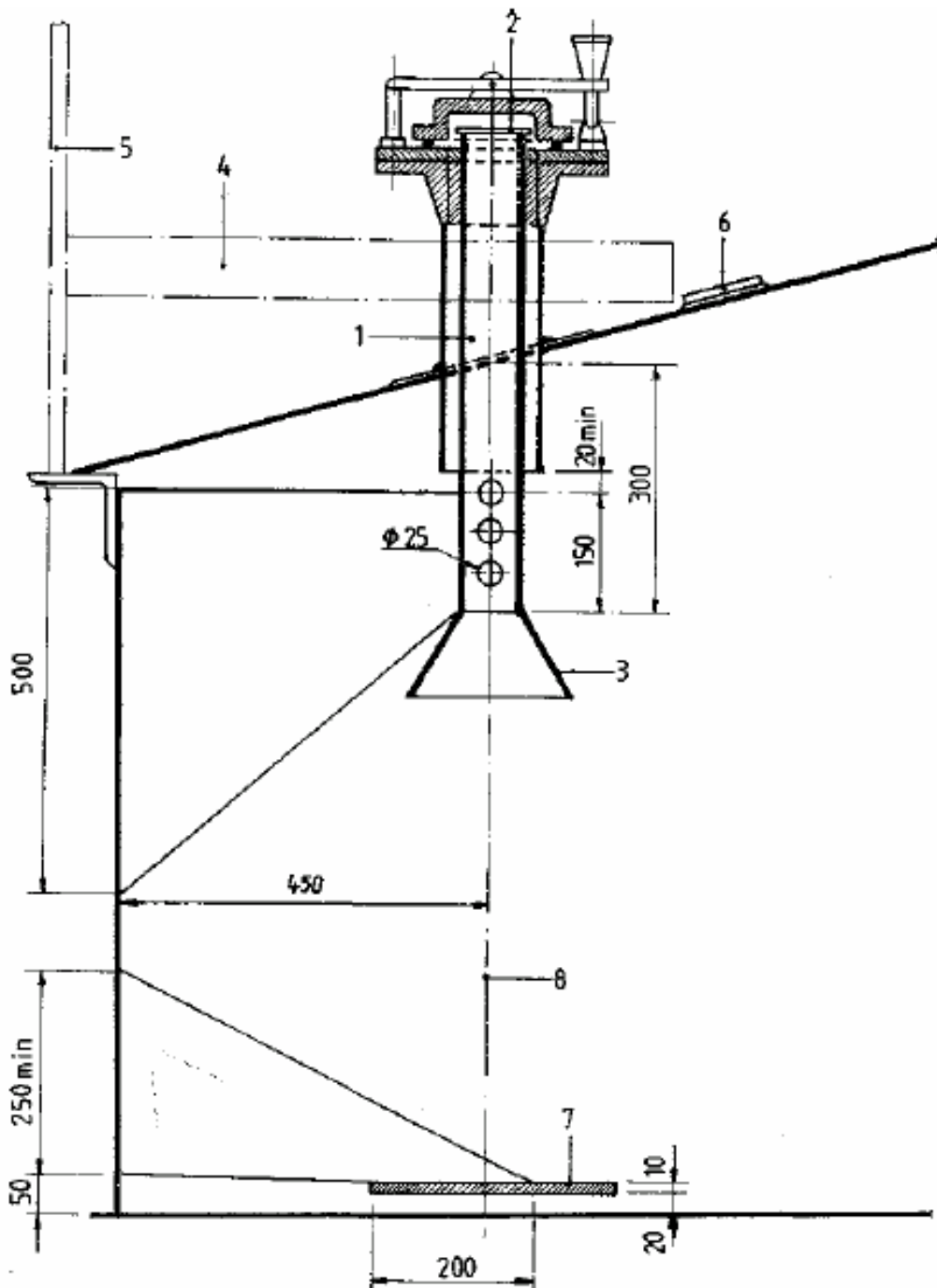

Figure 4 Design details of a guide pipe in a vertical cylindrical tank with fixed roof, of which the deflection when loaded is negligible

- | | | | |
|---|--|---|--|
| 1 | Guide pipe fixed to the upper part of the body by welded gussets | 6 | Calibration information plate |
| 2 | Gauge hatch | 7 | Dip plate (300 mm × 300 mm) fixed to the shell by welded gussets |
| 3 | Funnel | 8 | Vertical measurement axis |
| 4 | Platform | 9 | Lid of guide pipe |
| 5 | Guard-rail | | |

Annex C

Bibliography

Ref.	ISO Standard	Abstract
[1]	OIML G 1:1995 Guide to the expression of uncertainty in measurement (GUM)	This Guide establishes general rules for evaluating and expressing uncertainty in measurement.
[2]	ISO 4512:2000 Petroleum and liquid petroleum products -- Equipment for measurement of liquid levels in storage tanks -- Manual methods	No abstract available.
[3]	ISO 4269:2001 Petroleum and liquid petroleum products -- Tank calibration by liquid measurement -- Incremental method using volumetric meters	No abstract available.
[4]	ISO 7507-1:2003 Petroleum and liquid petroleum products -- Calibration of vertical cylindrical tanks -- Part 1: Strapping method	<p>ISO 7507-1:2003 specifies a method for the calibration of substantially vertical cylindrical tanks by measuring the tank using a strapping tape.</p> <p>This method is known as the strapping method and is suitable for use as a working method, a reference method or a referee method.</p> <p>The operation of strapping, the corrections to be made and the calculations leading to the compilation of the tank capacity table are described.</p> <p>This method does not apply to abnormally deformed, e.g. dented or non-circular, tanks.</p> <p>This method is suitable for tilted tanks with a deviation of up to 3 % from the vertical, provided that a correction for the measured tilt is applied in the calculations.</p>
[5]	ISO 7507-2:2005 Petroleum and liquid petroleum products -- Calibration of vertical cylindrical tanks -- Part 2: Optical-reference-line method	<p>ISO 7507-2:2005 specifies a method for the calibration of tanks above 8 m in diameter with cylindrical courses that are substantially vertical. It provides a method for determining the volumetric quantity contained within a tank at gauged liquid levels.</p> <p>The optical (offset) measurements required to determine the circumferences can be taken internally or externally.</p> <p>The method specified in ISO 7507-2:2005 is suitable for tilted tanks with up to 3 % deviation from the vertical provided that a correction is applied for the measurement tilt, as described in ISO 7507-1.</p> <p>This method is an alternative to other methods such as strapping (ISO 7507-1) and the optical-triangulation method (ISO 7507-3).</p>

[6]	<p>ISO 7507-3:2006 Petroleum and liquid petroleum products -- Calibration of vertical cylindrical tanks -- Part 3: Optical-triangulation method</p>	<p>ISO 7507-3:2006 specifies a calibration procedure for application to tanks above 8 m in diameter with cylindrical courses that are substantially vertical. It provides a method for determining the volumetric quantity contained within a tank at gauged liquid levels. The measurements required to determine the radius are made either internally or externally. The external method is applicable only to tanks that are free of insulation.</p> <p>ISO 7507-3:2006 is suitable for tanks tilted up to a 3 % deviation from the vertical, provided that a correction is applied for the measured tilt as described in ISO 7507-1.</p>
[7]	<p>ISO 7507-4:1995 Petroleum and liquid petroleum products -- Calibration of vertical cylindrical tanks -- Part 4: Internal electro-optical distance-ranging method</p>	<p>Specifies a method for the calibration of vertical cylindrical tanks having diameters greater than 5 m by means of internal measurements using an electro-optical distance-ranging instrument (EODR), and for the subsequent compilation of tank capacity tables. Not applicable to the calibration of abnormally deformed tanks or of noncircular tanks. Applicable to tanks tilted by ≤ 3 % from the vertical, provided a correction is applied for the measured tilt. Applicable to tanks with cone-up or cone-down bottoms, as well as to tanks with flat bottoms.</p>
[8]	<p>ISO 7507-5:2000 Petroleum and liquid petroleum products -- Calibration of vertical cylindrical tanks -- Part 5: External electro-optical distance-ranging method</p>	<p>No abstract available.</p>
[9]	<p>ISO 12917-1:2002 Petroleum and liquid petroleum products -- Calibration of horizontal cylindrical tanks -- Part 1: Manual methods</p>	<p>ISO 12917-1 specifies manual methods for the calibration of nominally horizontal cylindrical tanks, installed at a fixed location. It is applicable to horizontal tanks up to 4 m in diameter and 30 m in length.</p> <p>The methods are applicable to insulated and non-insulated tanks, either when they are above-ground or underground. The methods are applicable to pressurized tanks, and to both knuckle-dish-end and flat-end cylindrical tanks as well as elliptical and spherical head tanks.</p> <p>ISO 12917-1 is applicable to tanks inclined by up to 10 % from the horizontal, provided a correction is applied for the measured tilt.</p>
[10]	<p>ISO 12917-2:2002 Petroleum and liquid petroleum products -- Calibration of horizontal cylindrical tanks -- Part 2: Internal electro-optical distance-ranging method</p>	<p>ISO 12917-2:2002 specifies a method for the calibration of horizontal cylindrical tanks having diameters greater than 2 m by means of internal measurements using an electro-optical distance-ranging instrument, and for the subsequent compilation of tank-capacity tables.</p> <p>This method is known as the internal electro-optical distance-ranging (EODR) method.</p> <p>ISO 12917-2:2002 is applicable to tanks inclined by up to 10 % from the horizontal, provided a correction is applied for the measured tilt.</p>

[11]	<p>ISO 9770:1989 Crude petroleum and petroleum products -- Compressibility factors for hydrocarbons in the range 638 kg/m³ to 1 074 kg/m³</p>	<p>Includes the contents of Manual of Petroleum Measurement Standards, Chapter 11.2.1M published August 1984 by API. The purpose is to correct hydrocarbon volumes metered under pressure to the corresponding volumes at the equilibrium pressure for the metered temperature. Contains compressibility factors related to meter temperature and density of metered material.</p>
[12]	<p>ISO 8973:1997 Liquefied petroleum gases -- Calculation method for density and vapor pressure</p>	<p>No abstract available</p>
[13]	<p>ISO 5024:1999 Petroleum liquids and liquefied petroleum gases -- Measurement -- Standard reference conditions</p>	<p>No abstract available</p>
[14]	<p>ISO 6578:1991 Refrigerated hydrocarbon liquids -- Static measurement -- Calculation procedure</p>	<p>Specifies the calculations to be made to adjust the volume of a liquid from the conditions at measurement to the equivalent volume of liquid or vapor at a standard temperature and pressure, or to the equivalent mass or energy (calorific content). Annexes A to H form an integral part of this standard.</p>
[15]	<p>OIML R 35-1:2007 Material measures of length for general use. Part 1: Metrological and technical requirements</p>	<p>This Recommendation applies to material measures of length for general use, hereinafter called “measures”.</p> <p>It specifies the technical, metrological and administrative conditions which are mandatory for these measures and includes the requirements for digital readouts on the cases of tapes, whether electronic or mechanical.</p>
[16]	<p>OIML R 85-1/2:2008 Automatic level gauges for measuring the level of liquid in stationary storage tanks. Part 1: Metrological and technical requirements. Part 2: Metrological control and tests.</p>	<p>This Recommendation specifies the metrological and technical requirements and test procedures for automatic level gauges for storage tanks. The storage tanks include vertical, cylindrical storage tanks and pressurized storage tanks (spheres, spheroid, bullets). The storage tank may be refrigerated or heated.</p> <p>The metrological purpose of tank level measurements is the application in conjunction with tank calibration tables for the determination of liquid volume received from, delivered to, or contained in stationary storage tanks.</p>